

APPLICATION NOTE 3582

Replacing Crystals and Ceramic Resonators with Silicon Oscillators

Abstract: Silicon oscillators can replace crystal and ceramic-resonator devices in most microcontroller (μC) clock circuits. Besides the advantages of vibration, shock, and EMI resistance, silicon-based timing devices are smaller and easier to use than crystals or ceramic resonators. This application note illustrates how to replace common crystal and ceramic-resonator clock circuits with silicon-oscillator devices.

Introduction

Silicon oscillators are a simple and effective solution for the majority of microcontroller (μC) clock needs. Unlike crystal and ceramic resonator-based oscillators, silicon-based timing devices are relatively insensitive to vibration, shock, and electromagnetic interference (EMI) effects. Silicon oscillators, moreover, do not require careful matching of timing components or board layout.

Apart from any environmental considerations in an application, the selection criteria for a clock source usually depend on four basic parameters: accuracy, supply voltage, size, and noise. Accuracy requirements are typically determined by the communications standards defined for an application. High-speed USB, for example, requires a total clock accuracy of $\pm 0.25\%$. By contrast, systems without external communications may function perfectly well with a clock-source accuracy of 5%, 10%, or even 20%.

Comparison Between Silicon Oscillators and Crystals or Ceramic Resonators

Microcontroller clock supply voltages typically range from 1V to 5.5V. The supply voltages for silicon oscillators typically range from 2.4V to 5.5V.

Clock noise is influenced by a number of sources including amplifier noise, power supply noise, board layout, and the intrinsic noise rejection (or 'Q') properties of the oscillating element. With their high Q values, crystals generally produce the lowest noise oscillator circuits, making them particularly well suited to systems requiring low baseband noise such as audio CODECs.

Silicon oscillators, however, normally occupy the smallest space and do not require additional timing components. Typically, a power-supply bypass capacitor is the only external component required with most silicon oscillators.

Pierce Oscillators

Crystal and ceramic resonator-based oscillators are most often implemented as Pierce oscillators, in which the crystal or resonator serves as a tuned element in the feedback of an inverting amplifier. For stable operation in such a design, the phase-shift compensation and gain control are provided by additional capacitors and resistors. The resistors, moreover, provide the damping needed to prevent overdriving, which can permanently damage the crystal or resonator.

Figure 1 shows two Pierce oscillator examples. Figure 1a is a typical crystal-oscillator circuit using external capacitors and resistors. Figure 1b shows the Pierce oscillator using a three-terminal ceramic resonator which integrates the compensation capacitors. The component values for each of these designs depends on the operating frequency, supply voltage, inverter type, element type (crystal or resonator), and manufacturer.

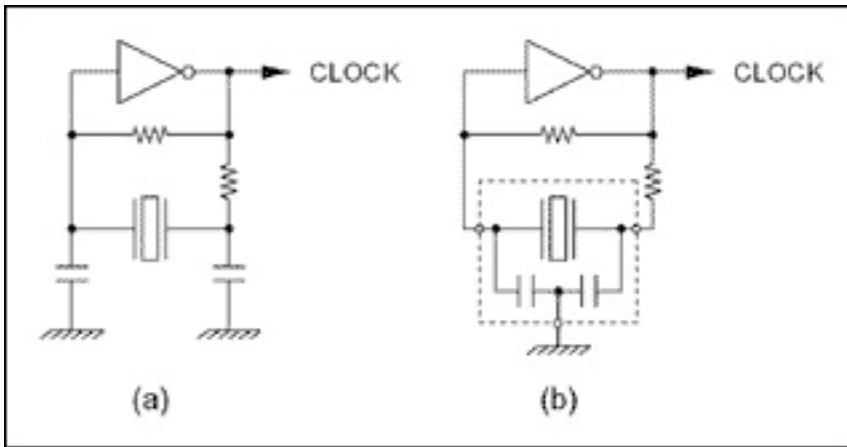

Figure 1. Crystal and three-terminal ceramic resonator Pierce oscillators.

The most common implementation of the Pierce oscillator uses a CMOS inverter gate as the amplifier. Although generally less stable and having higher power consumption than transistor-based oscillators, CMOS inverter-based designs are simple and quite usable over a range of conditions. While both buffered and unbuffered inverters can be used for the amplifier element, unbuffered inverters are preferred because they produce more stable oscillators, albeit with increased power consumption. The unbuffered gate does not have a strong output stage and must, in turn, be buffered by a standard inverter for driving long board traces.

Advantages of Silicon Oscillators

The simplest clock sources are provided by self-contained oscillator devices, such as silicon oscillators. These devices produce a square wave at the specified frequency, which is applied directly to the μC clock input. Silicon oscillators do not rely on a mechanical resonant characteristic to derive the oscillation frequency; they use instead an internal RC time constant. This design makes silicon-based devices relatively immune to external mechanical influences. Also, the lack of exposed high-impedance nodes, such as those found in conventional oscillators, makes silicon oscillators more tolerant of humidity and EMI effects.

Substituting the Silicon Oscillator

When substituting a silicon oscillator for a crystal or resonator device, first discard any components associated with the oscillator circuit. This usually involves the removal of one or two resistors and two capacitors (if these are not included in a resonator package). The oscillator can then be placed at a convenient location with the clock output wired to the μC clock-input (OSC1) pin. Power to the oscillator device should be taken from the same supply as that feeding the μC clock-input circuits.

An example of this design is illustrated in **Figures 2** and **3**, which show oscillator circuits for a MC68HC908 μC . Figure 2 shows the recommended circuit for a three-terminal ceramic resonator. Figure 3 shows the circuit using a silicon oscillator, in this case the MAX7375 which comes in an SC70 package measuring only 2.0mm x 2.1mm, including leads.

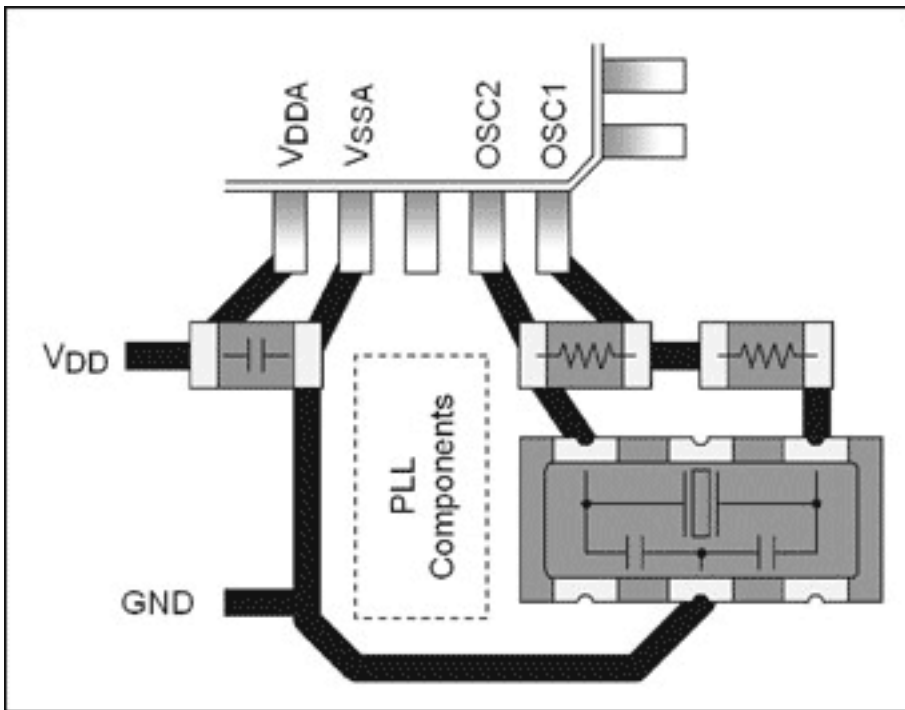

Figure 2. MC68HC908 μ C with a small three-terminal resonator-based oscillator.

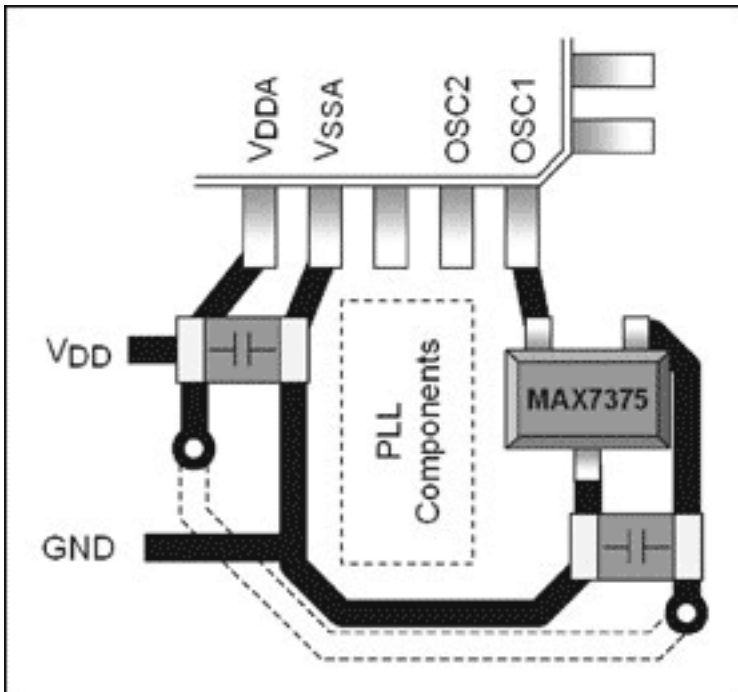

Figure 3. MC68HC908 μ C using the MAX7375 silicon oscillator.

Board placement of silicon oscillators is generally not critical, as these devices output a low-impedance square wave which can be transmitted over reasonable distances without worrying about interference from other signals. Silicon oscillators will also drive multiple clock destinations. Like any high-speed signal, the clock output will produce electromagnetic emissions when driving long trace lengths. These emissions can be minimized by placing a resistor in series with each clock signal and adjacent to the clock generator pin. This approach is illustrated in **Figure 4**, which shows the MAX7375 driving two clock destinations with resistors in line to each.

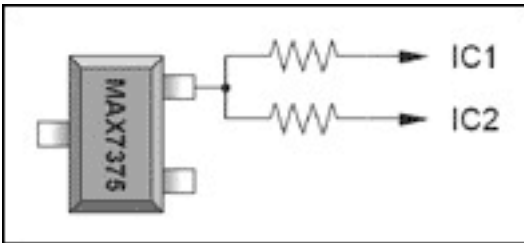

Figure 4. Series resistors minimize EM emissions.

Application Note 3582: www.maxim-ic.com/an3582

More Information

For technical support: www.maxim-ic.com/support

For samples: www.maxim-ic.com/samples

Other questions and comments: www.maxim-ic.com/contact

Automatic Updates

Would you like to be automatically notified when new application notes are published in your areas of interest?

[Sign up for EE-Mail™.](#)

Related Parts

DS1088: [QuickView](#) -- [Full \(PDF\) Data Sheet](#) -- [Free Samples](#)

DS1099: [QuickView](#) -- [Full \(PDF\) Data Sheet](#) -- [Free Samples](#)

MAX7375: [QuickView](#) -- [Full \(PDF\) Data Sheet](#)

MAX7376: [QuickView](#)

MAX7377: [QuickView](#) -- [Full \(PDF\) Data Sheet](#)

MAX7378: [QuickView](#)

MAX7381: [QuickView](#) -- [Full \(PDF\) Data Sheet](#)

MAX7382: [QuickView](#) -- [Full \(PDF\) Data Sheet](#)

MAX7383: [QuickView](#) -- [Full \(PDF\) Data Sheet](#)

MAX7384: [QuickView](#) -- [Full \(PDF\) Data Sheet](#)

MAX7387: [QuickView](#) -- [Full \(PDF\) Data Sheet](#)

MAX7388: [QuickView](#) -- [Full \(PDF\) Data Sheet](#)

MAX7389: [QuickView](#) -- [Full \(PDF\) Data Sheet](#)

MAX7390: [QuickView](#) -- [Full \(PDF\) Data Sheet](#)

MAX7391: [QuickView](#) -- [Full \(PDF\) Data Sheet](#)

MAX7393: [QuickView](#) -- [Full \(PDF\) Data Sheet](#)

MAX7394: [QuickView](#) -- [Full \(PDF\) Data Sheet](#)

AN3582, AN 3582, APP3582, Appnote3582, Appnote 3582

Copyright © by Maxim Integrated Products

Additional legal notices: www.maxim-ic.com/legal