

APPLICATION NOTE 3570

LVDS Multimedia Interface Has Bright Future in Automotive Systems

Abstract: The increasing demand for data communications has produced a variety of new configurations for the data interface, offering different levels of performance appropriate to various applications. Key requirements of this interface development have been faster data rates, high levels of interference immunity, and simple configurations.

This article discusses various multimedia-appropriate features of LVDS including compatibility with low supply voltages, low power consumption, low interference radiation, high interference immunity, and simple cabling and termination.

Low-voltage differential signaling (LVDS) has been tried and tested to be a proven technology in a wide range of applications. LVDS delivers high data rates, along with many other advantages:

- Compatibility with low supply voltages
- Low power consumption
- Low interference radiation
- High interference immunity
- Simple cabling and termination

LVDS operates differentially (**Figure 1**), and the common-mode rejection associated with that mode of operation provides high levels of immunity to interference. Due to a high signal-noise ratio, the signal amplitude can be reduced to nearly 100mV (**Figure 2**), allowing very fast data rates. Low signal amplitudes also reduce power consumption. These advantages substantially outweigh the main disadvantage of LVDS—that two wires are required for each channel of signal transmission.

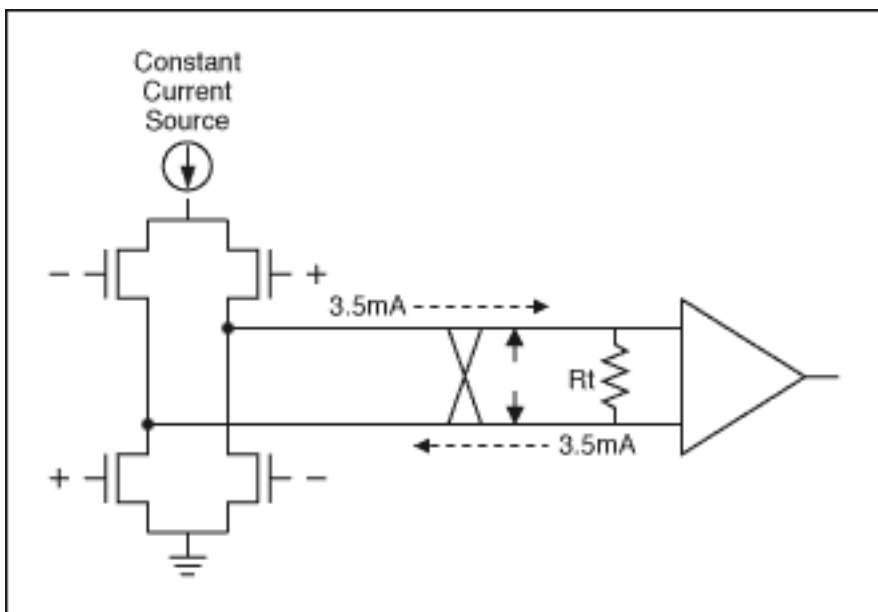

Figure 1. A basic LVDS transmitter-receiver structure.

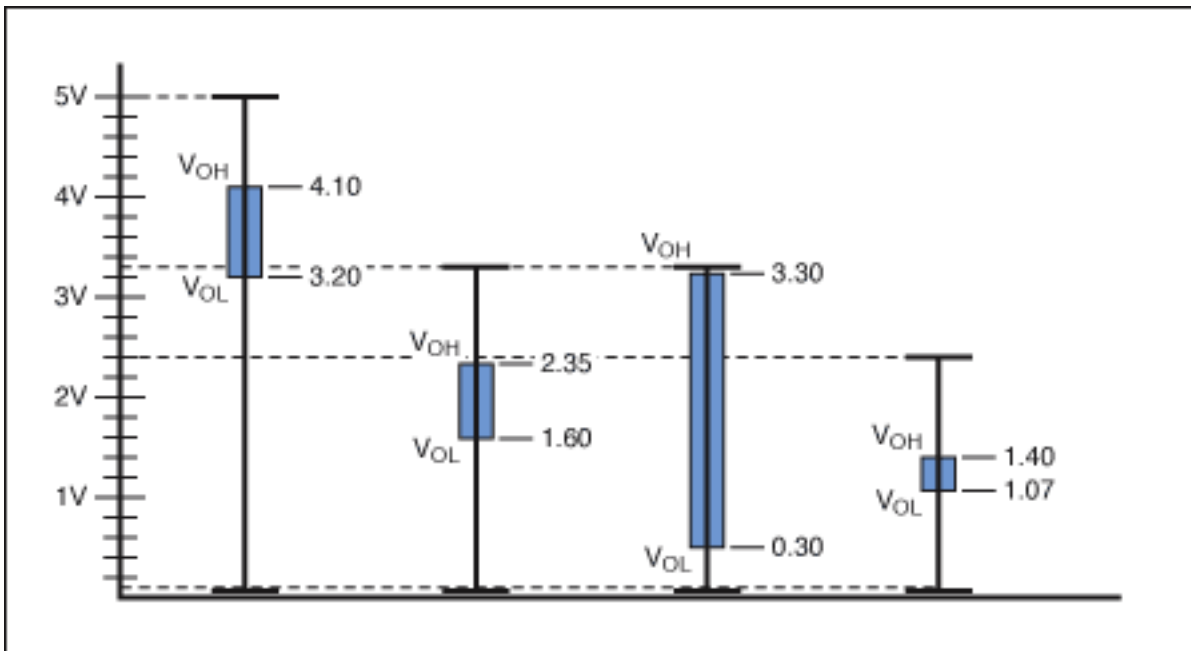

Figure 2. LVDS signal strength and amplitude.

With the integration of more electronic safety and convenience subsystems in automobiles, the automotive industry has seen a huge increase in the demand for faster data rates. This capability is particularly needed in video-display systems for driver support (electric rear and wing mirrors, navigation systems, park-distance control systems, second sight display, heads-up display) and also for entertainment (television and DVD players), which requires high data rates to enable image transmission. LVDS performs extremely well in such applications (**Figure 3**).

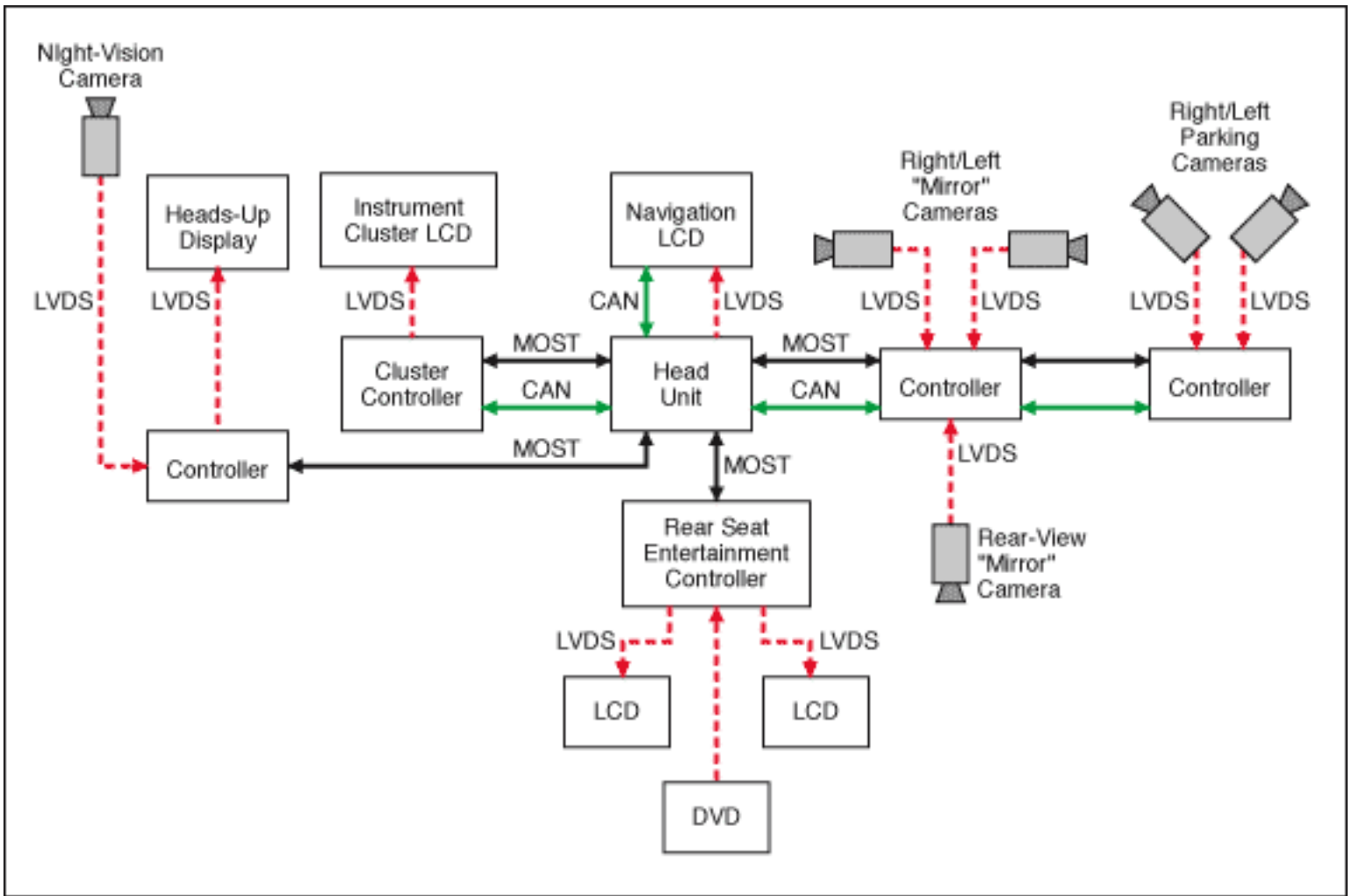

Figure 3. Typical LVDS connections in an automobile.

LVDS is well suited for automotive use. The numerous sources of electromagnetic radiation in automobiles make interference immunity essential, and the low levels of radiation from LVDS lines themselves cause practically no interference. Wiring requirements are minimized by the simple resistor connections of an LVDS system and its simple wiring (twisted copper cable). LVDS is compatible with various bus topologies:

- Point-to-point (one transmitter, one receiver)
- Multidrop (one transmitter, several receivers)
- Multipoint (several transmitters, several receivers)

One area proven to be problematic in cars is the ground offset present at various points on the car body, which can amount to several volts of potential difference. In a DC-coupled interface, such potential differences can quickly disrupt the transmission of data. This problem can be solved by decoupling the signal transmissions using capacitors, with the assumption that data transmissions will not charge these capacitors in one direction for an extended time.

Such charging can occur if, for example, a long series of "ones" is transmitted. ICs, such as the MAX9213/ MAX9214 (**Figure 4**), avoid this problem with the technique of DC balancing, in which the IC monitors data passing through it. When the IC notes an overly long series of ones or zeroes, it inverts the data before transmission. Because the transmitter constantly informs the receiver whether the data stream is normal or inverted, the receiver easily recreates the original data by selective inversion. This elimination of long strings of ones and zeroes minimizes charging of the capacitances, which in turn eliminates the ground-offset problem.

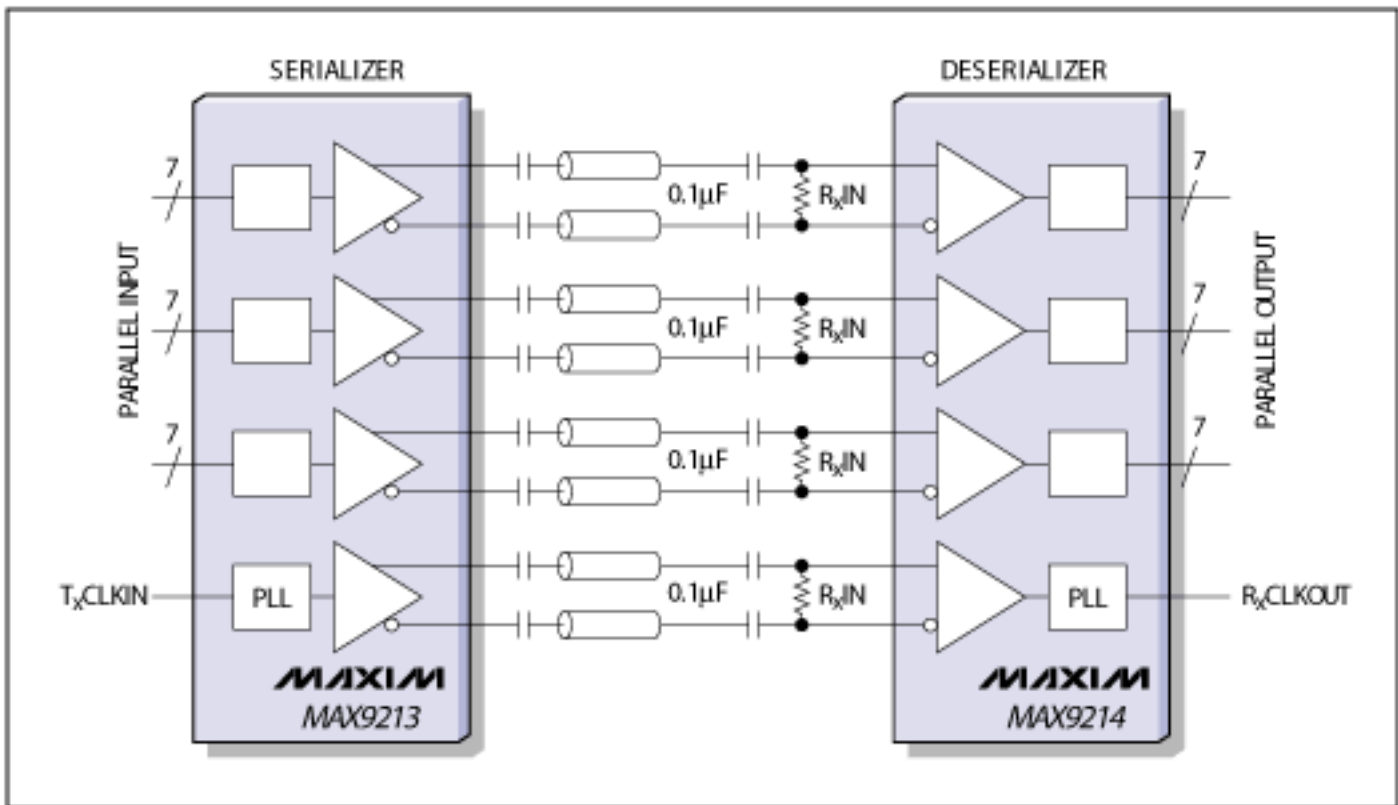

Figure 4. These two ICs combine the functions of transmitter-receiver and serializer-deserializer.

Figure 3 reveals another potential problem. The large number of connections implies a large number of twisted copper cables but, in general, the cable tree (wiring harness) of an automobile is already full. Given, however, that all the connections do not require exceptionally high data rates, Maxim has developed devices (such as the MAX9217/MAX9218 shown in **Figure 5**) that deliver up to 700Mbps using only a single twisted-pair copper wire. That capability ensures that you can connect a display of 480 x 800 resolution without difficulty.

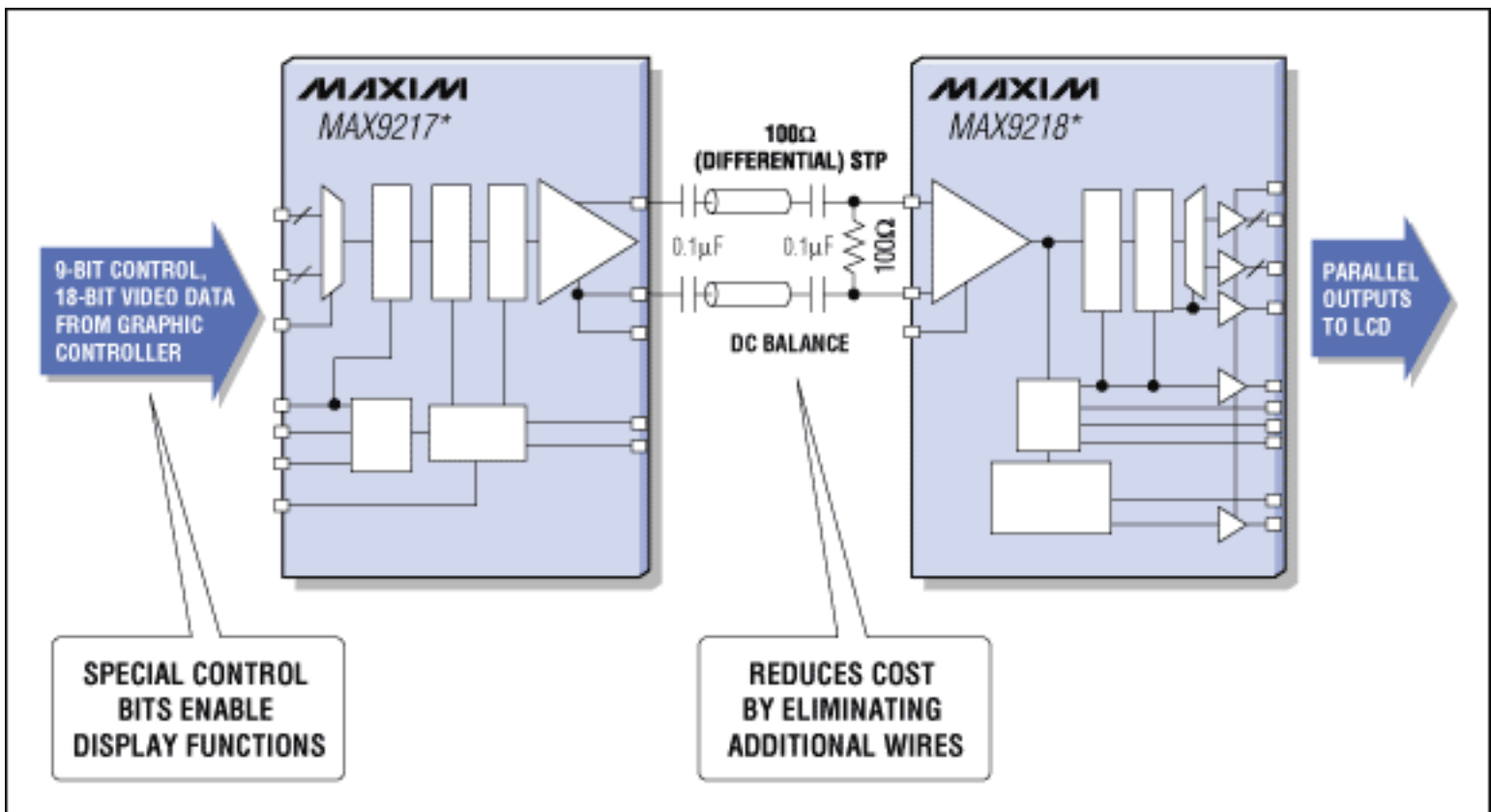

Figure 5. Functional diagram of an AC-coupled serializer and deserializer.

To further improve the already low susceptibility to radiation interference provided by Maxim ICs, these ICs incorporate additional measures to improve electromagnetic compatibility: All switching operations during the display of parallel data are scaled to the clock frequency, which can be adjusted from 3MHz to 35MHz. (Using the lowest allowable clock for a given application minimizes EMI emissions.) Other measures, which minimize EMI by reducing the amount of switching caused by the data stream itself, include special data coding and a common-mode filter on the serial output. An optical interface could improve the EMI values, but that approach has other disadvantages and is far more expensive.

LVDS components must exhibit a high degree of ESD stability, particularly at the input and output pins (a requirement common in the automotive industry). As a consequence, those pins are specified for ESD protection by the IEC 61000-4-2 as $\pm 15\text{kV}$ Air and $\pm 8\text{kV}$ Contact, or by the ISO 10605 as $\pm 25\text{kV}$ Air and $\pm 8\text{kV}$ Contact.

Considering all the capabilities mentioned above, the LVDS interface is an excellent choice for connecting on-board systems in automobiles, today and in the future. For this purpose, the results obtained with first-generation LVDS products, and the experience gained in their application, have led to the development of increasingly sophisticated ICs from Maxim. Within the next few years, these ICs will undoubtedly help the LVDS interface to become an important automotive bus-system.

Application Note 3570: www.maxim-ic.com/an3570

More Information

For technical support: www.maxim-ic.com/support

For samples: www.maxim-ic.com/samples

Other questions and comments: www.maxim-ic.com/contact

Automatic Updates

Would you like to be automatically notified when new application notes are published in your areas of interest?

[Sign up for EE-Mail™.](#)

Related Parts

MAX9213: [QuickView](#) -- [Full \(PDF\) Data Sheet](#) -- [Free Samples](#)

MAX9217: [QuickView](#) -- [Full \(PDF\) Data Sheet](#) -- [Free Samples](#)

AN3570, AN 3570, APP3570, Appnote3570, Appnote 3570

Copyright © by Maxim Integrated Products

Additional legal notices: www.maxim-ic.com/legal