

APPLICATION NOTE 3567

Monitoring and Sequencing Supply Voltages in High-Reliability Systems

Abstract: This application note focuses on the need to properly monitor and sequence voltages in high-reliability systems. It presents key selection criteria for choosing a supervisor and explains the need for a power-on reset (POR) circuit, multivoltage monitoring, and margining. System-management circuits are discussed.

Introduction

For most electronic systems, monitoring system voltages with a power-on reset (POR) ensures proper initialization at power-up. Detecting brownout conditions with a POR, moreover, minimizes possible code-execution problems that can corrupt memory or cause the system to execute improperly. To improve reliability in high-end systems, it is often necessary to sequence a system's power supplies in the correct order to prevent the system's microcontrollers, microprocessors, DSPs, or ASICs from latching up—a problem that can cause damage or long-term reliability issues. In most cases, one or more microprocessor supervisor ICs can readily perform these sequencing and monitoring functions.

Monitoring Voltages with Detectors and Power-On Resets

A simple way to monitor a system supply voltage is with a voltage detector, an IC that combines a comparator and an internal reference. When the supply voltage falls below the voltage detector's threshold, its output asserts to notify the system's microcontroller of an impending power failure. This warning gives the microcontroller an opportunity to back up its memory, turn on or off power supplies, and shut down the system in a controlled manner.

When a voltage detector changes states during power-up or down, its output asserts after a short propagation delay. This is fine for a power-fail warning. In most cases, however, a microcontroller's reset input requires a longer delay, called a reset timeout; during power-up, the system clocks and power supplies must stabilize and the processor's registers must initialize before releasing the microcontroller from its reset state. A power-on reset (POR), a form of microprocessor supervisor IC, provides this reset timeout so the system can fully initialize before allowing the microcontroller to operate. Also, if the supply voltage temporarily falls below the POR's threshold after power-up, this same delay applies when the supply voltage returns above the POR threshold. Power-on resets are available with several different, fixed timeout periods and threshold voltages. Some PORs provide capacitor-adjustable timeout periods.

Monitoring Multivoltage Systems

Most systems monitor the 3.3V I/O logic supply. For systems requiring higher reliability, it may be necessary to monitor additional supplies, such as those that power cores and memory. Numerous multivoltage microprocessor supervisors can perform this task, but the specific requirements of a given system will quickly reduce the number of designer's choices.

Most supervisors monitor standard voltages such as 5V, 3.3V, 2.5V, and 1.8V. It is, however, often necessary to monitor additional voltages because various components (e.g., memories, PLDs, ASICs) have unique power-supply requirements. As a result, you must decide whether to use a fixed-threshold device, which requires no external resistors, or a more flexible adjustable-threshold device that accommodates changes as needed but requires external resistors. A device with a combination of fixed and adjustable thresholds can provide the best solution. When selecting a device, it is important to choose one with a reference whose voltage is low enough to monitor the system's lowest voltage. When working with 0.8V, 0.9V, and 1V supplies, for example, a device with a standard 1.2V reference would not work.

The number of supply voltages present in high-reliability systems increased in recent years; ten or more voltages are now common. When monitoring a large number of voltages, you can end up using several supervisor devices. Multivoltage supervisors with open-drain outputs are often advantageous in these situations because their outputs can be OR'd together to provide a single output. **Figure 1** shows an example of two MAX6710s connected to provide one reset signal while monitoring eight voltages.

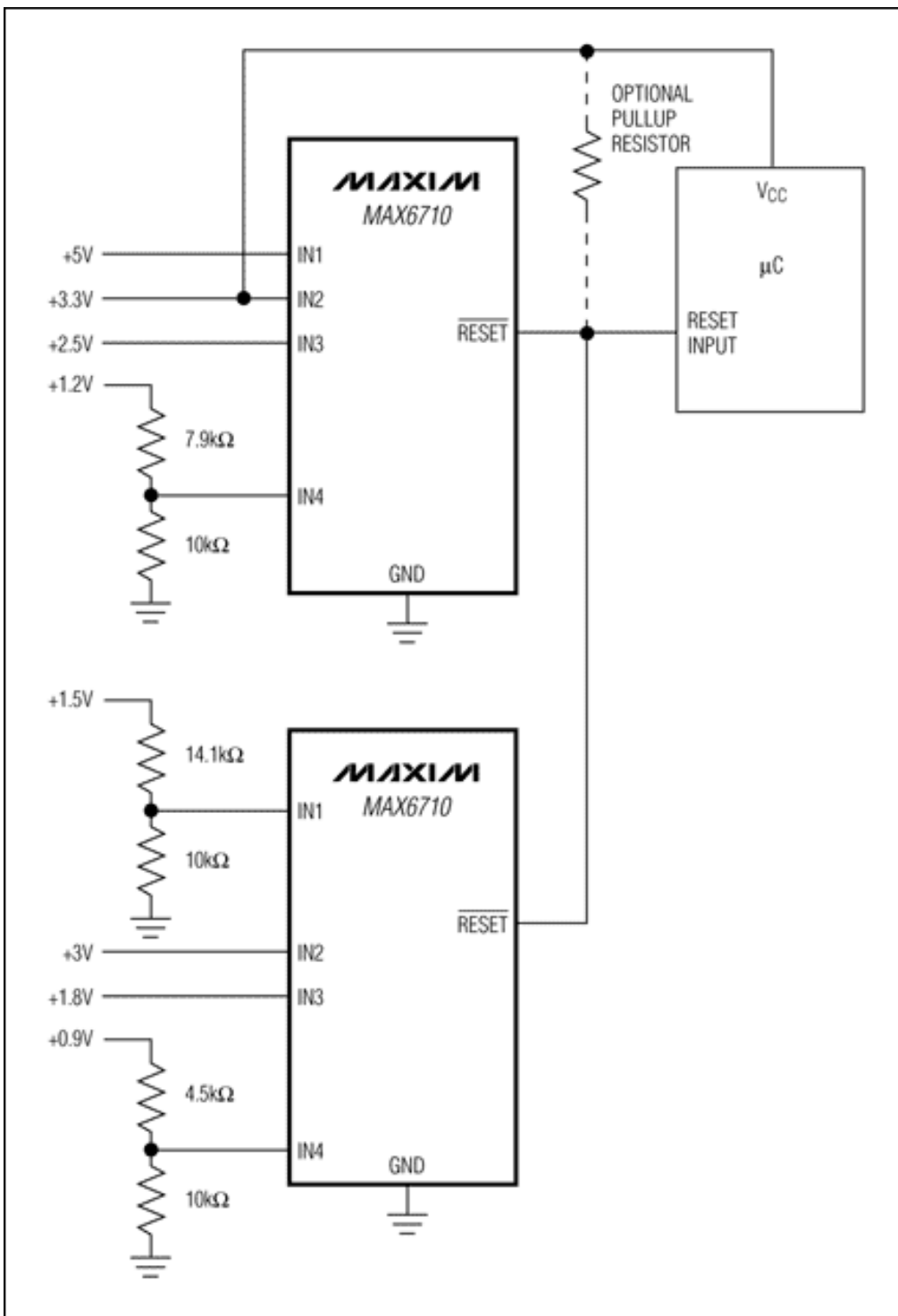

Figure 1. Two multivoltage supervisors with open-drain outputs monitor eight voltages and provide a single reset output.

Overvoltage Protection Circuits

Some power supplies must be monitored for undervoltage and overvoltage conditions. Overvoltage monitoring has become necessary in many systems to prevent damage to expensive processors and ASICs. Two types of overvoltage protection circuits are commonly used. A window detector, which monitors both overvoltage and undervoltage conditions, can be constructed with two voltage detectors and a reference. Alternatively, you can use a dedicated window-detector IC, such as the MAX6754. A second type of voltage-protection circuit includes an external p-channel MOSFET that shuts off a supply if the supply voltage exceeds a specified level. See **Figure 2**.

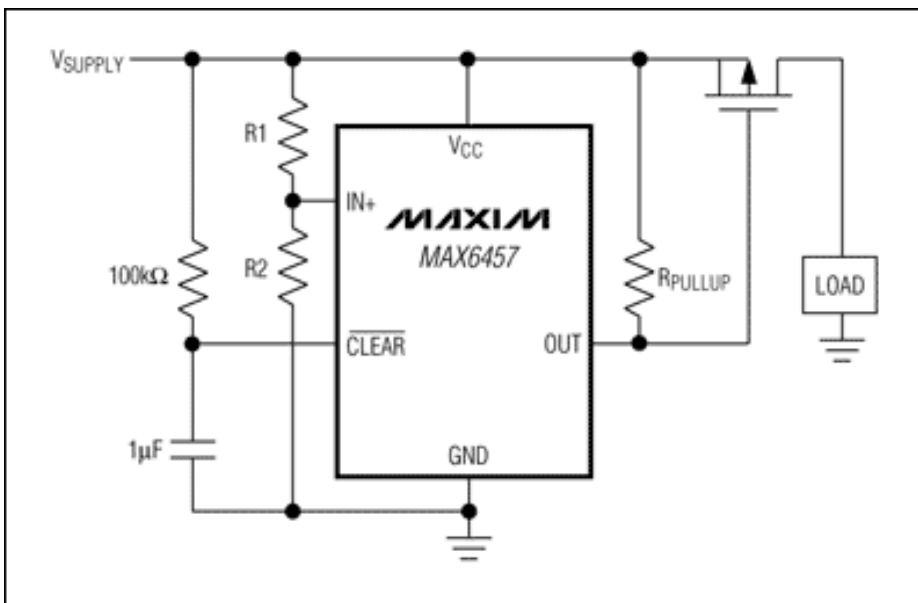

Figure 2. When this supervisory circuit detects an overvoltage condition, the p-channel MOSFET disconnects the supply.

Sequencing Power Supplies

You can conveniently sequence power by using the enable or shutdown pins of the DC-DC power regulators. Under this "daisy-chaining" scheme, when a power supply first comes up, it asserts its Power OK (POK) signal (if it has one) to notify other circuitry that its voltage is within tolerance. The POK output connects to the shutdown or enable pin of the second regulator, and turns on that regulator when it goes active. **Figure 3** diagrams this approach. For situations where a longer delay is needed, some regulators include a POR. This latter arrangement allows a longer time delay before turning on the next power supply in the sequence.

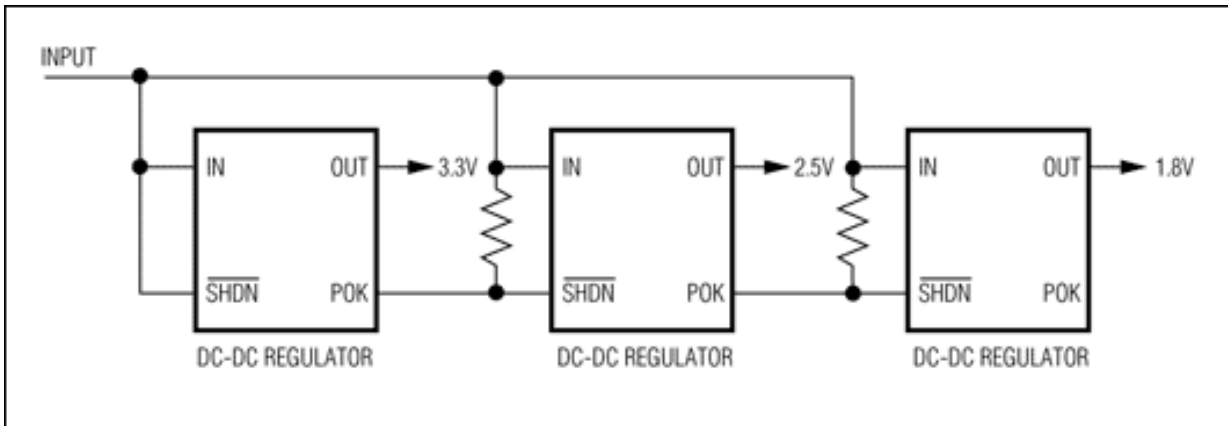

Figure 3. A power supply with a POK output provides a convenient way to sequence other supplies.

When a POK signal is not available, you can monitor a power supply's output with a voltage detector or a POR. Simply connect the detector or POR output to the second supply's shutdown or enable input. The second supply then turns on when the monitored voltage exceeds a specific threshold. When used with noisy power supplies, a voltage detector can turn a regulator on and off unnecessarily several times, especially if the monitored voltage level is near its trip threshold. In these situations, a POR circuit can minimize this effect—a benefit of the POR's timeout period. When the monitored voltage falls below the supervisor's threshold, the POR's output asserts and remains asserted for at least the minimum reset timeout period after the monitored voltage returns above the threshold. The voltage must be above the reset threshold continuously during the timeout period for the supervisor to deassert, thus preventing the power supply from cycling repeatedly. Using a POR to generate a signal for the shutdown or enable pin also allows you to control the turn-on time; PORs have reset timeouts that range from a few microseconds to more than one second. Also, capacitor-adjustable PORs allow you to change the timeout period of a given device.

A POR circuit also lets you control other power-up sequencing situations. Suppose, for instance, that in a system with three power supplies you want the first two supplies to be valid before the third supply is activated. If a single regulator without a POK output generates the first two supplies, you can use a dual-voltage POR to monitor its two voltages. This POR's output then controls the sequencing of the third supply by feeding its enable or shutdown pin. To sequence larger numbers of supplies, you can use multivoltage devices. A quad voltage detector, for example, is suitable for sequencing four voltages. Furthermore, devices with multiple reset outputs with different delays can be used to sequence multiple supplies.

Turning On Pass Elements

When using a "silver box" or "brick" power supply, turning on and off each voltage in a controlled order is not always possible without additional circuitry. These power supplies provide standard voltages, such as 5V, 3.3V, 2.5V, and 1.8V, which are often distributed throughout a system. A "brick" can provide, for example, a 3.3V logic supply and a 1.8V core supply to two different ICs. In some applications, these ICs will require different power sequencing; one device needs the core supply to rise first while the second device requires the I/O supply to rise first.

One way to sequence supplies in this situation is to switch power through an external pass element. **Figure 4** shows a voltage detector connected to the gate of a MOSFET, which turns on and off V_{CC1} . An n-channel MOSFET is appropriate for this application when there is a higher voltage available to provide a gate-to-source voltage large enough to fully enhance the MOSFET. A problem can occur, however, during this circuit's power-up if V_{CC2} is present prior to V_{CC1} reaching a level sufficiently high to turn on the voltage detector's output. In this situation, V_{CC2} will enhance the MOSFET (i.e., it will be on) until V_{CC1} rises sufficiently for the voltage detector's output to assert a low.

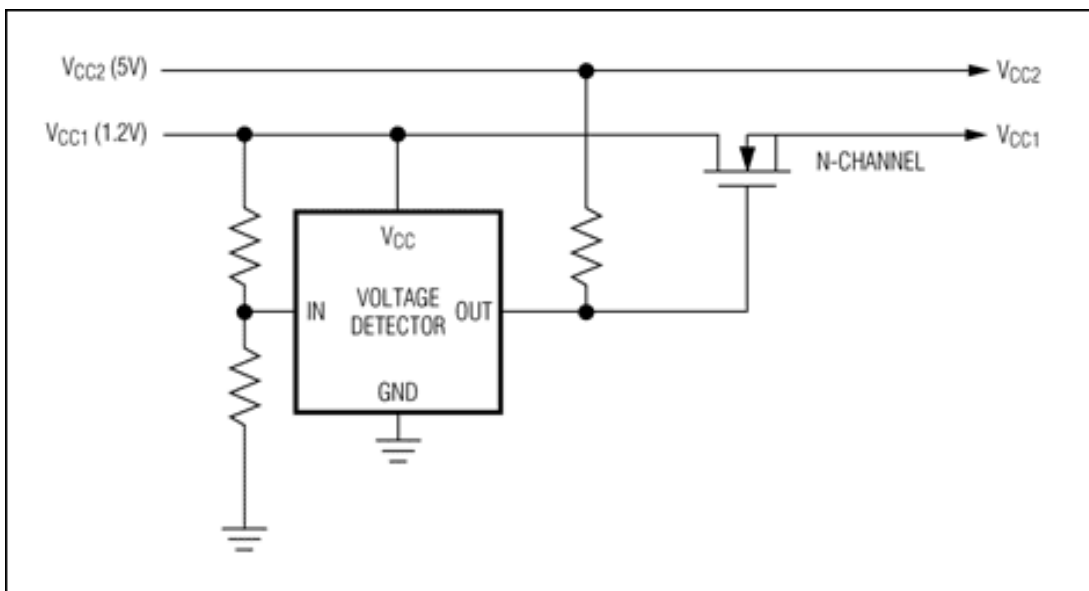

Figure 4. If a higher voltage is available, a voltage detector can sequence a low voltage by turning on an n-channel MOSFET.

This same type of circuit can be realized with a voltage detector and a p-channel MOSFET without needing a second, higher voltage. This circuit is not, however, suitable for low-voltage supplies and the higher on-resistance of a p-channel MOSFET makes it impractical for high-power applications.

An easier and more reliable approach to power-sequencing multiple supplies uses a device such as the MAX6819 to perform both the monitoring and the sequencing functions (see **Figure 5**). This type of IC monitors the first voltage with a reset circuit to determine whether it is within specification; when the voltage is within specification, the IC uses its MOSFET driver to turn on the MOSFET. An internal charge pump adds a fixed voltage to the secondary supply and the resulting voltage is applied to the gate of the MOSFET, which helps ensure that the gate-to-source voltage is sufficiently high to fully enhance the MOSFET.

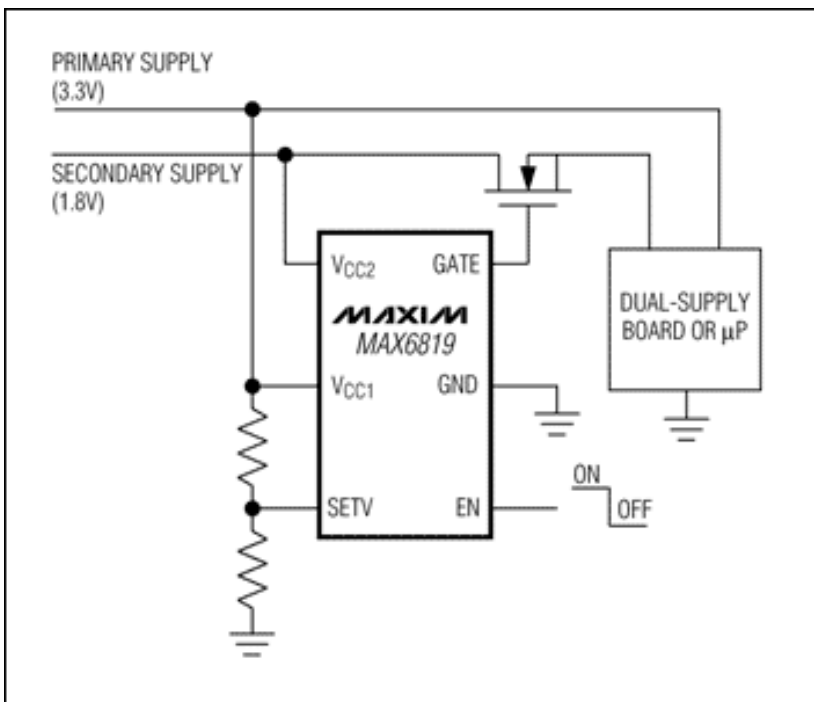

Figure 5. After the primary supply has powered up, the MAX6819 turns on the secondary supply. The MAX6819's on-board charge pump enhances the MOSFET to minimize its on-resistance.

The Margining Function

During the manufacturing phase of many types of telecommunication, networking, storage, and server equipment, a process called "margining" is often used to assess the robustness and future reliability of these systems. Margining involves an evaluation of the system (or processor), which is performed by deviating the power supplies from their nominal levels. To change those levels, typically a DC-DC converter power supply is adjusted by altering its feedback loop with a digital pot or a current DAC. **Figure 6** depicts two of the many ways of margining a supply. Other common methods include programming the supply's output through a digital interface or trimming the power supply. Different degrees of margining control include "pass/fail" approaches where you increase or decrease all power supplies to some level (e.g., $\pm 5\%$ or $\pm 10\%$). Margining control can take a finer-adjustment approach in which you increment or decrement the supplies in smaller steps (e.g., 10mV or 100mV). This latter approach allows you to evaluate the system performance in greater detail.

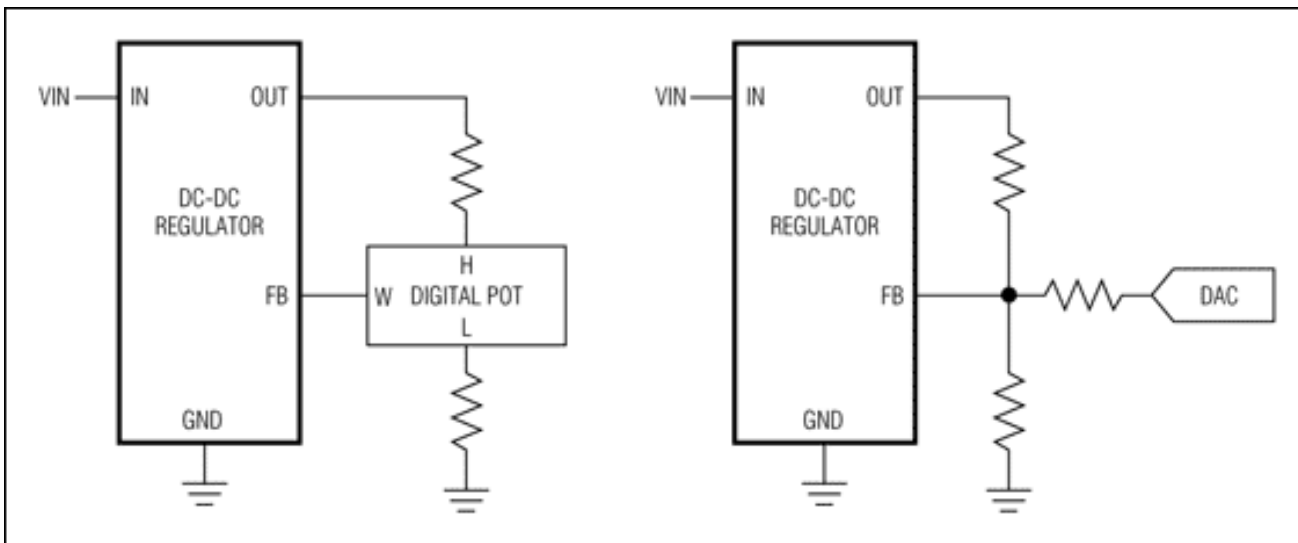

Figure 6. Two simple techniques for performing voltage margining include adding a digital pot or a current DAC to a DC-DC converter's feedback loop.

An ADC can be used to measure these values more accurately. It can be tempting to use the ADC contained within a microcontroller for this function. However, when the supplies powering the microcontroller drop below specification, its internal reference can be out of tolerance, thus affecting the ADC's accuracy. Also, it is necessary during margining to disconnect or disable the reset output so that the system can continue to operate. Otherwise, the system will reset, making it impossible to discover the supply-voltage levels at which the system fails. Performing these margining functions can be quite tedious when working with large systems.

Combining Monitoring, Sequencing, and Margining Within a Single Device

Many processors require only two voltages, one to power the core and another to power the I/O. Other devices such as DSPs, ASICs, network processors, and video processors can require up to five supply voltages. Within a single system, it is not uncommon for supervisory circuits to monitor and sequence more than ten voltages. As the number of supply voltages in these systems continues to increase, the number of ICs needed to monitor, sequence, and margin them also increases. Costs rise and more board space is consumed. When changes to parameters such as a voltage threshold or a reset-timeout period are necessary, a new device may be required. Changing the sequencing order, moreover, becomes quite a difficult task.

One way to reduce the level of circuit complexity is to use a programmable system-management IC that combines the monitoring and sequencing functions. With programmability, these devices make changes easy to handle. These circuits eliminate the need to swap parts in and out of a design during the prototyping and manufacturing stage. For many of these parts, a serial interface allows you to program the internal registers that both configure these devices and set threshold levels and delays; on-board EEPROM stores the contents of those registers.

Figure 7 shows a MAX6870 system-management device set up to monitor and sequence several system supplies. When the +12V bus voltage powers up and exceeds its threshold (stored within the MAX6870), one of the MAX6870 outputs enables the +5V voltage regulator, either immediately or after a delay period (also stored within the MAX6870 memory). After the +5V regulator comes up and its output crosses its corresponding threshold, the +3.3V supply is taken out of shutdown. The remaining supplies then power up in succession under this same scheme, except that the +5V switched supply becomes available when the MAX6870 enhances the n-channel pass element.

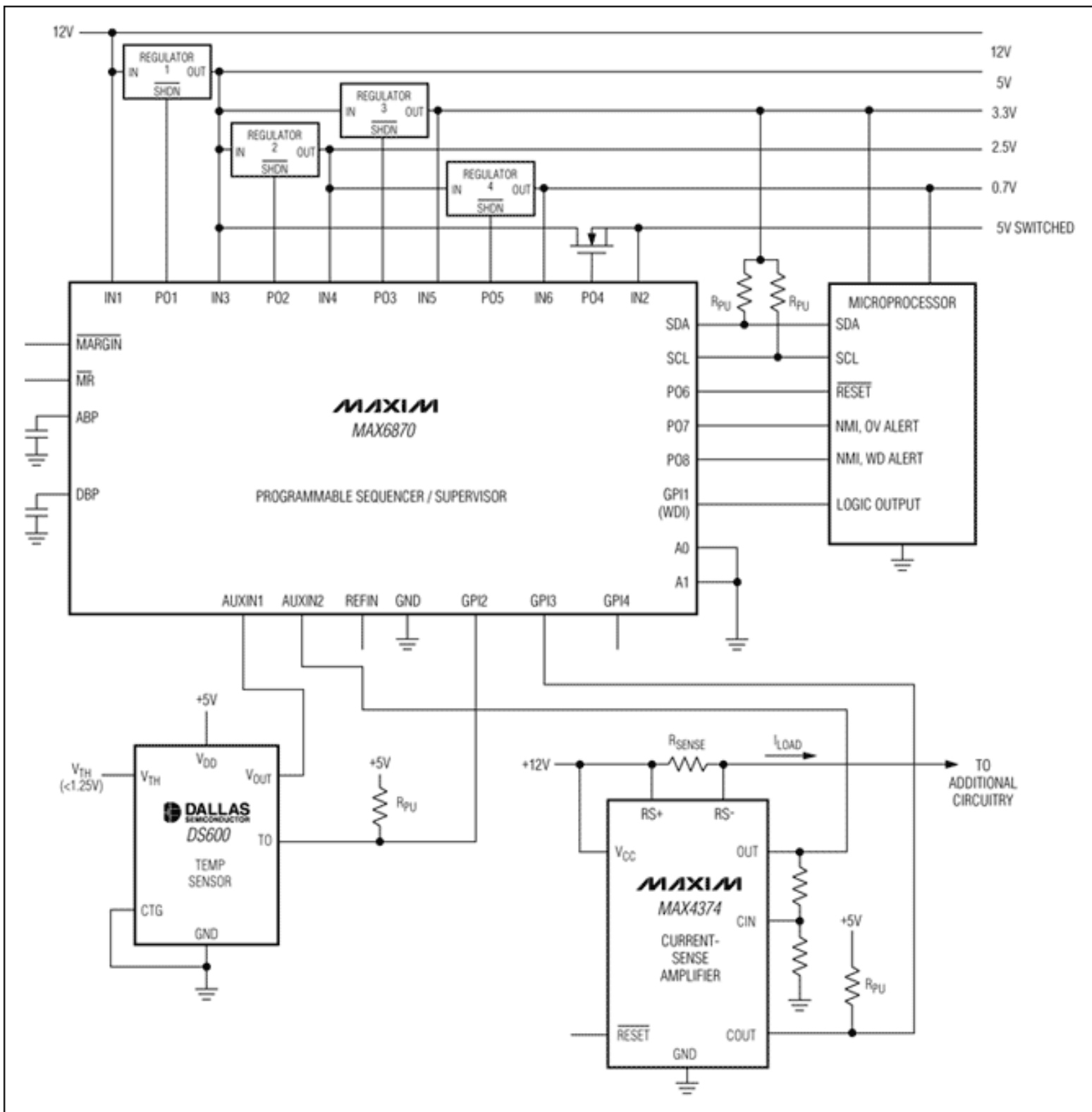

Figure 7. A programmable system-management device provides a flexible means for voltage monitoring and sequencing.

You can usually program this type of system-management device to provide additional supervisory functions such as reset circuits and watchdog timers. These devices can also monitor parameters other than supply voltage through their analog and digital inputs. In the circuit of Figure 7, AUXIN_ (analog inputs) and GPI_ (digital inputs) monitor a temperature reading and a power-supply current-sense reading. The MAX6870 includes a 10-bit ADC that digitizes those readings; the microcontroller monitors the status of those digitized readings. The temperature sensor and the current-sense monitor each include a comparator output that indicates that a fault has occurred (i.e., the temperature or the current exceeded a specific limit). Each comparator output connects to a MAX6870 general-purpose input (GPI). The MAX6870 can be configured to turn off one or more power supplies when these fault conditions occur, thus reducing the load on the +12V supply.

The internal ADC makes it easy to accurately margin a power supply. The voltage at each power supply's output can be read from the ADC registers during the margining process. Also, the margin input can disable the outputs or program them to a known state when the supplies are margined, thus preventing the system from resetting during this procedure.

Conclusion

There are numerous ways to monitor, sequence, and margin voltages in high-end systems. The new generation of system management devices addresses the complexity that system designers face today. New, fully integrated devices provide an alternative to traditional solutions and give more flexibility and function within a single device, thus saving board space, cost, and design time.

Application Note 3567: www.maxim-ic.com/an3567

More Information

For technical support: www.maxim-ic.com/support

For samples: www.maxim-ic.com/samples

Other questions and comments: www.maxim-ic.com/contact

Automatic Updates

Would you like to be automatically notified when new application notes are published in your areas of interest? [Sign up for EE-Mail™](#).

Related Parts

MAX6710: [QuickView](#) -- [Full \(PDF\) Data Sheet](#) -- [Free Samples](#)

MAX6754: [QuickView](#) -- [Full \(PDF\) Data Sheet](#) -- [Free Samples](#)

MAX6819: [QuickView](#) -- [Full \(PDF\) Data Sheet](#) -- [Free Samples](#)

MAX6870: [QuickView](#) -- [Full \(PDF\) Data Sheet](#) -- [Free Samples](#)

AN3567, AN 3567, APP3567, Appnote3567, Appnote 3567

Copyright © by Maxim Integrated Products

Additional legal notices: www.maxim-ic.com/legal