

TEST2.7	TEST2.6	TEST2.5	TEST2.4	TEST2.1	Output
0	1	1	0	X	Rcvr additional 6dB attenuation pad
0	1	1	1	0	Rcvr 20dB monitor mode
0	1	1	1	1	Rcvr 12dB monitor mode
1	0	0	0	1	Bypass equalizer

3. Common Control bits settings (address 0A)

CCR7.2 = 1

Line Interface Synchronization Interface Enable

CCR7.1 = 1

1 Customer will generate a CDI pattern at TTIP & TRING instead of normal data.

CCR7.0 = 1

TTIP & TRING become open drain

Test Register Settings for the DS21x54 & DS21Q44

1. TEST1 (address 15) can be used for output test mode and error counter functionality.

TEST1.7 and TEST1.6 can be used to force all outputs into a logic 1, logic 0 or 3-state.

TEST1.7	TEST1.6	Output
0	0	NORMAL OPERATION
0	1	3-STATE
1	0	LOGIC '0'
1	1	LOGIC '1'

TEST1.4 and TEST1.3 can be used for error counter functionality.

TEST1.4

Sample error counters. (See figure below)

TEST1.3

Set High to Enable Test1.4 to control sampling of error counters

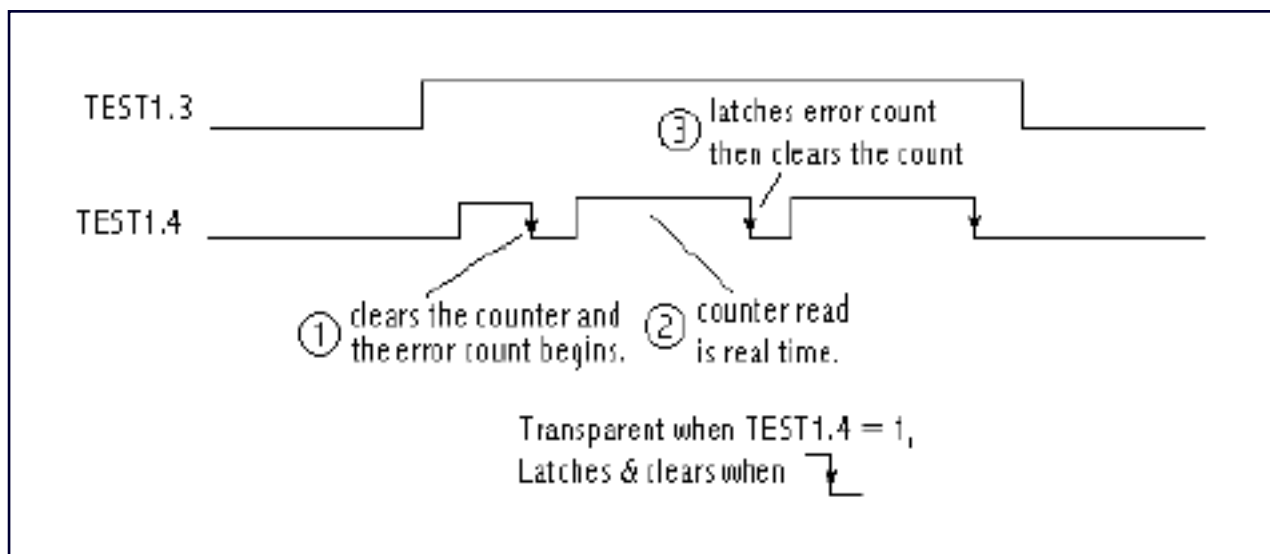

- o Point 1: After TEST1.3 is set high, toggling TEST1.4 clears the counter and starts the error

counter.

- o Point 2: The actual count is transparent to the user while TEST1.4 is set high. The user will then see the accumulated error count from the time of reset to setting TEST1.4 high.
- o Point 3: When TEST1.4 is cleared, the error count is latched and the count is cleared.

TEST1.2 =1 converts SR2.0 from TSLIP to Loss of Receive Clock (LORC).

TEST1.0 resets the one second timer.

2. **TEST3 (address AC)** can be used to modify the Attenuation Levels of the device

TEST3.7	TEST3.6	TEST3.5	TEST3.4	TEST3.1	Output
0	1	1	0	X	Rcvr additional 6dB attenuation pad
0	1	1	1	0	Rcvr 30dB monitor mode
0	1	1	1	1	Rcvr 12dB monitor mode
1	0	0	0	1	Bypass equalizer

Test Register Settings for the DS2152

1. **CCR6 (address 1E)** can be used for error counter functionality.

CCR1.6

Reset one second timer

CCR1.5

Testcount. (See figure below)

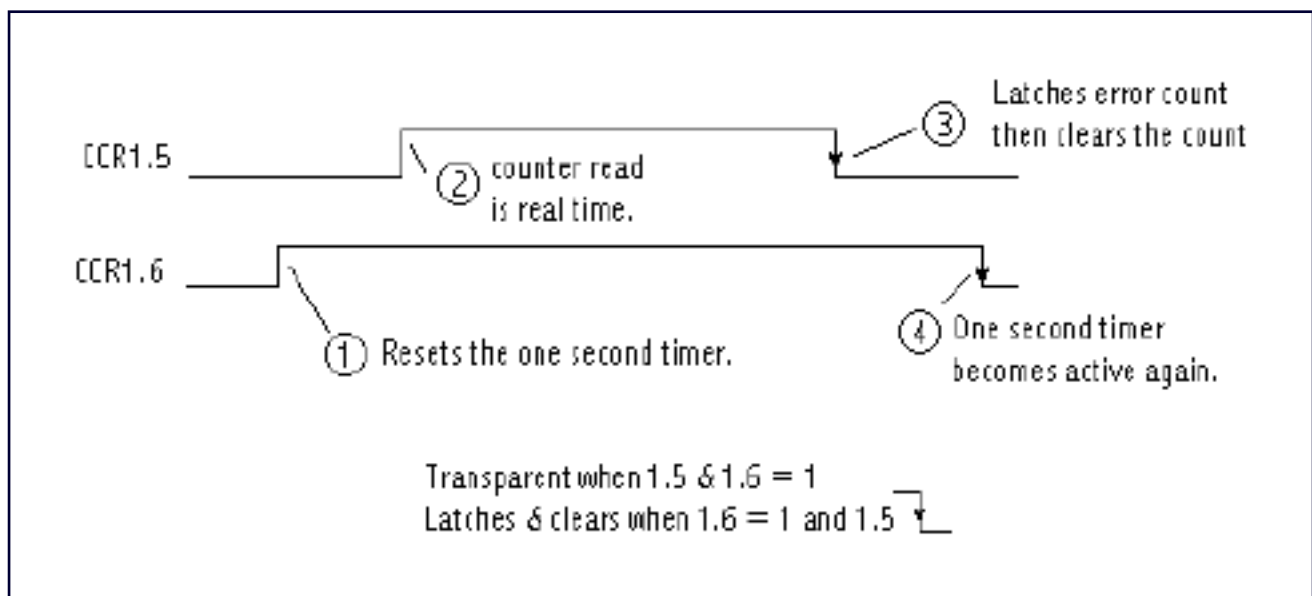

- o Point 1: Setting bit 6 high prohibits the 1 second timer from interfering with the error count.
- o Point 2: While bit 6 is high, asserting bit 5 allows the counter to begin. The counter read is real time.

2. **TEST2 (Address 09)** can be used to modify the Attenuation Levels of the device.

TEST2.6	TEST2.1	TEST2.0	Output
1	0	0	Rcvr additional 6dB attenuation pad
0	1	0	Rcvr 6dB monitor mode
0	0	1	Bypass equalizer

Test Register Settings for the DS2154

>

1. TEST2 (address19)

OUTPUT TEST MODES TEST2.7 and TEST2.6 can be used to force all outputs into a logic 1, logic 0 or 3-state.

TEST2.7	TEST2.6	Output
0	0	NORMAL OPERATION
0	1	3-STATE
1	0	LOGIC '0'
1	1	LOGIC '1'

TEST2.4 and TEST2.3 can be used for error counter functionality.

TEST2.4

Sample error counters. (See figure below)

TEST2.3

Set High to Enable Test1.4 to control sampling of error counters

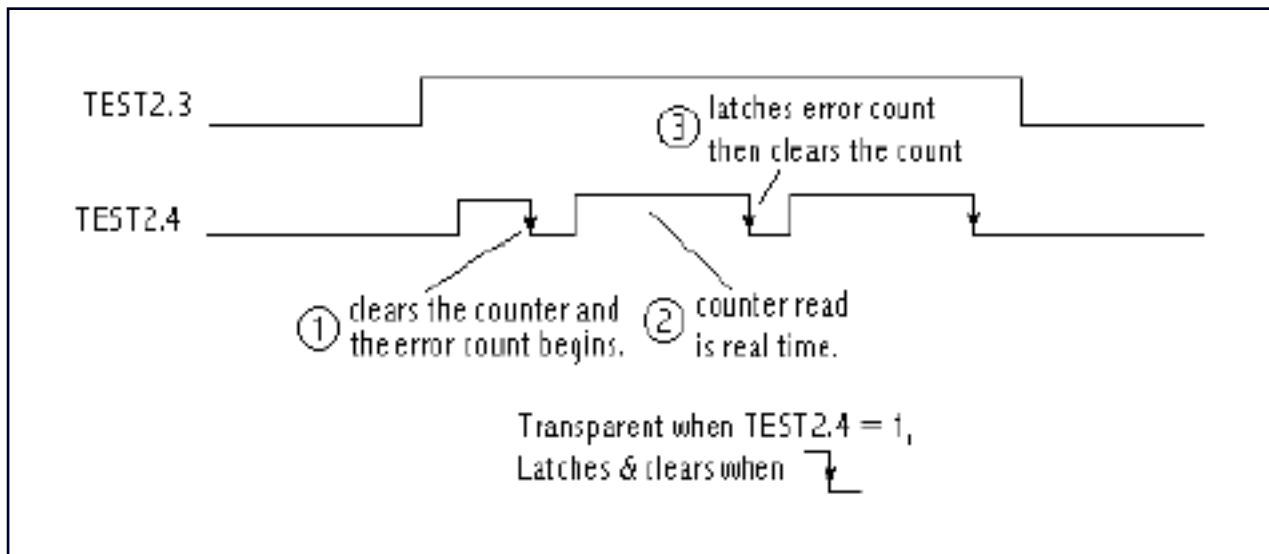

- Point 1: After TEST2.3 is set high, toggling TEST2.4 clears the counter and starts the error counter.
- Point 2: The actual count is transparent to the user while TEST2.4 is set high. The user will then see the accumulated error count from the time of reset to setting TEST2.4 high.
- Point 3: When TEST2.4 is cleared, the error count is latched and the count is cleared.

TEST2.2 will change the definition of RIR.7, RIR.6 and SR2.0.

TEST2.2	RIR.7	RIR.6	SR2.0
0	NORMAL (TESF)	NORMAL (TESE)	NORMAL (TSLIP)
1	RL1, RECEIVE LEVEL BIT 1	RLO, RECEIVE LEVEL BIT 0	LORC, LOSS OF RECEIVE CLOCK

RL1	RL2	Typical Level Received
0	0	+2dB to -7.5dB
0	1	-7.5dB to -15dB
1	0	-15dB to -22.5dB
1	1	Less than -22.5dB

Setting TEST2.1 = 1 will cause the receive framer to determine if a RCL state exist. Normally (TEST2.1 = 0) the LIU determines the RCL state.

Setting TEST2.0 = 1 will reset the one second timer.

2. **TEST3 (Address AC)** can be used to modify the Attenuation Levels of the device.

TEST3.6	TEST3.1	TEST3.0	Output
1	0	0	Rcvr additional 6dB attenuation pad
0	1	0	Rcvr 6dB monitor mode
0	0	1	Bypass equalizer

Application Note 355: <http://www.maxim-ic.com/an355>

More Information

For technical questions and support: <http://www.maxim-ic.com/support>

For samples: <http://www.maxim-ic.com/samples>

Other questions and comments: <http://www.maxim-ic.com/contact>

Related Parts

DS21352: [QuickView](#) -- [Full \(PDF\) Data Sheet](#) -- [Free Samples](#)

DS21354: [QuickView](#) -- [Full \(PDF\) Data Sheet](#) -- [Free Samples](#)

DS2152: [QuickView](#) -- [Full \(PDF\) Data Sheet](#) -- [Free Samples](#)

DS2154: [QuickView](#) -- [Full \(PDF\) Data Sheet](#) -- [Free Samples](#)

DS21552: [QuickView](#) -- [Full \(PDF\) Data Sheet](#) -- [Free Samples](#)

DS21554: [QuickView](#) -- [Full \(PDF\) Data Sheet](#) -- [Free Samples](#)

DS21Q42: [QuickView](#) -- [Full \(PDF\) Data Sheet](#) -- [Free Samples](#)

DS21Q44: [QuickView](#) -- [Full \(PDF\) Data Sheet](#) -- [Free Samples](#)

AN355, AN 355, APP355, Appnote355, Appnote 355

Copyright © by Maxim Integrated Products

Additional legal notices: <http://www.maxim-ic.com/legal>