

APPLICATION NOTE 3500

# Monitor Heat Dissipation in Electronic Systems by Measuring Active Component Die Temperature

*Abstract: Among the many tools available for thermal design, the most important is a parameter called junction-to-ambient thermal resistance ( $\theta_{JA}$ ). This note explains how to measure  $\theta_{JA}$ , and outlines the thermal-design process for circuits operating in still air. Its primary focus is a prototyping technique that allows direct measurement of the junction temperature of a silicon device while the device is operating. Circuits such as the MAX1811 linear battery charger serve as practical examples.*

## Basics of Junction Temperature and Thermal Resistance

The primary goal in thermal design is to limit the junction temperature of integrated circuits. In their lists of absolute maximum ratings (**Table 1**), all IC manufacturers include the maximum operating junction temperature. Thus, if a system is to maintain performance and reliability<sup>1</sup>, the board-level designer must ensure that no IC junction temperature exceeds its absolute-maximum rating.

**Table 1. MAX1811 Temperature-Related Absolute-Maximum Ratings Limit Junction Temperatures to 150°C**

Continuous Power Dissipation ( $T_A = +70^\circ\text{C}$ )	
8-Pin SO (derated 17.5mW/°C above +70°C)	1.4W
Operating Temperature Range (°C)	-40 to +85
Storage Temperature (°C)	-65 to +150
Maximum Die Temperature (°C)	+150
Lead Temperature (°C, soldering, 10 seconds)	+300

Direct measurement of an IC's junction temperature is difficult because its package blocks access to the junction. As an alternative, you can calculate the junction temperature using junction-to-case thermal resistance ( $\theta_{JC}$ ) and case-to-ambient thermal resistance ( $\theta_{CA}$ ), as shown in **Figure 1**. Thermal resistance is the most important parameter in determining the junction temperature of an IC: ( $\theta_{JA} = \theta_{JC} + \theta_{CA}$ ).

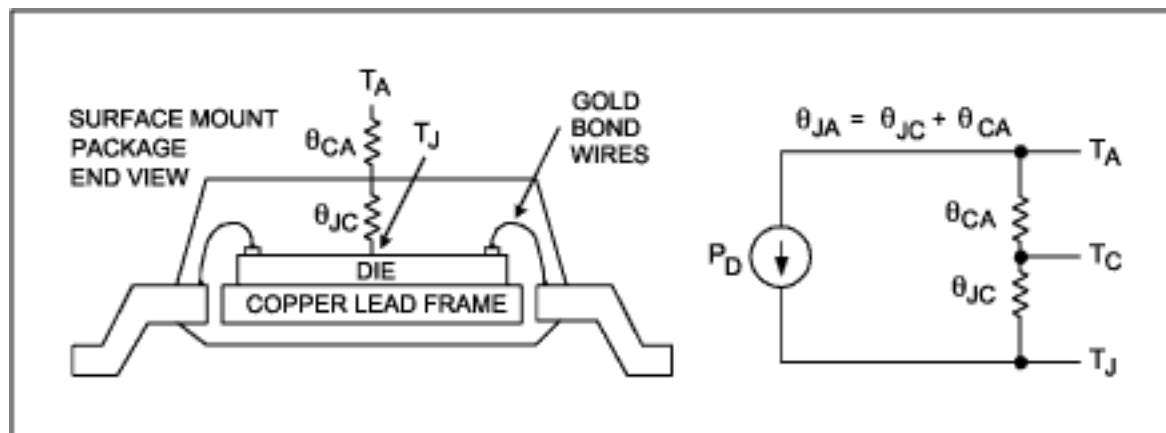

Figure 1. The electrical model of thermal behavior lets you calculate an IC's junction temperature using thermal resistance.

IC manufacturers that do not provide the  $\Theta_{JA}$  probably provide the inverse of  $\Theta_{JA}$ , which is the power-dissipation derating factor. As an example, the MAX1811 power-dissipation derating factor is 17.5mW/°C (from Table 1). The inverse of 17.5mW/°C gives  $\Theta_{JA} = 57^\circ\text{C/W}$ .

The thermal model in Figure 1 is analogous to Ohm's law when you equate temperature to voltage and power to current. That similarity is shown in the following example, which calculates junction temperature ( $T_J$ ) for a MAX1811 dissipating 1W ( $P_D$ ) in a 30°C ambient temperature:

$$V = I * R \text{ (Ohm's law)}$$

$$T = P * \Theta \text{ (Thermal model)}$$

$$T_J = P_D * (\Theta_{JC} + \Theta_{CA}) + T_A$$

$$T_J = 1W * 57^\circ\text{C/W} + 30^\circ\text{C}$$

$$T_J = 87^\circ\text{C}$$

To better understand the thermal model of Figure 1, consider what  $\Theta_{JC}$  and  $\Theta_{CA}$  actually represent.  $\Theta_{JC}$  is derived from IC-package characteristics such as die size, lead frame, and body material. Those characteristics are specific to the IC package, and cannot be changed.<sup>2</sup>  $\Theta_{CA}$ , on the other hand, is directly related to external variables such as forced-air cooling, package mounting, trace width, and external heat sinks. Thus,  $\Theta_{CA}$  represents the heat-transfer path from the IC (packaged and mounted) to the atmosphere.

In calculating the heat-transfer path of an electronic system, you must consider the thermal conductivity of materials in that path. Thermal conductivity measures the ability of a material to conduct heat. As shown in **Table 2**, thermal conduction occurs primarily through the metal portions of the system; the plastic (epoxy) portions contribute very little to the heat path.

**Table 2. Thermal Conduction of Common Electronic-System Materials**

Material	Thermal Conductivity(W/m*°C)
Aluminum (Al)	216
Copper (Cu)	393
Gold (Au)	291
Silver (Ag)	417
Silicon (Si)	145
Epoxy	0.2
Thermally Conductive Epoxy	0.8
Air	0.03

Because  $\Theta_{CA}$  depends on external variables,  $\Theta_{JA}$  varies according to its environment. For that reason, IC manufacturers ensure correct and meaningful data<sup>3</sup> by maintaining standard test conditions during the measurement of  $\Theta_{JA}$ . These standard test conditions are described in several documents called JESD51, which are produced by the Electronic Industries Alliance (EIA) and JEDEC Solid State Technology Association. (All those documents can be downloaded for free [here](#).)

The quantity  $\Theta_{JA}$  provided by IC manufacturers and measured according to JESD51 can be used for comparing the thermal properties of different devices housed in the same electronic package, and for similar devices housed in different electronic packages.<sup>4</sup> Consider, for example, the thermal properties of a speaker driver (MAX4366) housed in different packages:

$\Theta_{JA}$  for the MAX4366 in an 8-pin SOT23 package is 103°C/W.

$\Theta_{JA}$  for the MAX4366 in an 8-pin, thin QFN package is 41°C/W.

Obviously, an 8-pin, thin QFN package beats the 8-pin SOT23 in conducting heat away from a MAX4366 die. For a MAX4366 housed in an 8-pin thin QFN package and operating in the JEDEC51 standard environment, we can estimate that its junction temperature rises 41°C above ambient for every watt dissipated in the die.

Take caution when estimating junction temperature using the  $\theta_{JA}$  value specified by a manufacturer, because any difference between your application and the manufacturer's test environment can produce very different  $\theta_{JA}$  values. For example, if a manufacturer abides by the JESD51 standard and measures  $\theta_{JA}$  with the device operating in one cubic foot of still air, that value will not accurately predict thermal behavior for the same device operating in a cell phone, where the amount of still air is very limited.

## Measuring Thermal Resistance in an Application

Because  $\theta_{JA}$  depends on the layout and other physical factors in a design, the  $\theta_{JA}$  value specified using the JESD51 standard might not apply in a given application. As mentioned, the standard JESD51 environment is one cubic foot of still air with the device mounted on a relatively large, standard printed circuit board—conditions very different from those of many applications today. PDAs, laptops, cell phones, and digital cameras pack many ICs onto small circuit boards in extremely small cases.

For prototyping, you can ensure compliance with the IC's absolute maximum ratings by measuring  $\theta_{JA}$  directly, even in a harsh application-specific environment. (Because the procedure outlined below can place undue stress on the device, it is considered a prototyping tool and not recommended for production devices.) Three parameters are necessary to measure  $\theta_{JA}$ :

$$\theta_{JA} = \frac{T_J - T_A}{P}$$

where

$P_D$  = IC power dissipation

$T_A$  = ambient temperature

$T_J$  = IC junction temperature.

$P_D$  and  $T_A$  are easily obtained, but  $T_J$  is not easily measured because the IC package blocks access to the internal junction. You can, however, measure  $T_J$  using an existing on-chip diode as the temperature-sensing device. Most ICs include a diode for protection against electrostatic discharge (ESD), which is also suitable for use as a temperature-sensing device.

## Finding and Characterizing the Temperature-Sensing ESD Diode

To determine the junction temperature ( $T_J$ ) of an IC, you need an equation for the behavior of an ESD diode vs. temperature. Obtaining that diode equation is a four-step process. You then use the equation to calculate  $T_J$  as a function of the ESD diode's forward voltage.

### STEP 1: Find a suitable ESD diode within the IC

First, find an internal ESD diode that can be forward biased while the IC is operating. Some data sheets show the location of internal ESD diodes explicitly (see **Figure 6** of the MAX1169 data sheet, for example). Otherwise, deduce the location of ESD diodes from the IC's table of absolute-maximum ratings.

A strong clue in locating ESD diodes using the absolute-maximum ratings is the number "0.3V," which is the forward voltage for a diode at its maximum junction temperature (usually 150°C for Maxim devices). **Table 3**, for example, includes three "0.3V" numbers that allude to the location of diodes. **Figure 2** shows that the

terminals IN, BATT, SELI, CHG, EN, and SELV each include ESD diodes that clamp the voltage at those pins to no more than a diode drop below ground. SELV also includes a diode that clamps its voltage to no more than a diode drop above  $V_{IN}$ .

**Table 3. Entry from the MAX1811 Absolute-Maximum Ratings Shows "0.3V" Numbers Alluding to the Presence of ESD Diodes**

IN, BATT, SELI, CHG, EN to GND	-0.3V to 7V
SELV to GND	-0.3V to ( $V_{IN} + 0.3V$ )

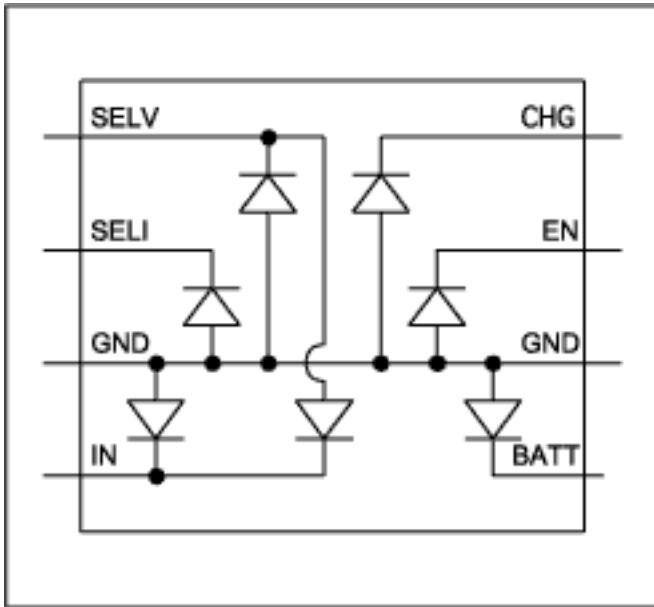

Figure 2. MAX1811 on-chip ESD diodes allow direct measurement of junction temperature.

To ensure that you've interpreted the absolute maximum ratings table correctly and that the ESD diodes in question are suitable for use as temperature-sensing devices, check them with a standard multimeter in diode-check mode. ESD diodes that clamp digital inputs to GND are well suited for use as temperature-sensing devices.

## STEP 2: Characterize the ESD diode across temperature

When you find a suitable ESD diode, you must characterize it over temperature. For accurate measurements you should (ideally) characterize each device separately, but if a large number of devices must be tested, a common practice is to represent the entire batch by characterizing 10 to 12 parts and averaging the data<sup>5</sup>. Any part-to-part mismatch is then due to dispersion of the diode characteristics (the ideality factor). When testing a large number of devices, that factor ultimately determines the uncertainty of the temperature measurement.

Characterization curves for the MAX1811 ESD diode (**Figure 3**) were taken on the diode between SELV and GND. The device under test (in this case, the MAX1811) must be unpowered with all pins floating, except those used for connections to the temperature-sensing device (**Figure 4**).

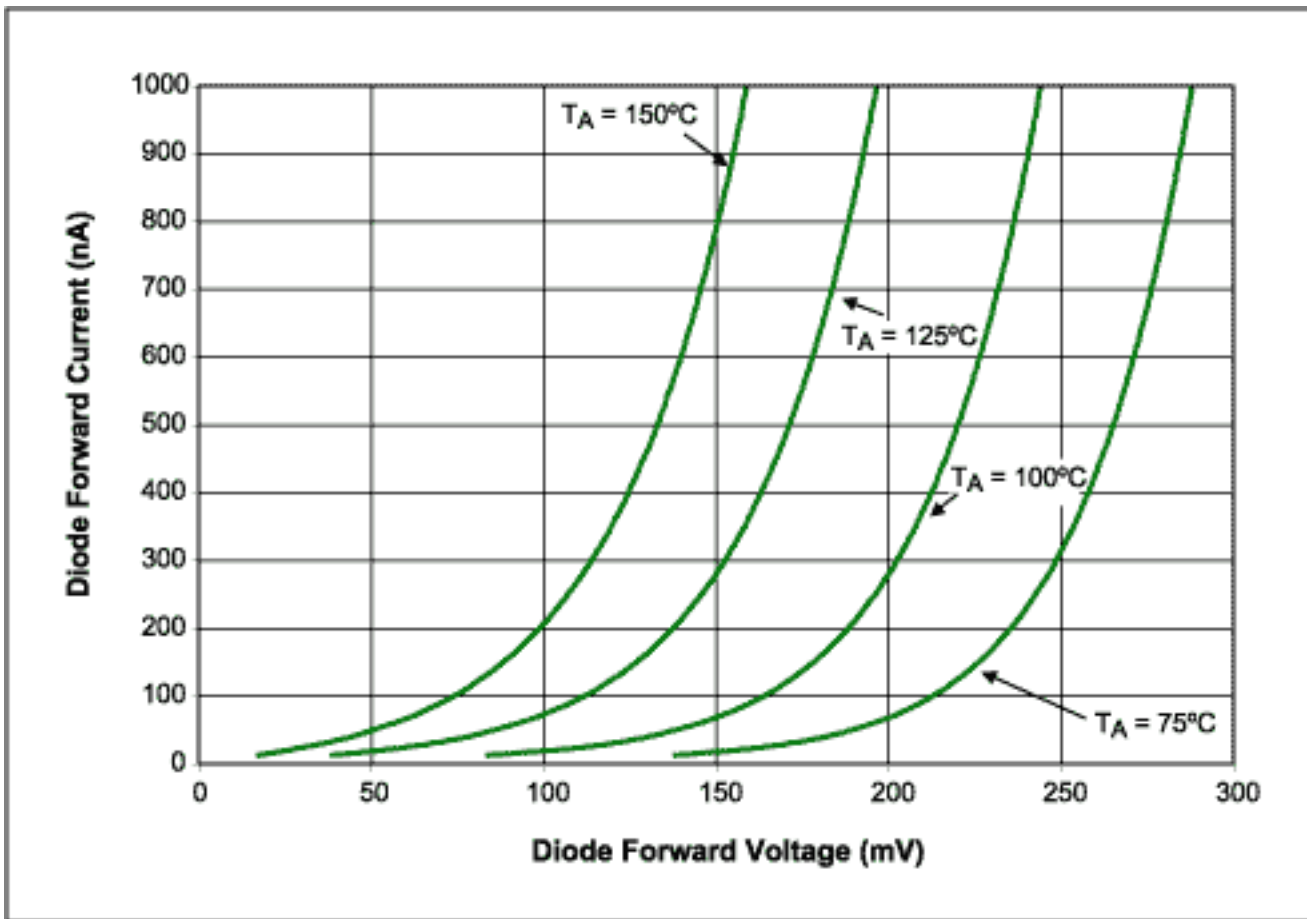

Figure 3. MAX1811 ESD-Diode characterization curves show that forward-diode voltage decreases with temperature.

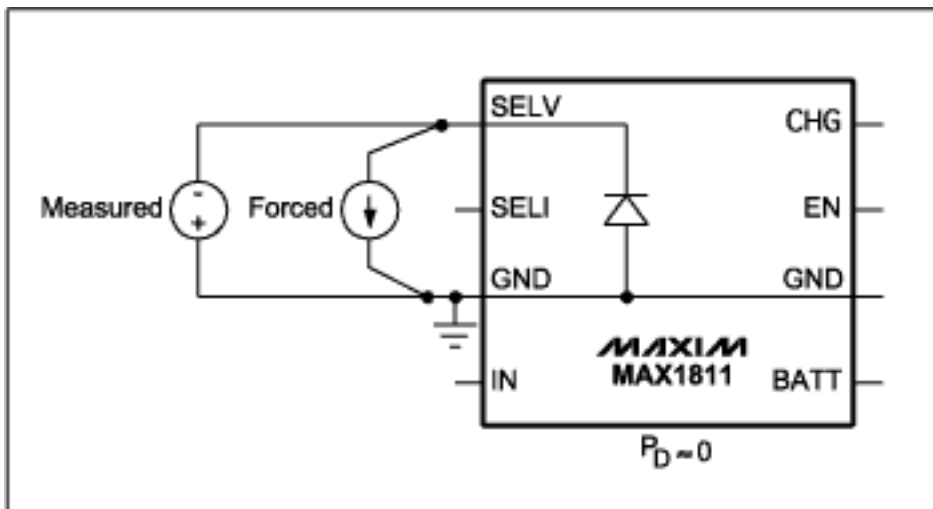

Figure 4. Characterizing the on-chip ESD diode while the device is not dissipating power ensures that the ambient temperature equals the junction temperature.

By characterizing the ESD diode with an unpowered device and allowing the temperature to stabilize before taking measurements, you ensure that the ambient temperature equals the junction temperature. Self-heating is absent because the only power dissipated in the DUT is a minuscule amount in the diode. As a result, the diode temperature equals the ambient temperature.

As shown in Figure 4, the ESD diode is excited by a current source. Several factors determine the amplitude of the excitation current. It should be sufficiently large to ignore the effect of noise and diode-leakage currents (for most devices, that means the excitation current should be greater than 50nA). It should be small enough to comply with the device absolute-maximum ratings. (For Maxim devices, that generally means the excitation current should be less than 2mA.)

The excitation current should also be sufficiently small to avoid affecting the device performance. That limit can be found experimentally, by monitoring vital characteristics of the device while forcing current through the ESD diode. For the MAX1811, currents larger than 3 $\mu$ A increase its charge current beyond the normal operating conditions.

The excitation current should be small enough to avoid significant self-heating, but that phenomenon usually doesn't come into play, given the 2mA maximum limit established above. MAX1811 calibration curves are taken with excitation currents from 1nA to 1000nA. Calibration curves for the MAX1811 ESD diode (Figure 3) show that forward voltage for a given forward current decreases with temperature.

### STEP 3: Obtain a test curve to verify the characterization data

The data obtained in Step 2 were taken with an unpowered device. To ensure that no major shifts occur when the DUT is powered, obtain a test curve with the device powered up in its lowest power (quiescent) state.

**Figure 5** compares a characterization curve for the MAX1811 ( $T_A = 75^\circ\text{C}$ ) with a test curve at  $T_A = 75^\circ\text{C}$  for the part powered in its quiescent state. When powered from 5V in its quiescent state, the MAX1811 draws approximately 1mA. Using the  $\theta_{JA}$  value given by Maxim (57 $^\circ\text{C}/\text{W}$ ), this 5mW power dissipation should produce a junction rise above ambient of 0.3 $^\circ\text{C}$ . Because the test curve in Figure 5 shows a slight rise in temperature without major shifts in the curve shape, the calibration data is deemed trustworthy.

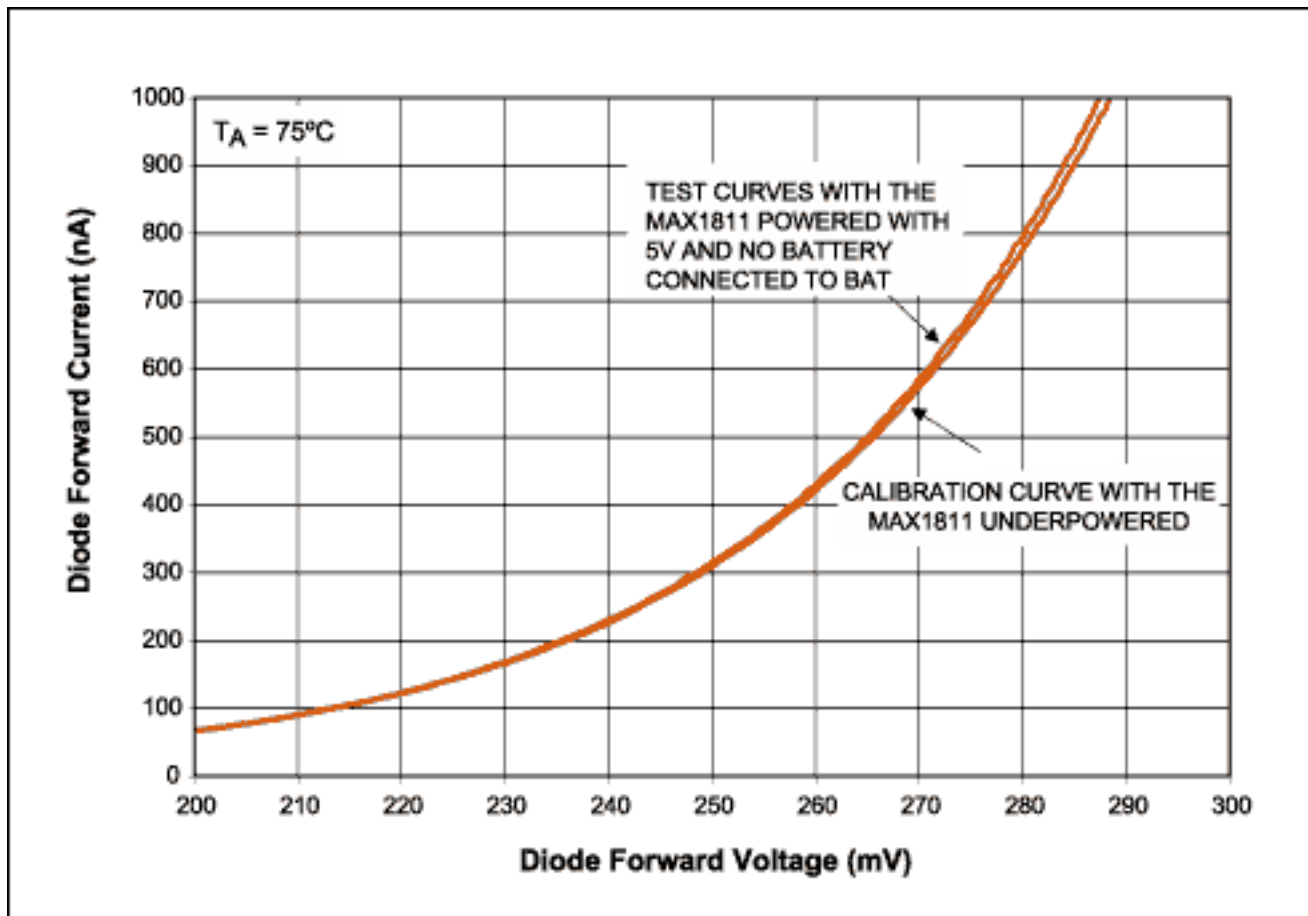

Figure 5. Test curve for the MAX1811 under power shows no major shifts in diode forward voltage, which ensures trustworthy data.

### STEP 4: Create a diode equation from the characterization data

Now that Step 3 has validated the characterization data, the next and final step is to create a diode equation.

Figure 6 presents the same data as shown in Figure 3, but plots diode voltage vs. temperature at a constant diode current. The slope of the line plotted in Figure 6 is the K factor, which shows that forward diode voltage decreases 1.746mV/°C when the forward current is a constant 900nA. Because that value (900nA) is too large to be affected by noise or leakage currents and too small to stress the ESD diode or cause significant self-heating, it can serve as the excitation current.

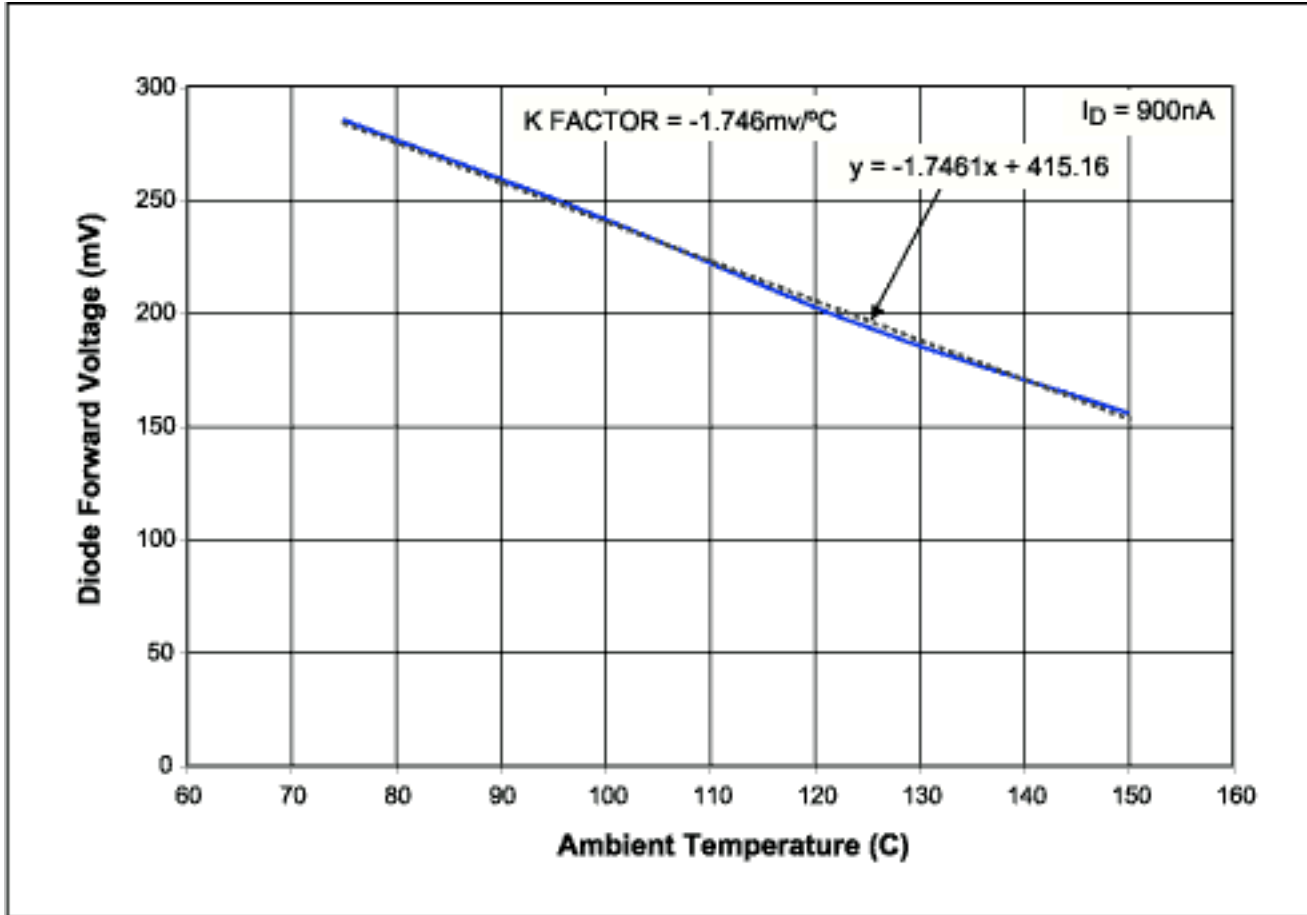

Figure 6. The MAX1811 ESD-diode equation shows that the diode forward voltage decreases 1.746mV/°C.

## Measuring $T_J$ with an Internal ESD Diode

Calculating the MAX1811 junction temperature is simple when using the MAX1811 diode equation from Figure 6. Under normal operating conditions (**Figure 7**) in a 60°C environment with a 900nA excitation current, forward voltage on the ESD diode between SELV and GND measures 233.6mV. Using the equation obtained in Step 4 and shown in Figure 6, the junction temperature is calculated as follows:

$$V_D = -1.7461 \frac{\text{mV}}{^\circ\text{C}} \times T_J + 415.16 \text{mV} \quad (\text{for } 900\text{nA excitation current})$$

Thus,

$$T_J = \frac{V_D - 415.16 \text{mV}}{-1.7461 \frac{\text{mV}}{^\circ\text{C}}}$$

Substituting for  $V_D$ ,

$$T_J = \frac{233.6 \text{mV} - 415.16 \text{mV}}{-1.7461 \frac{\text{mV}}{^\circ\text{C}}}$$

Therefore,  
 $T_J = 103.9^\circ\text{C}$

Now that the junction temperature ( $T_J$ ) is known, you can calculate the application-specific  $\Theta_{JA}$  as follows:

$$\Theta_{JA} = \frac{T_J - T_A}{P_D}$$

$$\Theta_{JA} = \frac{103.9^\circ\text{C} - 60^\circ\text{C}}{(5\text{V} - 3.6\text{V}) \times 0.439\text{A}}$$

$$\Theta_{JA} = \frac{103.9^\circ\text{C} - 60^\circ\text{C}}{0.6146\text{W}}$$

$$\Theta_{JA} = 71.4 \frac{^\circ\text{C}}{\text{W}}$$

Maxim gives the MAX1811  $\Theta_{JA}$  as  $57^\circ\text{C}/\text{W}$ , yet the application-specific value calculated above is  $71.4^\circ\text{C}/\text{W}$ , representing a significant decrease in thermal conductivity. The decrease is reasonable, considering the difference in conditions specified by JESD51 and those in which the device was actually tested. The major factors reducing an application-specific  $\Theta_{JA}$  from the published  $\Theta_{JA}$  value are the enclosure size, the amount of copper on the board (to spread the heat), and the amount of board surface exposed to the atmosphere.

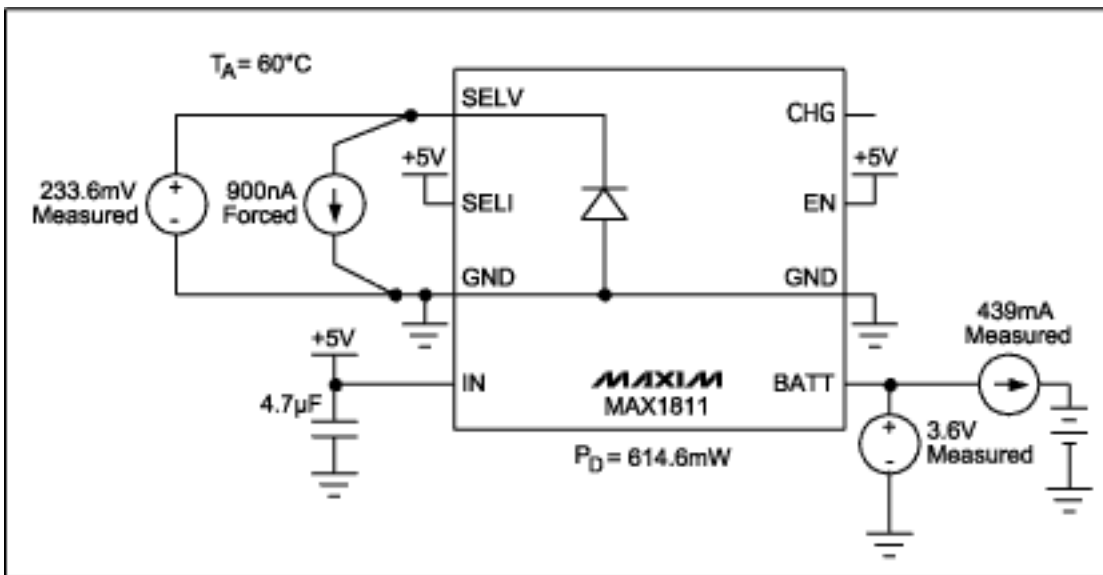

Figure 7. Measuring forward voltage for the MAX1811 ESD diode in normal operation.

## Testing the MAX1811 Thermal-Control Loop

The MAX1811 includes a thermal control loop that maintains  $T_J \leq 125^\circ\text{C}$  (typ)<sup>6</sup> by limiting the battery charge current. This feature can easily be tested using the above information. To ensure that the IC limits  $T_J$  to  $\leq 125^\circ\text{C}$ , increase its power dissipation until the charge current starts to limit. One set of conditions that triggers operation of the thermal control loop is  $T_A = 60^\circ\text{C}$ ,  $V_{IN} = 5.5\text{V}$ , and  $V_{BATT} = 2.7\text{V}$ . In that operating environment, the MAX1811 reduces its normal battery-charging current from 439mA to 340mA (**Figure 8**).

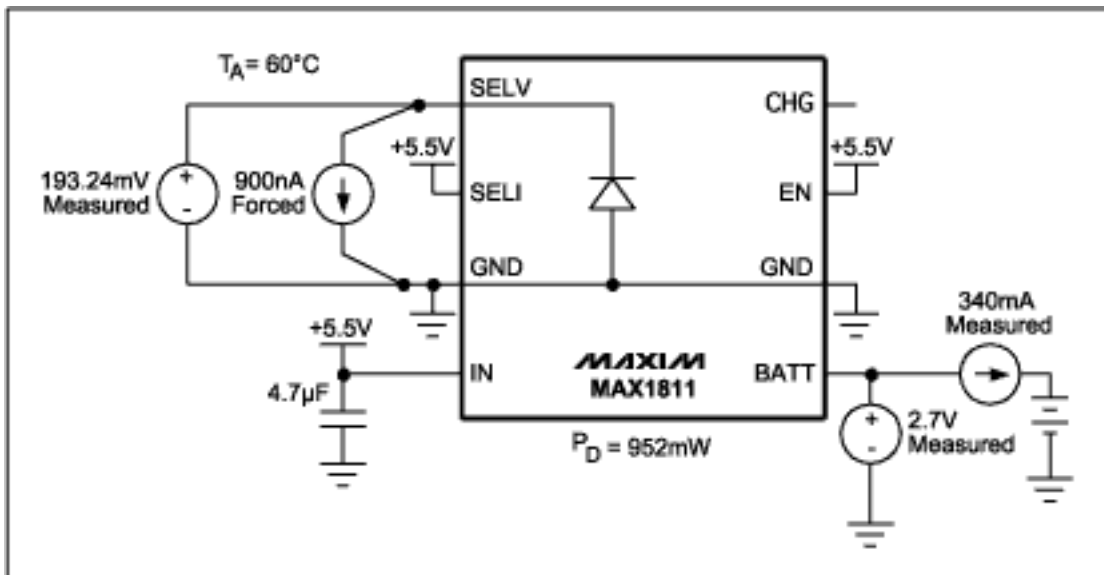

Figure 8. Measuring the MAX1811 ESD Diode while operating with an active thermal-control loop.

With the thermal control loop active in a 60°C environment, the forward voltage on the ESD diode between SELV and GND measures 193.24mV, with an excitation current of 900nA. Using the equation obtained in Step 4 and shown in Figure 6, you can calculate the junction temperature as follows:

$$T_J = \frac{V_D - 415.16\text{mV}}{-1.7461 \frac{\text{mV}}{^\circ\text{C}}} \quad (\text{for } 900\text{nA excitation current}).$$

$$T_J = \frac{193.24\text{mV} - 415.16\text{mV}}{-1.7461 \frac{\text{mV}}{^\circ\text{C}}}$$

$$T_J = 127.095^\circ\text{C}$$

The calculations above verify that the MAX1811 thermal control loop limits  $T_J$  to  $\leq 125^\circ\text{C}$  (typ).

Because the MAX1811 test environment for taking normal operation data was the same as the test environment used for testing the thermal control loop,  $\theta_{JA}$  values for those two configurations are similar, and slight variations can be attributed to changes in power dissipation.  $\theta_{JA}$  for operation of the thermal loop is calculated as follows:

$$\theta_{JA} = \frac{T_J - T_A}{P_D}$$

$$\theta_{JA} = \frac{127.095^\circ\text{C} - 60^\circ\text{C}}{(5\text{V} - 2.7\text{V}) \times 0.340\text{A}}$$

$$\theta_{JA} = \frac{103.9^\circ\text{C} - 60^\circ\text{C}}{0.952\text{W}}$$

$$\theta_{JA} = 70.5 \frac{^\circ\text{C}}{\text{W}}$$

## Conclusion

Successful thermal designs allow enough heat dissipation to ensure that no component exceeds its maximum allowable temperature. The most important thermal-design parameter for that purpose is  $\Theta_{JA}$ . Because  $\Theta_{JA}$  depends on environmental factors such as air flow, package mounting, and the printed circuit board, you should measure it under the conditions present in the end application.

As shown in the examples, you can measure  $\Theta_{JA}$  for the product environment by using on-chip ESD diodes as temperature-sensing elements. Experimental results show that such  $\Theta_{JA}$  values are 14°C/W higher than those measured in the standard conditions of a JEDEC51 environment. Measuring  $\Theta_{JA}$  in the product environment also produces a more accurate figure for use in thermal design, ultimately ensuring system reliability by allowing more efficient heat-dissipation mechanisms. Consequently, you can reduce costs through the use of accurately sized and optimized heat sinks, fans, and PCB area.

## Additional Reading Available:

- Application note 862, "[HFAN-08.1: Thermal Considerations of QFN and Other Exposed-Paddle Packages.](#)" Gives specific examples, with data, of how board size and other system variables affect heat transfer.
- Application note 1057, "[Compensating for Ideality Factor and Series Resistance Differences between Thermal Sense Diodes.](#)" Reviews the temperature-dependant diode equation, and discusses how additional series resistance degrades measurements.
- Application note 1832, "[Power Supply Engineer's Guide to Calculate Dissipation For MOSFETs In High-Power Supplies.](#)" Discusses thermal resistance and power dissipation in switching power supplies, while focusing on practical methods for choosing components based on their power ratings.
- Application note 961, "[Thermal Protection in Low-Cost Systems, Part 1.](#)" Describes low-cost circuits that protect systems from thermal damage.
- Application note 689, "[IC Temperature Sensors Find the Hot Spots.](#)" Reviews the use of temperature sensors used to monitor hot spots.

## Notes

<sup>1</sup>EIA/JESD51. Methodology for the Thermal Measurement of Component Packages (Single Semiconductor Device). Page 2, Section 3. (1995). <http://www.jedec.org>

<sup>2</sup>HFAN-08.1: Thermal Considerations of QFN and Other Exposed-Paddle Packages. Page 4. (2001). <http://www.maxim-ic.com>

<sup>3</sup>EIA/JESD51. Methodology for the Thermal Measurement of Component Packages (Single Semiconductor Device). Page 2, Section 3. (1995). <http://www.jedec.org>

<sup>4</sup>EIA/JESD51-1, Integrated Circuits Thermal Measurement Method-Electrical Test Method (Single Semiconductor Device). Page 1, Section 1.1. (1995). <http://www.jedec.org>

<sup>5</sup>EIA/JESD51-1, Integrated Circuits Thermal Measurement Method-Electrical Test Method (Single Semiconductor Device). Page 16, Section 3.3. (1995). <http://www.jedec.org>

<sup>6</sup>MAX1811 USB-Powered Li+ Charger. Page 6, Thermal-Control Circuitry. <http://www.maxim-ic.com>.

---

Application Note 3500: [www.maxim-ic.com/an3500](http://www.maxim-ic.com/an3500)

## More Information

For technical support: [www.maxim-ic.com/support](http://www.maxim-ic.com/support)

For samples: [www.maxim-ic.com/samples](http://www.maxim-ic.com/samples)

Other questions and comments: [www.maxim-ic.com/contact](http://www.maxim-ic.com/contact)

---

## Automatic Updates

Would you like to be automatically notified when new application notes are published in your areas of interest?  
[Sign up for EE-Mail™.](#)

---

### **Related Parts**

MAX1811: [QuickView](#) -- [Full \(PDF\) Data Sheet](#) -- [Free Samples](#)

AN3500, AN 3500, APP3500, Appnote3500, Appnote 3500

Copyright © by Maxim Integrated Products

Additional legal notices: [www.maxim-ic.com/legal](http://www.maxim-ic.com/legal)