



APPLICATION NOTE 3422

DS26502 Hardware Mode

Abstract: The DS26502 data sheet contains all the information required to implement the DS26502 in a wide variety of applications. The data sheet was written with the software-mode user in mind. It therefore contains information required to set up the DS26502 using control registers to enable functionality that is not available when using hardware mode.

This application note provides a focused view of the DS26502 functionality in hardware mode by excluding the information in the data sheet that is only applicable when using software mode.

Introduction

There are two major modes of operation for the DS26502: software and hardware mode. The "mode" refers to the method used to control the device's functionality. Applications implementing software mode use a microcontroller's serial or parallel bus to communicate to the control registers contained in the DS26502. In hardware mode, the functions of the serial/parallel communication bus pins are reassigned so that the logic state of the pins provides direct control of the DS26502's internal functionality.

When Should Hardware Mode Be Used?

The advantage of using the DS26502 in hardware mode is that no microcontroller is required to control the functionality.

Each application has specific requirements that determine whether or not hardware mode may be used. The designer's primary consideration is to determine whether any of the features available only in software mode are required in the application. Table 1 lists all the software mode features not available in hardware mode. The register bit position and the name are provided to easy reference to the complete functionality description in the DS26502 data sheet.

Hardware Mode Implementation

The DS26502 functionality is controlled by external pins in hardware mode. Table 2 is a reference for the functionality of the software-mode bit positions and the corresponding pin used in hardware mode to control the DS26502.

While some software-controllable features are totally eliminated in hardware mode, other features are present but the functionality cannot be changed. The functionality of the unchangeable features, provided in Table 3, was carefully chosen to perform as expected in normal applications using hardware mode. A complete description of the hardware mode functionality for each pin is provided in Table 4. **Figures 1** through **Figure 4** are block diagrams of DS26502 functionality in hardware mode. The diagrams are similar to the software-mode counterparts in the data sheet. In contrast to the block diagrams provided in the data sheet, the external pins of the DS26502 in the figures here replace references to the control registers. Functionality for software-mode only has also been removed.

Although most DS26502 applications implement software mode, hardware mode remains a viable option for many customers. Using this application note along with the DS26502 data sheets provides the information required to get a hardware-mode application up and running with minimal time and effort.

Table 1. Software Mode Features Eliminated in Hardware Mode

Register	Description
TSTRREG	Test Reset Register
IDR	Device Identification Register
INFO1	Information Register 1
INFO2	Information Register 2
IIR	Interrupt Information Register
SR1	Status Register 1
IMR1	Interrupt Mask Register 1
SR2.7	Receive Yellow Alarm Clear Event
SR2.6	Receive Alarm Indication Signal Clear Event
SR2.5	Receive Loss Of Signal Clear Event
SR2.4	Receive Loss of Frame Clear Event
SR2.3	Receive Yellow Alarm Condition
IMR2	Interrupt Mask Register 2
SR3	Status Register 3
IMR3	Interrupt Mask Register 3
SR4	Status Register 4
IMR4	Interrupt Mask Register 4
INFO3	Information Register 3
RAF	Receive Align Frame Register
RNAF	Receive Non-Align Frame Register
RSIAF	Receive Si Bits of the Align Frame
RSINAF	Receive Si Bits of the Non-Align Frame
RRA	Receive Remote Alarm
RSa4	Receive Sa4 Bits
RSa5	Receive Sa5 Bits
RSa6	Receive Sa6 Bits
RSa7	Receive Sa7 Bits
RSa8	Receive Sa8 Bits
TEST1-16	Test Register 1-16

Table 2. Hardware Mode Pin Control/Register Reference

Position	Pin	Name
IOCR1.5	RSM	RS_8K Mode Select
IOCR1.2	TSM	TS_8K_4 Mode Select
T1RCR2.5	HBE	Receive B8ZS Enable
T1TCR2.7	HBE	Transmit B8ZS Enable
MCREG.7	TMODE3	Transmit Mode Configuration 3
MCREG.6	TMODE2	Transmit Mode Configuration 2
MCREG.5	TMODE1	Transmit Mode Configuration 1
MCREG.4	TMODE0	Transmit Mode Configuration 0
MCREG.3	RMODE3	Receive Mode Configuration 3
MCREG.2	RMODE2	Receive Mode Configuration 2
MCREG.1	RMODE1	Receive Mode Configuration 1
MCREG.0	RMODE0	Receive Mode Configuration 0
TPCR.1	TCSS1	Transmit Clock (TX CLOCK) Source Select 1
TPCR.0	TCSS0	Transmit Clock (TX CLOCK) Source Select 0
SR2.2	RAIS	Receive Alarm Indication Signal
SR2.1	RLOS	Receive Loss Of Signal Condition
SR2.0	RLOF_CCE	Receive Loss of Frame Condition
E1RCR.5	HBE	Receive HDB3 Enable
E1TCR.1	HBE	Transmit HDB3 Enable
LBCR.2	RLB	Remote loopback enabled
LIC1.7	L2	Line Build-Out Select 2
LIC1.6	L1	Line Build-Out Select 1
LIC1.5	L0	Line Build-Out Select 0
LIC2.4	TAIS	Transmit Alarm Indication Signal
LIC2.3	JACKS	Jitter Attenuator Mux
LIC4.7	MPS1	MCLK Prescaler 1
LIC4.6	MPS0	MCLK Prescaler 0

Table 3. Hardware Mode Default Functionality

Position	Name	Hardware Mode Function
IOCR1.6	RS_8K Mode Select 2	T1 Mode: (when RMS = 0)do not pulse double-wide in signaling frames E1 Mode: (when RMS = 1)RS_8K outputs CAS multiframe boundaries
IOCR1.4	RLOF_CCE Output Function	receive loss of frame (RLOF)
IOCR1.3	Composite Clock Sync Mode_ Transmit Signaling Double-Wide Sync	(CC64K) 8kHz reference, (T1) normal sync pulses
IOCR1.1	TS_8K_4 I/O Select	TS_8K_4 is an input
IOCR1.0	Output Data Format	bipolar data at TPOS and TNEG
IOCR2.7	RCLK	Invert no inversion
IOCR2.6	TCLK	Invert no inversion
IOCR2.5	RS_8K Invert	no inversion
IOCR2.4	TS_8K_4	Invert no inversion
T1RCR1.6	Auto Resync Criteria	resync on OOF or RLOS event
T1RCR1.5	T1RCR1.4 Out Of Frame Select Bits	Out Of Frame Criteria 2/4 frame bits in error
T1RCR1.3	Sync Criteria	In D4 Framing Mode: search for Ft pattern, then search for Fs pattern In ESF Framing Mode: search for FPS pattern only
T1RCR1.2	Sync Time	qualify 10 bits

T1RCR1.1	Sync Enable	auto resync enabled
T1RCR1.0	Resynchronize	No manual resynchronization of the receive side framer allowed
T1RCR2.1	Receive Japanese CRC6 Enable	use ANSI/AT&T/ITU CRC6 calculation (normal operation)Japanese CRC6 not available
T1RCR2.0	Receive Side D4 Yellow Alarm Select	zeros in bit 2 of all channels
T1TCR1.7	Transmit Japanese CRC6 Enable	use ANSI/AT&T/ITU CRC6 calculation (normal operation)Japanese CRC6 not available
T1TCR1.6	Transmit F-Bit Pass-Through	F bits sourced internally
T1TCR1.5	Transmit CRC Pass-Through	source CRC6 bits internally
T1TCR1.0	Transmit Yellow Alarm	cannot transmit yellow alarm
T1TCR2.6	Transmit Fs-Bit Insertion Enable	Fs-bit insertion enabled
T1TCR2.4	Bit 4/F-Bit Corruption Type 2	No bit corruption support
T1TCR2.3	F-Bit Corruption Type 1	No bit corruption support
T1TCR2.2	Transmit-Side D4 Yellow Alarm Select	0s in bit 2 of all channels
T1TCR2.0	Transmit-Side Bit 7 Zero-Suppression Enable	no stuffing occurs
T1CCR.4	Transmit RAI-CI Enable	do not transmit the ESF RAI-CI code
T1CCR.3	Transmit AIS-CI Enable	do not transmit the AIS-CI code
T1CCR.1	Pulse-Density Enforcer Enable	disable transmit pulse-density enforcer
TPCR.7	Transmit PLL Output Frequency Select 1	in hardware mode, use TMODE pins
TPCR.6	Transmit PLL Output Frequency Select 0	in hardware mode, use TMODE pins
TPCR.5	PLL_OUT Select	PLL_OUT is sourced directly from the TX PLL
TPCR.4	Transmit PLL Input Frequency Select 0	in hardware mode, use RMODE pins
TPCR.3	Transmit PLL Input Frequency Select 1	in hardware mode, use RMODE pins
TPCR.2	Transmit PLL_CLK Source Select	Use the recovered network clock. This is the same clock available at the RCLK pin (output)
E1RCR.6	Receive Loss Of Signal	RLOS declared upon 255 consecutive zeros (125µs)
E1RCR.2	Frame Resync Criteria	resync if FAS received in error three consecutive times
E1RCR.1	Sync Enable	auto resync enabled
E1RCR.0	Resync	No manual resync
E1TCR.7	Transmit Time Slot 0 Pass-Through	FAS bits/Sa bits/remote alarm sourced internally from the TAF and TNAF registers
E1TCR.4	Transmit International Bit Select	sample Si bits at TSER pin
BOCC.4	Receive BOC Enable	receive BOC function disabled
BOCC.3	Receive BOC Reset	No manual reset of the BOC circuitry
BOCC.2	Receive BOC Filter Bit 1	sets the number of consecutive patterns that must be received without error prior to an indication of a valid message
BOCC.1	Receive BOC Filter Bit 0	sets the number of consecutive patterns that must be received without error prior to an indication of a valid message
BOCC.0	Send BOC	Do not transmit BOC code
LBCR.3	Local Loopback	Local loopback disabled
LIC1.4	Receive Equalizer Gain Limit	T1 Mode: -36dB (long haul)E1 Mode: -43dB (long haul)
LIC1.3	Jitter Attenuator Select	place the jitter attenuator on the receive side
LIC1.2	Jitter Attenuator Buffer Depth Select	128 bits
LIC1.1	Disable Jitter Attenuator	jitter attenuator enabled
LIC1.0	Transmit Power-Down normal	transmitter operation

LIC2.6	Line Interface Reset	No manual reset supported
LIC2.5	Insert BPV	No insert BPV supported
LIC2.2	Receive Composite Clock Filter Enable	Receive Composite Clock Filter Disabled
LIC2.1	Short Circuit Limit Disable (in E1 mode)	enable 50mA current limiter
LIC2.0	Custom Line Driver Select	normal operation
LIC3.7	CMI Enable	disable CMI mode
LIC3.6	CMI Invert	CMI normal at TTIP and RTIP
LIC3.4	Monitor Mode 1	Normal operation (no boost)
LIC3.3	Monitor Mode 0	Normal operation (no boost)
LIC3.0	Transmit Alternate Ones and Zeros	disabled
TLBC.6	Automatic Gain Control Enable	use Transmit AGC, TLBC bits 0-5 are "don't care"
TLBC.5	Gain Control Bit	Not used
TLBC.4	Gain Control Bit	Not used
TLBC.3	Gain Control Bit	Not used
TLBC.2	Gain Control Bit	Not used
TLBC.1	Gain Control Bit	Not used
TLBC.0	Gain Control Bit	Not used
TAF.7	International Bit	0
TAF.6	Frame Alignment Signal Bit (0)	0
TAF.5	Frame Alignment Signal Bit (0)	0
TAF.4	Frame Alignment Signal Bit (1)	1
TAF.3	Frame Alignment Signal Bit (1)	1
TAF.2	Frame Alignment Signal Bit (0)	0
TAF.1	Frame Alignment Signal Bit (1)	1
TAF.0	Frame Alignment Signal Bit (1)	1
TNAF.7	International Bit (Si)	0
TNAF.6	Frame Nonalignment Signal Bit (1)	1
TNAF.5	Remote Alarm (used to transmit the alarm A)	0
TNAF.4	Additional Bit 4 (Sa4)	0
TNAF.3	Additional Bit 5 (Sa5)	0
TNAF.2	Additional Bit 6 (Sa6)	0
TNAF.1	Additional Bit 7 (Sa7)	0
TNAF.0	Additional Bit 8 (Sa8)	0
TSiAF.0-7	Si Bit of Frames 0, 2, 4, 6, 8, 10, 12, 14	0 in all bit locations
TSiNAF.0-7	Si Bit of Frames 1, 3, 5, 7, 9, 11, 13, 15	0 in all bit locations
TRA.0-7	Remote Alarm Bit of Frame 1, 3, 5, 7, 9, 11, 13, 15	0 in all bit locations
TSa4.0-7	Sa4 Bit of Frames 1, 3, 5, 7, 9, 11, 13, 15	0 in all bit locations
TSa5.0-7	Sa5 Bit of Frames 1, 3, 5, 7, 9, 11, 13, 15	0 in all bit locations
TSa6.0-7	Sa6 Bit of Frames 1, 3, 5, 7, 9, 11, 13, 15	0 in all bit locations
Tsa7.0-7	Sa7 Bit of Frames 1, 3, 5, 7, 9, 11, 13, 15	0 in all bit locations
Tsa8.0-7	Sa8 Bit of Frames 1, 3, 5, 7, 9, 11, 13, 15	0 in all bit locations
TSACR.0-7	Insertion Control Bits for TsiAF, TSiNAF, TRA, TSa4, TSa5, TSa6, TSa7, TSa8	do not insert data from the registers TsiAF, TSiNAF, TRA, TSa4, TSa5, TSa6, TSa7, TSa8 into the transmit data stream

RFDL.0-5	BOC Bit 0-5	0 in all bit locations
TFDL.7	Transmit FDL Bit 7 MSB of the transmit FDL code	0
TFDL.6	Transmit FDL Bit 6	0
TFDL.5	Transmit FDL Bit 5	0
TFDL.4	Transmit FDL Bit 4	1
TFDL.3	Transmit FDL Bit 3	1
TFDL.2	Transmit FDL Bit 2	1
TFDL.1	Transmit FDL Bit 1	0
TFDL.0	Transmit FDL Bit 0 LSB of the transmit FDL code	0
RFDLM1.0-7	Receive FDL Match Bit 0-7	0 in all bit locations
RFDLM2.0-7	Receive FDL Match Bit 0-7	0 in all bit locations

Transmit PLL

In hardware-controller mode, the input to the TX PLL is always TCLK PIN. TX CLOCK is selected by the TCSS0 and TCSS1 pins. The PLL_OUT pin is always the same signal as select for TX CLOCK. If the user wants to slave the transmitter to the recovered clock, then the RCLK pin must be tied to the TCLK pin externally.

Table 4. Pin-Function Descriptions In Hardware Mode

Pin	Name	Type	Function
47	PLL_OUT	O	Transmit PLL Output. 1544kHz, 2048kHz, 64kHz, or 6312kHz output from the internal TX PLL
17	TCLK	I	Transmit Clock Input. A 64kHz, 1.544MHz, 2.048MHz, or 6312kHz primary clock. By using TCSS0 and TCSS1 pins, may be selected by the TX PLL mux to provide a clock to the transmit section
6331	TCSS0 TCSS1	I	Transmit Clock Source Select 0 and 1 Selects the output of the TX PLL Clock Mux function.
			TCSS1 TCSS0 Transmit Clock (TX Clock) Source
			0 0 The TCLK pin is the source of transmit clock
			0 1 The PLL_CLK is the source of transmit clock
			1 0 The scaled signal at MCLK as the transmit clock
1 1 The signal present at RCLK is the transmit clock			

Transmit Side

Pin	Name	Type	Function
21	TSER	I	Transmit Serial Data. Source of transmit data sampled on the falling edge of the selected transmit clock. In normal operation the selected transmit clock is output at the TCLKO pin.
23	TS_8K_4	I	TSYNC, 8kHz Sync, 400Hz Sync (400Hz Sync N/A in HW mode.)T1/E1 Mode: A pulse at this pin will establish either frame or multiframe boundaries for the transmit side. 64KCC Mode: Establishes the boundary for the 8kHz portion of the composite clock.
18	TCLKO	O	Transmit Clock Output. In normal operation this output is the selected transmit clock from the TX_PLL, TCLK pin, or the recovered clock (RCLK). When remote loopback is enabled this pin will output the recovered network clock.
20	TPOSO	O	Transmit Positive-Data Output. In T1 or E1 mode, updated on the rising edge of TCLKO with the bipolar data out of the transmit-side formatter. In 64KCC or 6312 mode, this pin will be low.
19	TNEGO	O	Transmit Negative-Data Output. In T1 or E1 mode, updated on the rising edge of TCLKO with the bipolar data out of the transmit-side formatter. In 64KCC or 6312 mode, this pin will be low.

Receive Side

Pin	Name	Type	Function
25	RCLK	O	Receive Clock. Recovered 1.544MHz (T1), 2.048MHz (E1), 6312kHz (G.703 Synchronization Interface), or 64kHz (composite clock) clock.
26	RS_8K	O	Receive Sync/ 8kHz Clock. T1/E1 Mode: An extracted pulse, one RCLK wide, is output at this pin that identifies either frame (RSM pin = 0) or multiframe (RSM pin = 1) boundaries. 64KCC Mode: This pin will output the extracted 8kHz portion of the composite clock signal. 6312K Mode: This pin will be in a high-impedance state.
27	400HZ	O	400HZ Clock OutputT1/E1 Mode: This pin will be in a high-impedance state.64KCC Mode: This pin will output the 400Hz clock if enabled.6312K Mode: This pin will be in a high-impedance state.
28	RSER	O	Receive Serial DataT1/E1 Mode: This is the received NRZ serial data updated on rising edges of RCLK. 64KCC Mode: This pin will be in a high-impedance state.6312K Mode: This pin will be in a high-impedance state.
30	RLOF_CCE	O	Receive Loss of Frame or Composite Clock Error T1/E1 Mode: Set when the receive synchronizer is searching for frame alignment (RLOF mode). 64KCC Mode: Active high when errors are detected in the 8kHz clock or 400Hz clock6312K Mode: This pin will be in a high-impedance state.
32	RLOS	O	Receive Loss of SignalT1 Mode: High when 192 consecutive zeros detected.E1 Mode: High when 255 consecutive zeros detected.64KCC Mode: High when consecutive zeros detected for 130ms typically.6312K Mode: High when consecutive zeros detected for 65ms typically.
29	RAIS	O	Receive Alarm Indication SignalT1 Mode: Will toggle high when receive Blue Alarm is detected.E1 Mode: Will toggle high when receive AIS is detected.64KCC Mode: This pin will be in a high-impedance state.6312K Mode: This pin will be in a high-impedance state.

Controller Interface

Pin	Name	Type	Function
46	JACKS	I	JA Clock Source SelectJA Clock Select. Set this pin high for T1 mode operation when either a 2.048MHz, 4.096MHz, 8.192MHz or 16.382MHz signal is applied at MCLK.
14	TMODE0	I	Transmit Mode Select 0, 1, 2, 3. Used to configure the transmit-operating mode. See Transmit Path Operating Mode below:
49	TMODE1		
48	TMODE2		
62	TMODE3		

Transmit-Path Operating Mode

Tmode3 Pin 62	Tmode2 Pin 48	Tmode1 Pin 49	Tmode0 Pin 14	Transmit-Path Operating Mode
0	0	0	0	T1 D4
0	0	0	1	T1 ESF
0	0	1	0	J1 D4
0	0	1	1	J1 ESF
0	1	0	0	E1 FAS
0	1	0	0	E1 FAS + CAS (Note 1)
0	1	0	1	Reserved
0	1	1	0	E1 CRC4
0	1	1	0	E1 CRC4 + CAS (Note 1)
0	1	1	1	Reserved
1	0	0	0	E1 G.703 2048kHz Synchronization Interface
1	0	0	1	64kHz + 8kHz Synchronization Interface
1	0	1	0	64kHz + 8kHz + 400Hz Synchronization Interface
1	0	1	1	6312kHz Synchronization Interface
1	1	0	0	Reserved
1	1	0	1	Reserved
1	1	1	0	Reserved
1	1	1	1	Reserved

Note 1: The DS26502 does not have an internal source for CAS signaling and multiframe alignment generation. CAS signaling, and the multiframe alignment word, must be embedded in the transmit data (in the TS16 position) present on the TSER pin and frame aligned to sync signal on the TS_8K_4 pin.

Pin	Name	Type	Function
39	TSTRST	I	Tri-State Control and Device Reset. TSTRST high tri-states all output and I/O pins. Set low for normal operation. Useful for in-board level testing.
57 59	BIS0 BIS1	I	Bus Interface Mode Select 1, 0. These bits select the controller interface mode of operation. BIS0 = 1 and BIS1 = 1 selects Hardware Mode
6	RITD	I	Receive Internal Termination DisableThe internal receive termination value is dependent on the state of the RMODEx pins. 0 = Enable the internal receive termination. 1 = Disable the internal receive termination.
5	TITD	I	Transmit Internal Termination DisableThe internal transmit termination value is dependent on the state of the TMODEx pins. 0 = Enable the internal transmit termination. 1 = Disable the internal transmit termination.
34 61 64	RMODE0 RMODE1 RMODE2 RMODE3	I	Receive Mode Select 0, 1, 2, 3. Used to configure the receiver-operating mode. See Receive Path Operating Mode below:

Receive Path Operating Mode

Rmode3 Pin 64	Rmode2 Pin 61	Rmode1 Pin 4	Rmode0 Pin 3	Receive Path Operating Mode
0	0	0	0	T1 D4
0	0	0	1	T1 ESF
0	0	1	0	J1 D4
0	0	1	1	J1 ESF
0	1	0	0	E1 FAS
0	1	0	1	E1 CAS
0	1	1	0	E1 CRC4
0	1	1	1	E1 CAS and CRC4
1	0	0	0	E1 G.703 2048kHz Synchronization Interface
1	0	0	1	64kHz + 8kHz Synchronization Interface
1	0	1	0	64kHz + 8kHz + 400Hz Synchronization Interface
1	0	1	1	6312kHz Synchronization Interface
1	1	0	0	Reserved
1	1	0	1	Reserved
1	1	1	0	Reserved
1	1	1	1	Reserved

Pin	Name	Type	Function
2	TSM	I	TS_8K_4 Mode Select In T1 or E1 operation, selects frame or multiframe mode for the TS_8K_4 pin. 0 = Frame Mode. 1 = Multiframe Mode.
1	RSM	I	RS_8K Mode Select Selects frame or multiframe pulse at RS_8K pin. 0 = Frame Mode. 1 = Multiframe Mode.
15 16	MPS0 MPS1	I	MCLK Prescaler Select 0 and 1 Sets the prescale value for the PLL. T1 Mode MCLK (MHz) MPS1 MPS0 JACKS 1.544 0 0 0 3.088 0 1 0 6.176 1 0 0 12.352 1 1 0 2.048 0 0 1 4.096 0 1 1 8.192 1 0 1 16.384 1 1 1 E1 Mode MCLK (MHz) MPS1 MPS0 JACKS 2.048 0 0 0 4.096 0 1 0 8.192 1 0 0 16.384 1 1 0
10	TAIS	I	Transmit AIS In T1/E1 operating modes, the transmitter will transmit an AIS pattern when high. This pin is ignored in all other operating modes. 0 = Normal Transmission. 1 = Transmit AIS Alarm.

9	E1TS	I	E1 Termination Select Selects the E1 internal termination value at both the transmitter and receiver. This pin is ignored in all other operating modes. 0 = 120Ω termination 1 = 75Ω termination
55	HBE	I	Transmit and Receive B8ZS/HDB3 Enable Enables transmit and receive B8ZS/HDB3 when in T1/E1 operating modes. 0 = HDB3/B8ZS disabled 1 = HDB3/B8ZS enabled
60	RLB	I	Remote Loopback Enable In this loopback, data received at RTIP and RRING will be looped back to the transmit LIU. Received data will continue to pass through the receive-side framer of the DS26502 as it would normally, and the data from the transmit side formatter will be ignored. This function is only valid when the transmit side and receive side are in the same operating mode. 0 = Remote Loopback disabled 1 = Remote Loopback enabled
11 12 13	L0 L1 L2	I	Line Build-Out Select 0, 1, 2. Selects the line build-out value. For E1 see E1 Line Build-Out below: For T1 see T1 Line Build Out below:

E1 Line Build-Out

L2 PIN 13	L1 PIN 12	LO PIN 11	Application	N (1)	Return Loss	Rt (1)
0	0	0	75Ω normal	1:2	N.M. (2)	0
0	0	1	120Ω normal	1:2	N.M. (2)	0
1	0	0	75Ω with high return loss (1)	1:2	21dB	6.2Ω
1	0	1	120Ω with high return loss (1)	1:2	21dB	11.6Ω
1	1	0	Reserved	—	—	—
1	1	1	Reserved	—	—	—

T1 Line Build-Out

L2 PIN 13	L1 PIN 12	LO PIN 11	Application	N (1)	Return Loss	Rt (1)
0	0	0	DSX-1 (0 to 133 feet)/0dB CSU	1:2	N.M.	0
0	0	1	DSX-1 (133 to 266 feet)	1:2	N.M.	0
0	1	0	DSX-1 (266 to 399 feet)	1:2	N.M.	0
0	1	1	DSX-1 (399 to 533 feet)	1:2	N.M.	0
1	0	0	DSX-1 (533 to 655 feet)	1:2	N.M.	0
1	0	1	Reserved	—	—	—
1	1	0	Reserved	—	—	—
1	1	1	Reserved	—	—	—

Note 1: TTD pin must be connected high in this mode.

Note 2: N.M. = not meaningful.

JTAG

Pin	Name	Type	Function
34	JTCLK	I	JTAG Clock. This clock input is typically a low-frequency (less than 10MHz), 50% duty-cycle clock signal.
33	JTMS	I	JTAG Mode Select (with Pullup). This input signal is used to control the JTAG controller state machine and is sampled on the rising edge of JTCLK.
36	JTDI	I	JTAG Data Input (with Pullup). This input signal is used to input data into the register that is enabled by the JTAG controller state machine and is sampled on the rising edge of JTCLK.
37	JTDO	O	JTAG Data Output. This output signal is the output of an internal scan-shift register enabled by the JTAG controller state machine, and is updated on the falling edge of JTCLK. The pin is in the high-impedance mode when a register is not selected or when the JTRST signal is high. The pin goes into and exits the high impedance mode after the falling edge of JTCLK
35	JTRST	I	JTAG Reset (Active Low). This input forces the JTAG controller logic into the reset state and forces the JTDO pin into high impedance when low. This pin should be low while power is applied and set high after the power is stable. The pin can be driven high or low for normal operation, but must be high for JTAG operation.

Line Interface

Pin	Name	Type	Function
44	MCLK	I	Master Clock Input. A (50ppm) clock source. This clock is used internally for both clock/data recovery and for the jitter attenuator for both T1 and E1 modes. The clock rate can be 16.384MHz, 8.192MHz, 4.096MHz, or 2.048MHz. When using the DS26502 in T1-only operation, a 1.544MHz (50ppm) clock source can be used.
41	RTIP	I	Receive Tip. Analog input for clock recovery circuitry. This pin connects through a 1:1 transformer to the network. See the Line Interface Unit section of the DS26502 data sheet for details.
42	RRING	I	Receive Ring. Analog input for clock recovery circuitry. This pin connects through a 1:1 transformer to the network. See the Line Interface Unit section of the DS26502 data sheet for details.
51	TTIP	O	Transmit Tip. Analog line-driver output. This pin connects through a 1:2 step-up transformer to the network. See the Line Interface Unit section of the DS26502 data sheet for details.
54	TRING	O	Transmit Ring. Analog line-driver output. This pin connects through a 1:2 step-up transformer to the network. See the Line Interface Unit section of the DS26502 data sheet for details.
50	THZE	I	Transmit High-Impedance Enable. When high, TTIP and TRING will be placed into a high-impedance state.

Power

Pin	Name	Type	Function
7,24,58	DVDD	—	Digital Positive Supply. 3.3V, $\pm 5\%$. Should be tied to the RVDD and TVDD pins.
38	RVDD	—	Receive Analog Positive Supply. 3.3V, $\pm 5\%$. Should be tied to the DVDD and TVDD pins.
53	TVDD	—	Transmit Analog Positive Supply. 3.3V, $\pm 5\%$. Should be tied to the DVDD and RVDD pins.
8,22,56	DVSS	—	Digital Signal Ground. 0.0V. Should be tied to the RVSS and TVSS pins.
40,43,45	RVSS	—	Receive Analog Signal Ground. 0.0V. Should be tied to the DVSS and TVSS pins.
52	TVSS	—	Transmit Analog Signal Ground. 0.0V. Should be tied to the DVSS and RVSS pins.

Block Diagrams

The block diagrams below in Figures 1 through Figure 4 illustrate DS26502 functionality in hardware-controller mode.

These figures do not reference all DS26502 pins in hardware-controller mode, rather only the pins required to control the DS26502 functionality in hardware-controller mode. A complete description of pin functionality is provided in the Pin Function Description section of this application note. The following pins are not included in the block diagrams: RSM, TSM, TITD, RITD, E1TS, TAIS, LO, L1, L2, JACKS, HBE.

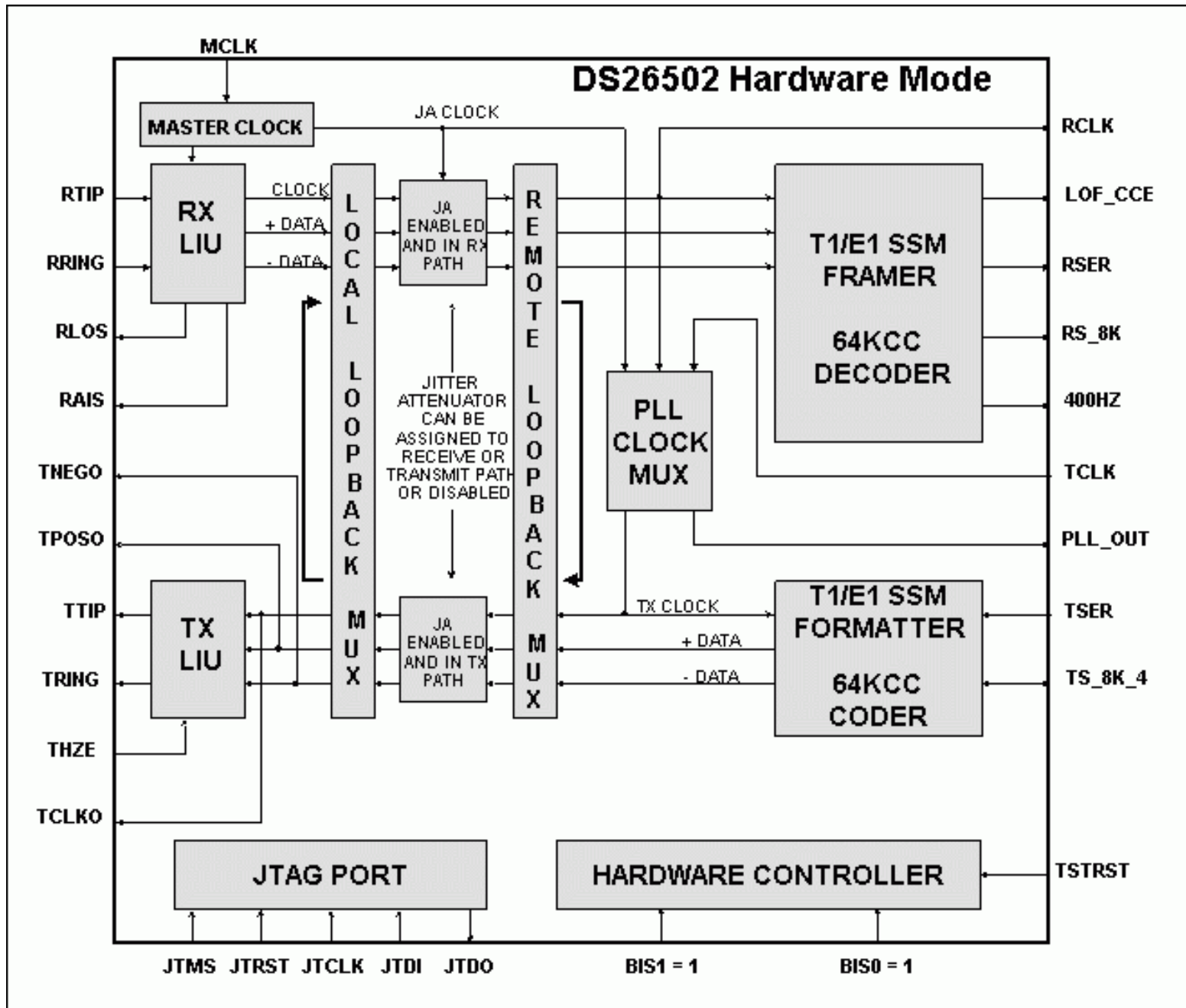

Figure 1. DS26502 Hardware-Mode Block Diagram

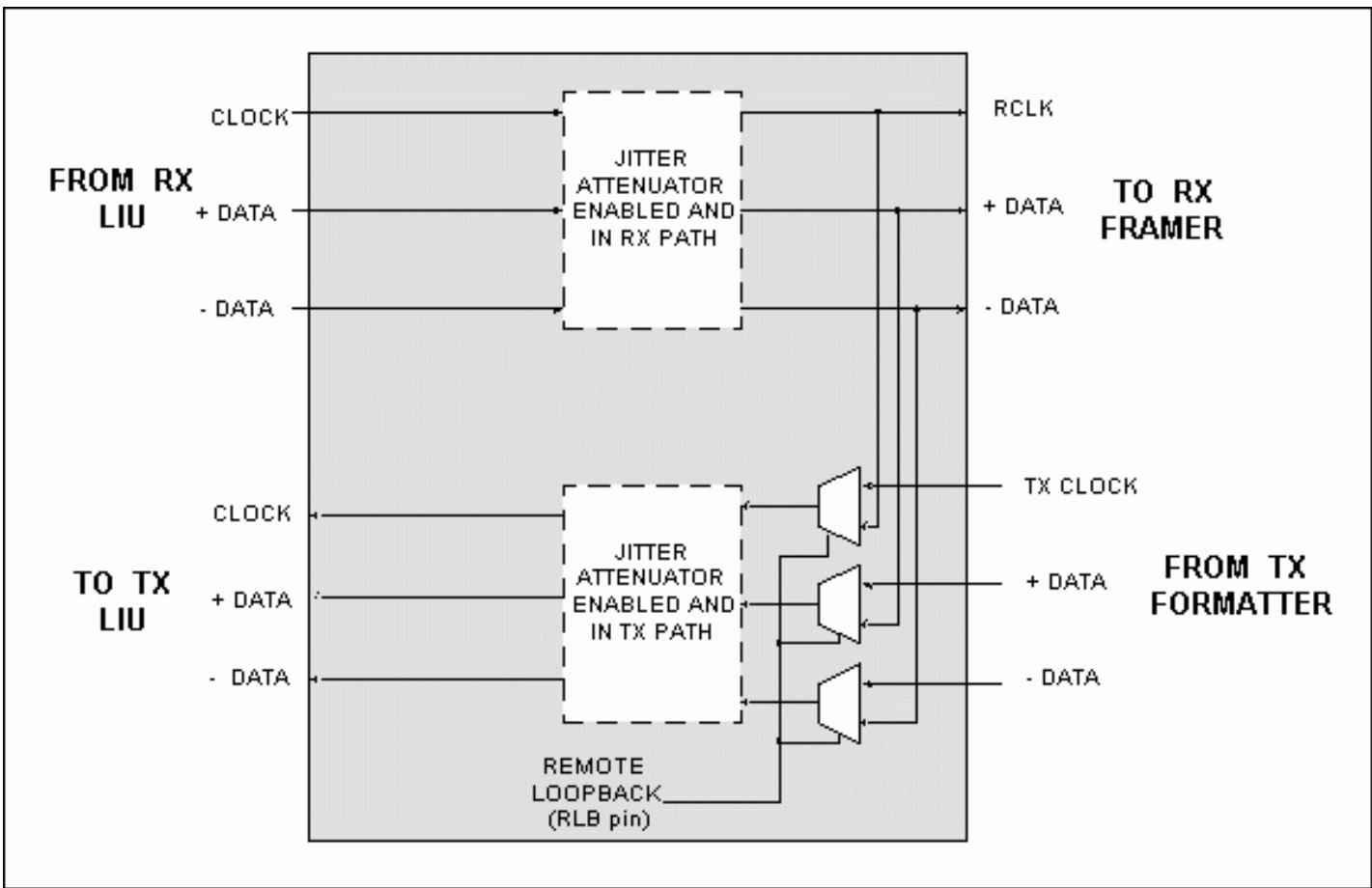

Figure 2. Loopback Mux Diagram

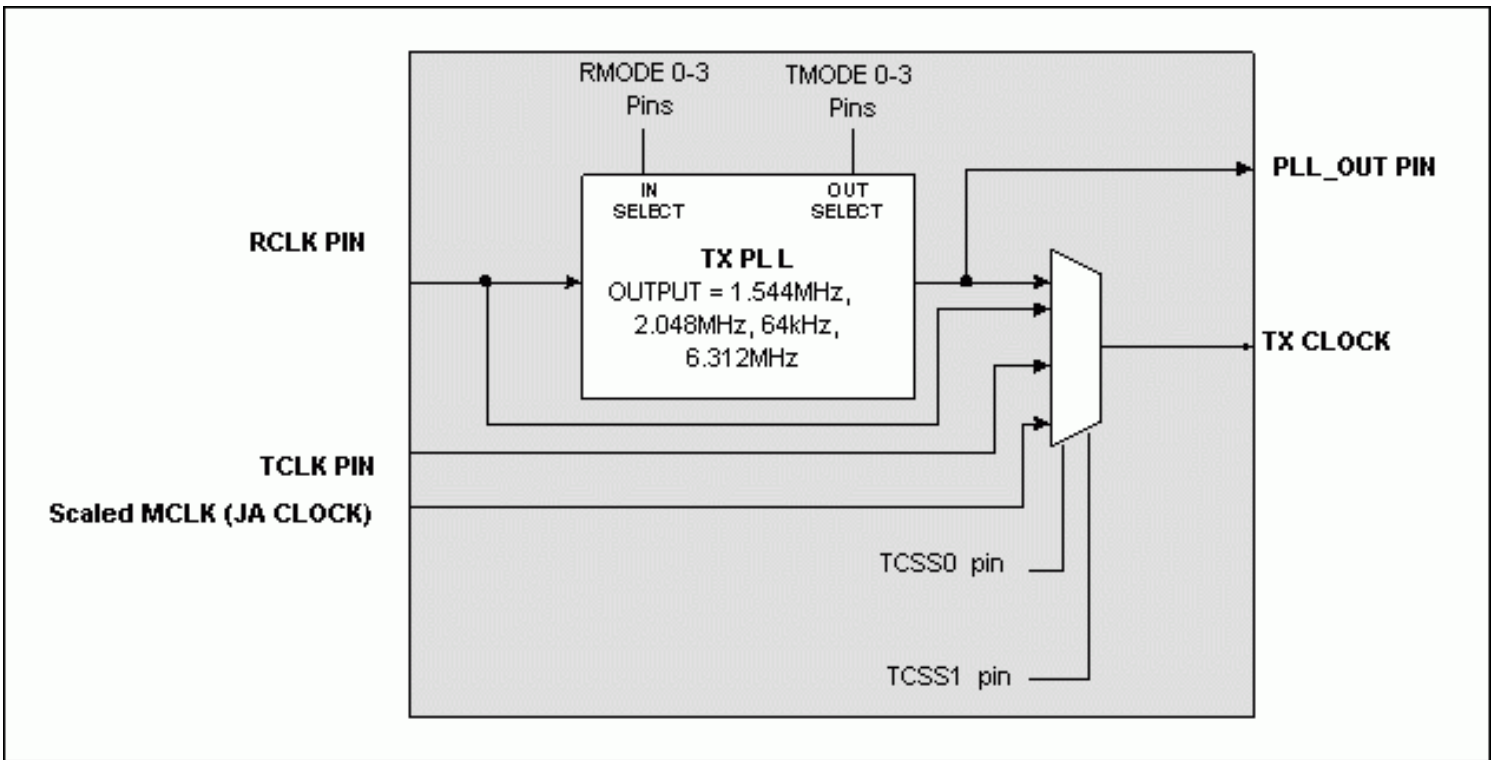

Figure 3. Transmit PLL Clock Mux Diagram

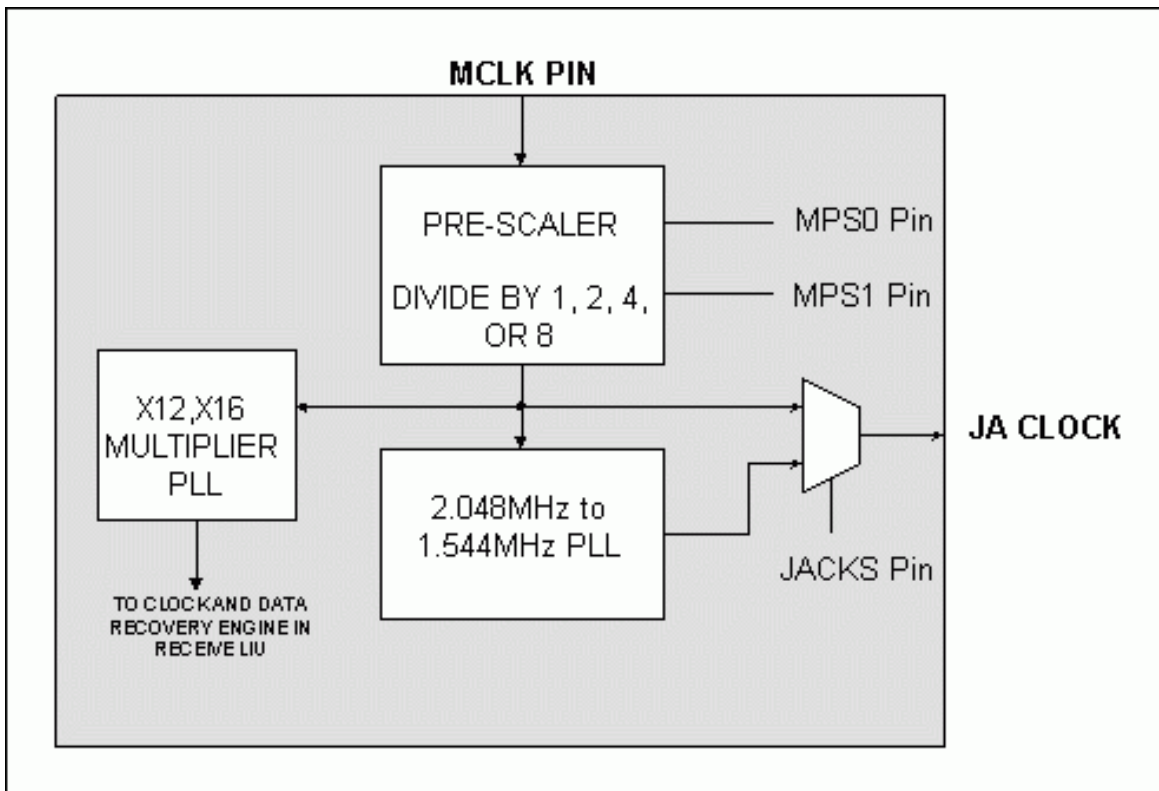

Figure 4. Master Clock PLL Diagram

DS26502 General Information

For more information about Dallas Semiconductor's communications products, please consult the data sheets available at [T/E Carrier and Packetized Communications](#).

If you have further questions concerning the operation of Dallas Semiconductor/Maxim devices, please contact the Telecommunication Applications support team by email at telecom.support@dalsemi.com, or call 972-371-6555.

Application Note 3422: <http://www.maxim-ic.com/an3422>

More Information

For technical questions and support: <http://www.maxim-ic.com/support>

For samples: <http://www.maxim-ic.com/samples>

Other questions and comments: <http://www.maxim-ic.com/contact>

Related Parts

DS26502: [QuickView](#) -- [Full \(PDF\) Data Sheet](#) -- [Free Samples](#)

AN3422, AN 3422, APP3422, Appnote3422, Appnote 3422

Copyright © by Maxim Integrated Products

Additional legal notices: <http://www.maxim-ic.com/legal>