

#### APPLICATION NOTE 3395

## Requirements of Remote Keyless Entry (RKE) Systems

*Remote keyless entry (RKE) has captivated automobile buyers, as evidenced by the popularity of RKE on new automobiles and as an after-market item. This application note provides an overview of RKE systems and discusses how they meet requirements such as range, battery life, reliability, cost, and regulatory compliance. It shows some circuits and design approaches and offers some predictions for future systems, which will include two-way communications.*

Remote keyless entry (RKE) systems have become extremely popular. The installation rate for RKE systems in new vehicles is more than 80% in North America and more than 70% in Europe. Besides the obvious advantages of convenience, RKE-actuated vehicle-immobilization technology minimizes car theft. European automakers are incorporating the technology in vehicles in cooperation with insurance companies, who in turn, require it as a condition for acquiring auto insurance. That trend began in Germany, and is expected to spread throughout Europe within a few years.

Most of these systems employ one-way (simplex) communications. But second- and third-generation systems may talk back to the key, telling you that the car needs gas or more pressure in the left front tire.

An RKE system consists of an RF transmitter in the keyfob (or key) that sends a short burst of digital data to a receiver in the vehicle, where it is decoded and made to open or close the vehicle doors or the trunk via receiver-controlled actuators. The wireless carrier frequency, is currently 315MHz in the US/Japan and 433.92MHz (ISM band) in Europe. In Japan the modulation is frequency-shift keying (FSK), but in most other parts of the world, amplitude-shift keying, or ASK is used. The carrier is amplitude modulated between two levels: To save power, the lower level is usually near zero, producing complete on-off keying (OOK).

### Detailed RKE Description and Design Objectives

Typical RKE systems (**Figure 1**) include a microcontroller in the key or keyfob. You unlock the car by pressing a pushbutton on the key that wakes up the microcontroller. The microcontroller sends a stream of 64 or 128 bits to the key's RF transmitter, where it modulates the carrier and is radiated through a simple printed-circuit loop antenna. (Though inefficient, a loop antenna fabricated as part of the PC board is inexpensive and widely used.)

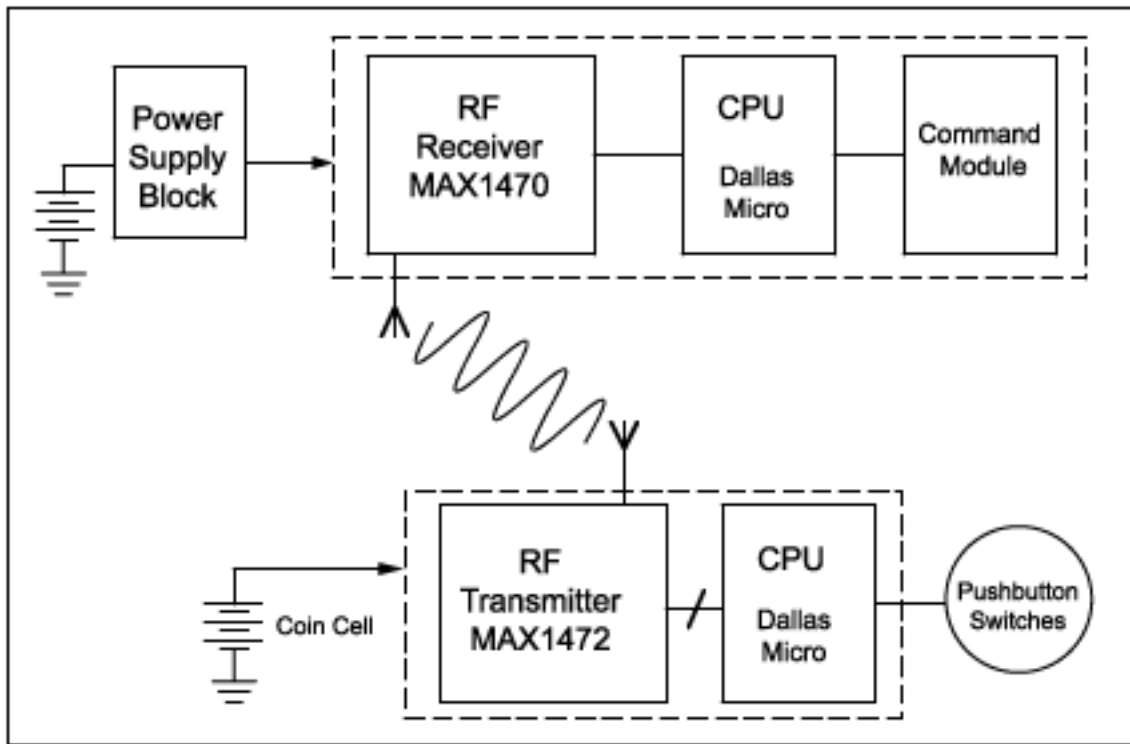

Figure 1. An RKE system consists of a keyfob circuit (lower diagram) transmitting to a receiver in the vehicle (upper diagram).

In the vehicle, an RF receiver captures that data and directs it to another microcontroller, which decodes the data and sends an appropriate message to start the engine or open the door. Multibutton keyfobs give the choice of opening the driver's door, or all doors, or the trunk, etc.

The digital data stream, transmitted between 2.4kbps and 20kbps, usually consists of a data preamble, a command code, some check bits, and a "rolling code" that ensures vehicle security by altering itself with each use. Without this rolling code, your transmitted signal might accidentally unlock another vehicle or fall into the hands of a car thief who could use it to gain entry later.

Several major objectives govern the design of these RKE systems. Like all mass-produced automotive components, they must offer low cost and high reliability. They should minimize power drain in both transmitter and receiver, because replacing batteries in a keyfob is a nuisance and recharging the car battery is a major nuisance. In addition to these requirements, the RKE system designer must juggle receiver sensitivity, carrier tolerance, and other technical parameters to achieve maximum transmission range within the constraints imposed by low cost and minimum supply current.

Design constraints include those defined by local regulations for short-range devices, such as FCC regulations in the US. While the use of short-range devices does not require a license, the products themselves are governed by laws and regulations that vary from country to country. For the US, the relevant document is the Code of Federal Regulations (CFR), Title 47, Part 15, which includes the 260MHz to 470MHz band (Section 15.231) and the 902MHz to 928MHz band (Section 15.249). (See [http://www.access.gpo.gov/nara/cfr/waisidx\\_01/47cfr15\\_01.html](http://www.access.gpo.gov/nara/cfr/waisidx_01/47cfr15_01.html)).

Here are some examples of how FCC regulations impose limits on an RKE design.

- Section 15.231 allows the device to transmit command or control signals, ID codes, and radio-control signals during emergencies, but not voice or video, toy-control signals, or continuous data.
- Transmission times must not exceed five seconds, and periodic transmissions of one second (max) at regular intervals are allowed only if the rate of such transmissions is less than one per hour.
- Maximum field strength at three meters from the transmit antenna shall be linearly proportional to the

fundamental frequency (260-470MHz), giving a range of 3750 $\mu$ V/m to 12500 $\mu$ V/m.

- Bandwidths at points 20dB down from the carrier shall not exceed 0.25% of the center frequency, and spurious emissions shall be attenuated by 20dB of the fundamental.

The following sections explore some of the issues associated with RKE system design, beginning with generation of the carrier frequency.

## Carrier Generation

First-generation RKE circuitry included surface acoustic-wave (SAW) devices for generating an RF carrier in the transmitter and a local-oscillator (LO) frequency in the receiver. Unfortunately, the initial frequency uncertainty of a typical SAW device is at least  $\pm 100$ kHz, and its frequency stability vs. temperature is relatively poor. At the receiver, an IF bandpass wide enough to admit the carrier also admits excessive noise, which in turn limits the range at which the vehicle can respond to a keyfob signal.

A current alternative to SAW devices is the crystal-based phase-locked loop, or PLL. The transition to PLLs is encouraged by increasingly strict regulation of RF emissions, especially in Europe and Japan. A crystal-based PLL transmitter costs a bit more than SAW resonators, but is typically ten times more accurate. The receiver can therefore have a narrower IF bandwidth, which in turn extends the transmission distance by raising the S/N ratio.

Earlier SAW devices positioned their nominal frequency at the midpoint of the 1.74MHz-wide 433MHz band (433.05MHz to 434.79MHz) to ensure reliable operation over the expected process and temperature variations. Thus, the nominal carrier frequency for 433MHz applications is now 433.92MHz, and PLL crystals must be selected accordingly.

Modern receiver and transmitter chips integrate the PLL circuitry so one need only connect a suitable crystal between two terminals on the chip. (See Sidebar below, ICs for RKE.) The MAX1470 PLL, for instance, includes a divide-by-64 block and a 10.7MHz IF with low-side injection. (The chip can operate at 433.92MHz, but its image-rejection capability is optimized for 315MHz.) The required crystal frequency for 315MHz operation (in megahertz) is  $f_{XTAL} = (f_{RF} - 10.7) / 64 = 4.7547$ . You must select a crystal that is specified to oscillate at 315MHz when loaded with the 5pF capacitance presented by chip terminals XTAL1 and XTAL2. For details on how to trim the crystal frequency, see [Application Note 1017: How to Choose a Quartz Crystal Oscillator for the MAX1470 Superheterodyne Receiver](#).

## Power Conservation

Because battery life is so important in an RKE system, the system must use every way possible to minimize operating current and "on time." The voltage-controlled oscillator (VCO) in the receiver PLL offers a good example of this attention to detail. The receiver must check almost constantly to avoid missing a demand for entry to the vehicle. To save power the receiver attempts to shut down as often as possible, even during the brief intervals between checks.

A keyfob transmitter usually issues four 10ms data streams in succession (about 40ms total) to ensure that the receiver captures at least one of them. The receiver polls every 20ms, working to decode at least two data streams as a margin against timing errors and noise. It needs 0.75ms of decoding time (enough for 7 or 8 received bits) to determine whether the data is of interest.

In addition to decoding time, the polling operation must first allow time for the receiver circuits to "wake up" and stabilize. Most amplifier circuits can wake up quickly, but the VCO's crystal is an electromechanical component that requires time to begin oscillating and more time to stabilize at the desired frequency. Conventional superheterodyne receivers require 2ms to 5ms for that purpose. But the MAX1470 VCO does it in only 0.25ms, by supplying just enough power to maintain vibration in the crystal. Thus, the MAX1470 detects keyfob

transmissions by waking up for only 1ms (0.75ms for decoding plus 0.25ms for stabilizing) during every 20ms (**Figure 2**). The fast-wakeup MAX1470 also operates on 3.3V instead of 5V, for a net energy savings that extends battery life (compared to conventional superhet receivers) by a factor of four or five.

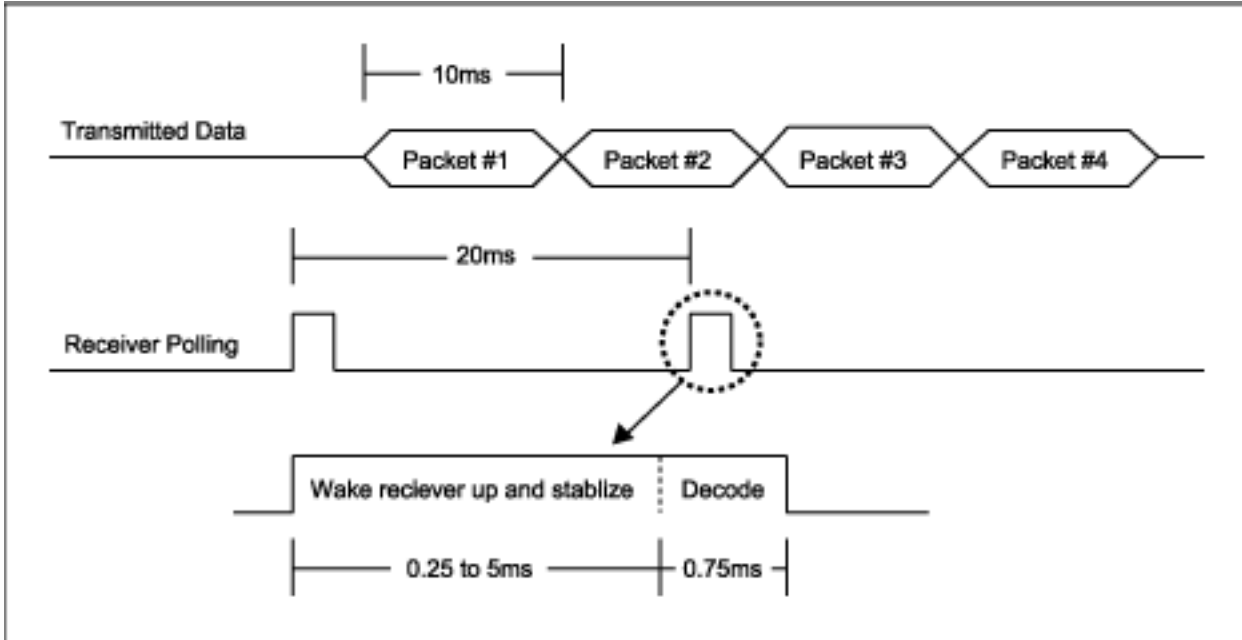

Figure 2. To monitor keyfob transmissions, an RKE receiver must allocate time to wake up and stabilize before decoding the incoming signal.

RKE is strictly a short-range technology, up to 20 meters, or 1 to 2 meters for passive RKE systems. Ensuring even a short transmission distance on low power and a low-cost design budget can be challenging for the RF circuitry. For simplicity, the transmit and receive antennas consist of a circular or rectangular loop of copper trace on a small PC board, with a simple LC network to match the antenna impedance to the transmit or receive chip. (See [Application Note 1830: How to Tune and Antenna Match the MAX1470 Circuit](#).)

## Add a Low-Noise Amplifier (LNA)?

The low transmit power imposed by FCC regulations, the small battery capacity, and the uncertainty in orientation of the transmit antenna demand maximum sensitivity at the RKE receiver chip. One way to enhance receiver sensitivity is to add an external low-noise amplifier (**Figure 3**), but the restriction in dynamic range associated with that approach may be unacceptable in your application. Consider the following analysis based on the MAX1470 superheterodyne receiver.

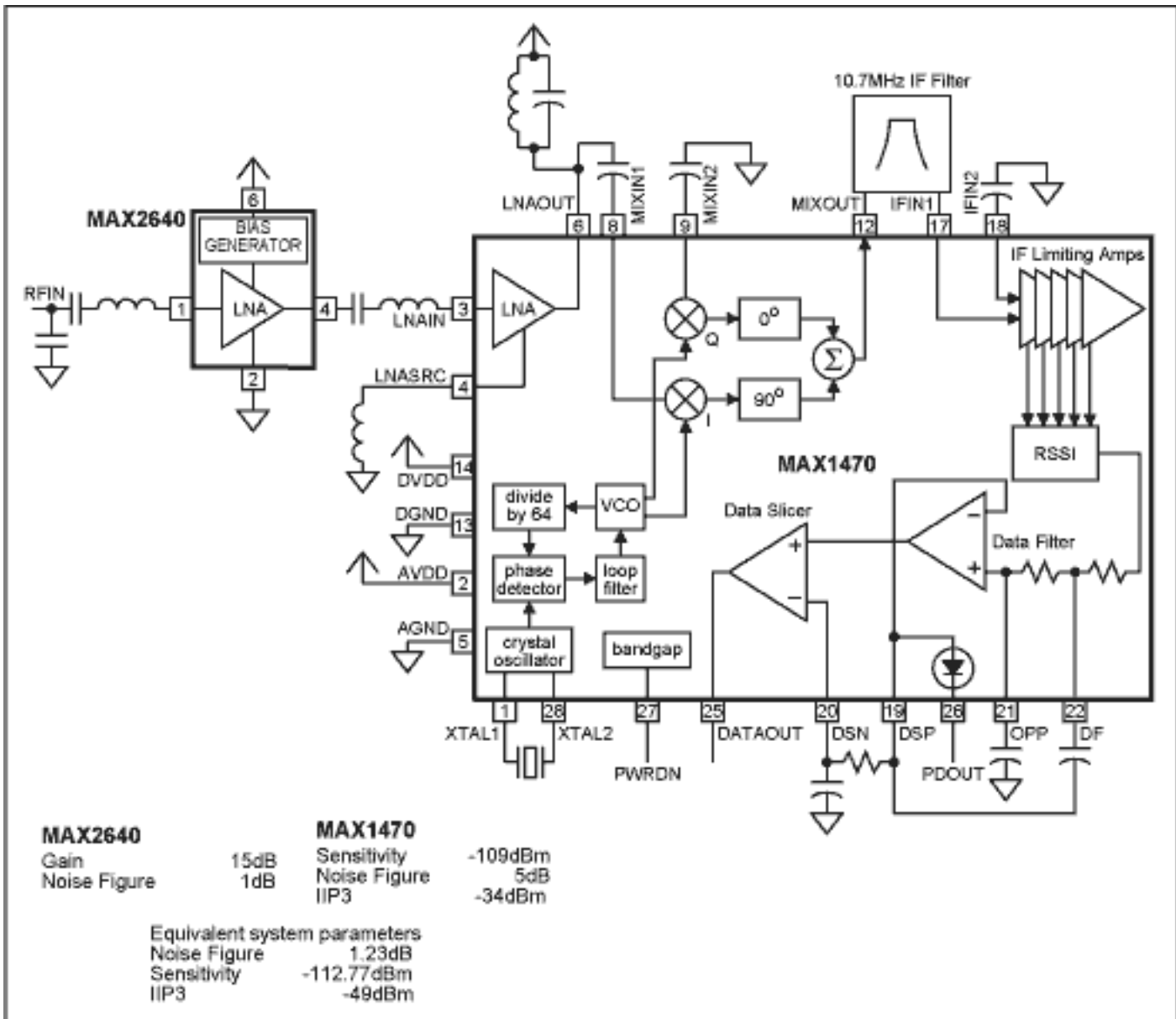

Figure 3. Adding an external LNA (the MAX2640) increases receiver sensitivity, but lowers the third-order intercept point.

A receiver's sensitivity depends on its noise figure, the minimum S/N ratio required for detection of the carrier modulation, and thermal noise in the system:

$$S = NF + n_0 + S/N, \quad \text{Equation 1}$$

where S is the minimum required signal level in dBm, NF is the receiver's noise figure in dBm,  $n_0$  is the receiver's thermal noise power in dBm, and S/N is the output signal-to-noise ratio in dBm required for adequate detection (usually based on the acceptable bit-error rate).

For simplicity we estimate S/N at 5dB, based on an assumption of Manchester-encoded data. By definition:

$$n_0 = 10 \log_{10}(kTB/1E-3),$$

where k is Boltzmann's constant ( $1.38E-23$ ), T is the temperature in degrees Kelvin, and B is the system noise

bandwidth. At room temperature ( $T = 290^{\circ}\text{K}$ ) over a 1Hz bandwidth,  $n_0 = -174\text{dBm/Hz}$ . Over a 300kHz IF bandwidth,  $n_0 = -119\text{dBm}$ .

Assuming the system sensitivity ( $S$ ) is  $-109\text{dBm}$ , use Equation 1 to calculate  $\text{NF} = 5\text{dB}$ . The relationship between noise figure ( $\text{NF}$ ) and noise factor ( $F$ ) is  $(\text{NF})_{\text{dB}} = 10\log F$ , where  $F = 10^{(\text{NF}_{\text{dB}}/10)}$ . Thus,  $F = 3.162$ . For a cascade of several 2-port devices, the noise factor is

$$F_{\text{Total}} = F_1 + (F_2 - 1)/G_1 + (F_3 - 1)/(G_1 * G_2) + \dots \quad \text{Equation 2}$$

Equation 2 lets you calculate the new noise factor after adding an external LNA to the system. For the MAX2640 LNA from Maxim,  $\text{NF} = 1\text{dB}$  and gain =  $15\text{dB}$  (i.e.,  $F_1 = 1.26$  and  $G_1 = 31.62$ ). Noise factor for the original system was  $3.162$ , so  $F_{\text{Total}} = 1.327$ , which is  $1.23\text{dB}$ . Substituting in Equation 1:

$$S = 1.23 - 119 + 5 = -112.77\text{dB}.$$

We assumed the original sensitivity was  $-109\text{dBm}$ , so we gained only  $3.77\text{dB}$  in that category. Now, note the effect on dynamic range as indicated by the third-order intercept point (IIP3). The MAX1470 has an internal LNA gain of  $16\text{dBm}$  and an internal mixer IIP3 of  $-18\text{dBm}$ , for an overall IIP3 of  $-34\text{dBm}$ . Adding the external LNA with its gain of  $15\text{dB}$  lowers this number to  $-49\text{dBm}$ . Thus, the addition of an external LNA improved sensitivity by almost  $4\text{dB}$ , but reduced the system dynamic range by  $15\text{dB}$ ! For a given application, you must decide whether such a trade-off is acceptable.

## Prognostications

The next development in RKE systems is 2-way (half-duplex) communications, which first appeared as the "passive RKE" already available in some high-end automobiles. With the key in your pocket, you simply walk up to the car, where a transmitter is continually polling to detect your arrival. When you come within range (one or two meters), the key and vehicle establish 2-way communications and open the door for you. Current 2-way systems include the usual acknowledgment functions (yes, door is locked), in addition to a remote-start function that allows the user to warm the car engine before leaving the house.

Future developments may also include the technology for tire-pressure sensing (TPS). Like passive RKE, TPS is available at this time only for some trucks and luxury automobiles. TPS systems have much in common with RKE. Circuitry very similar to that of an RKE keyfob resides in the valve stem of each tire, along with a sensor for tire pressure and temperature. Regular transmissions from each tire to a receiver in the vehicle (quite similar to an RKE receiver) then provide the driver with an early warning of any problem developing with the tires. TPS and RKE have so much in common (short range, simple modulation, need to conserve power, etc.), that future systems will probably save cost by sharing and consolidating circuit functions.

RKE may, or may not, evolve into a half-duplex system that informs the driver about the state of the car and its need for gas, oil, etc—all before the door is opened. It is more likely that RKE, if proven sufficiently robust and reliable, will eventually obsolete the key and its associated door hardware.

## CMOS ICs for RKE

Maxim is one of several manufacturers producing special-purpose integrated circuits for the RKE market. For the keyfob, it offers the world's smallest transmitter of its type—the 300MHz to 450MHz MAX1472, which comes in a tiny 3mm by 3mm, 8-pin SOT23 package. Its 2.1V to 3.6V supply voltage range enables the device to operate from a single lithium cell, drawing only 5nA of supply current in the standby mode.

During transmission of Manchester-encoded data, the MAX1472 supports data rates up to 100kbps and draws

between 3.0mA and 5.5mA of supply current while delivering -10dBm to +10dBm of power to a 50 $\Omega$  load. Its crystal-based phase-locked loop produces an accurate carrier frequency that enhances transmission range by allowing a tighter IF bandwidth in the receiver. To minimize power consumption, the internal oscillator starts quickly. It requires only 220 $\mu$ s startup time following an enable signal.

For vehicle receivers, consider the MAX1473 300MHz to 450MHz superhet ASK receiver. It offers -114dB sensitivity, and 50dB of RF image rejection in its fully differential internal mixer. The MAX1473 is optimized for either 315MHz or 433MHz operation. It operates on 3.3V or 5V and includes a low-noise amplifier (LNA), a crystal-based PLL for the local oscillator, and a 10.7MHz IF limiting amplifier with received signal-strength indicator (RSSI). An internal data filter and data slicer provide the digital data output. As an alternative, you can choose the MAX1470 receiver, which is similar to the MAX1473 but optimized only for 315MHz. It operates on a supply voltage of 3.0V to 3.6V.

---

Application Note 3395: <http://www.maxim-ic.com/an3395>

### More Information

For technical questions and support: <http://www.maxim-ic.com/support>

For samples: <http://www.maxim-ic.com/samples>

Other questions and comments: <http://www.maxim-ic.com/contact>

### Related Parts

MAX1470: [QuickView](#) -- [Full \(PDF\) Data Sheet](#) -- [Free Samples](#)

MAX1471: [QuickView](#) -- [Full \(PDF\) Data Sheet](#)

MAX1472: [QuickView](#) -- [Full \(PDF\) Data Sheet](#)

MAX1473: [QuickView](#) -- [Full \(PDF\) Data Sheet](#) -- [Free Samples](#)

MAX1479: [QuickView](#) -- [Full \(PDF\) Data Sheet](#) -- [Free Samples](#)

MAX7030: [QuickView](#) -- [Full \(PDF\) Data Sheet](#) -- [Free Samples](#)

MAX7031: [QuickView](#) -- [Full \(PDF\) Data Sheet](#) -- [Free Samples](#)

MAX7032: [QuickView](#) -- [Full \(PDF\) Data Sheet](#) -- [Free Samples](#)

MAX7033: [QuickView](#) -- [Full \(PDF\) Data Sheet](#) -- [Free Samples](#)

MAX7042: [QuickView](#) -- [Full \(PDF\) Data Sheet](#) -- [Free Samples](#)

MAX7044: [QuickView](#) -- [Full \(PDF\) Data Sheet](#)

AN3395, AN 3395, APP3395, Appnote3395, Appnote 3395

Copyright © 2005 by Maxim Integrated Products

Additional legal notices: <http://www.maxim-ic.com/legal>