

Application Note:

HFAN-3.2.0

Rev.1; 04/08

Improving Noise Rejection of a PIN-TIA ROSA



Maxim Integrated Products

Improving Noise Rejection of a PIN-TIA ROSA

For successful optical transceiver design, it is essential to maintain a good immunity between the Receiver Optical Sub-Assembly (ROSA) and external noise sources including the transmitter. This application note will address how the electronic elements should be positioned and assembled on a TO header by studying how the noise can be picked up by the components in the ROSA, with the goal of optimized noise rejection performance.

1 Example of ROSA Assembly

Figure 1 shows a top view of a Transistor Outline (TO) packaged PIN-TIA ROSA. A photodiode (PD-PIN in this case) is mounted on top of a chip capacitor (CFILT) whose bottom metal layer is connected to the TO header by conductive epoxy or eutectic. The active area of the photodiode is positioned on the TO axis. A transimpedance amplifier (TIA) is located on the TO header between two data output pins (OUT+ and OUT-). The TIA input is bonded to the anode contact of the photodiode by W2, while the photodiode is biased by bonding the TIA FILT pad to the top metal of the capacitor CFILT in W1, which is also the cathode contact of the photodiode. The ground pads and output pads are bonded to the TO header body and output pins by W5, W6 and W7 respectively. The TIA VCC pad is bonded to the VCC pin of the header by W3A. Another chip capacitor (CVCC) is connected to the VCC pin of the header by W4, performing as a part of the supply filter network.

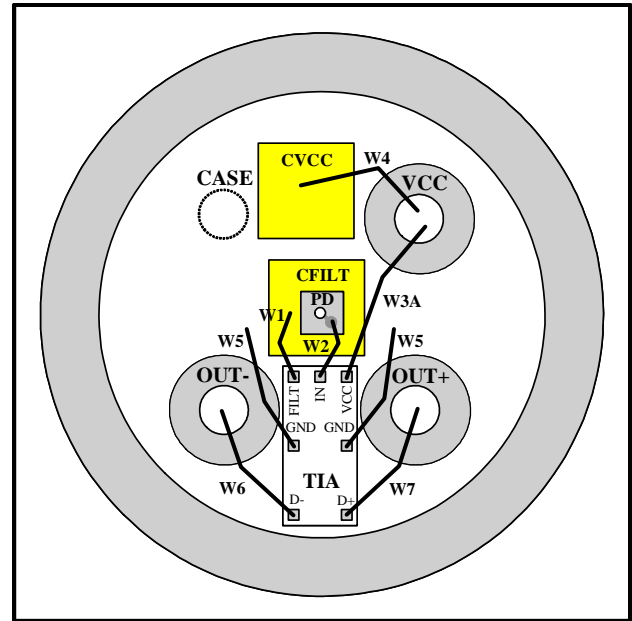

Figure 1: Top View of a PIN-TIA ROSA Assembly (example)

Figure 2 is a simplified equivalent circuit of the TIA and ROSA assembly. The parasitic inductance associated with the bond wires W_n is represented by L_n ($n = 1$ to 7). L3B will be addressed in the latter section of this application note. The interface of the ROSA to the external environment consists of the power supply pin (VCC), data output pins (OUT+ and OUT-), and the case pin (CASE) connected to circuit ground on module boards.

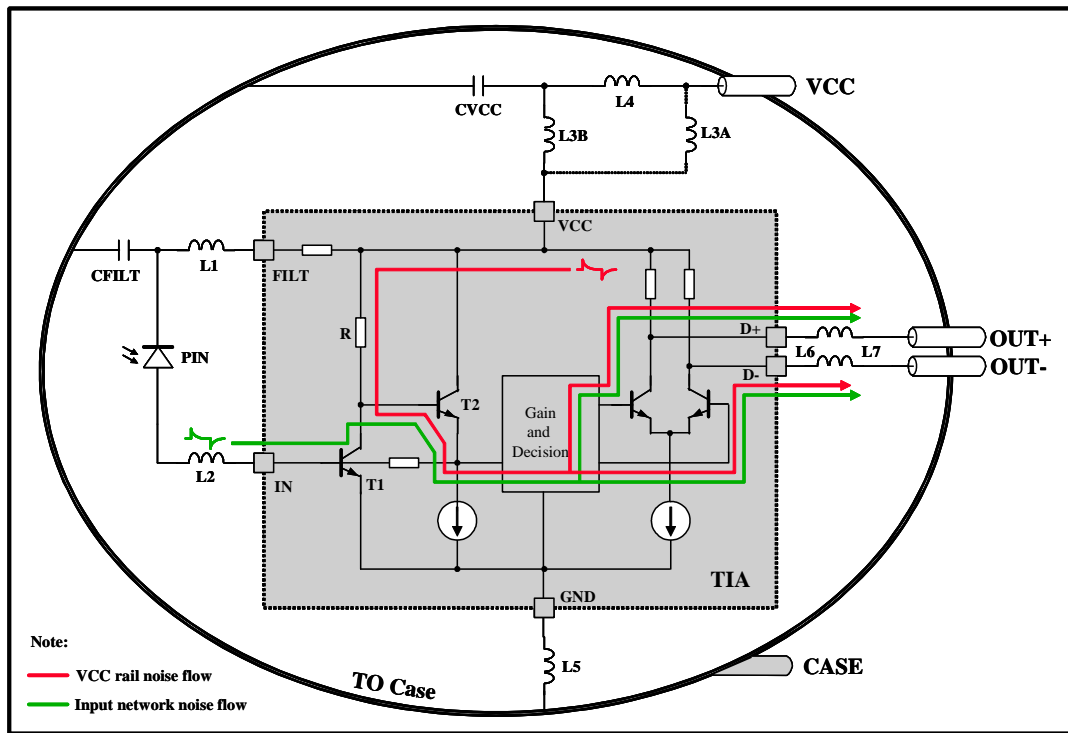

Figure 2: Simplified Equivalent Circuit of TIA and ROSA Assembly

2 Cause of the Noise and Performance Optimization

In general, the noise from external sources affects the ROSA output in two ways:

- A) Being coupled into the TIA input and amplified in the same way as the signal.

Noise picked up by the TIA input network, including the input bond wire (W2), the photodiode, and the filter capacitor structure, will be amplified by the TIA front-end transistors T1 and T2. Next, it will pass through the gain stage, and then the differential outputs in the same way as the signal carried by the photo current. This noise path is indicated in Figure 2 by “Input network noise flow”.

- B) Noise added to the TIA power supply rail will propagate through the amplifier chain, and be amplified.

Power supply noise is added to the base of the TIA front-end transistor (T2) through the biasing resistor (R), and to other gain stages in a similar way. It is delivered to the differential outputs as part of the total output signal.

There are two parameters used to evaluate the external noise influence on the ROSA performance: power supply noise rejection and common-mode to differential conversion.

2.1 Power Supply Noise Rejection

The VCC pin is one channel to bring the external noise into the ROSA. On one hand, the VCC noise can be coupled from the VCC bond wires (W4 and W3A), directly or indirectly, to the TIA input bond wire (W2). On the other hand, it can also be delivered to the power supply rail of the TIA through the VCC bond wires (L3A in this case). A ROSA with a better power supply noise rejection should show a smaller noise influence at its output for the same amount of noise at the VCC pin.

The following measures can be taken to optimize the power supply noise rejection performance:

A) Choose a right power supply filter network

Connecting the VCC pin of the TO header to the filter capacitor CVCC, then to the VCC pad of the TIA (as shown in Figure 3), proves more effective than connecting both the capacitor and TIA VCC pad to the VCC pin of the header (as in Figure 1). In this case, the bond wire W3A (L3A) is replaced by W3B (L3B), forming the L-C-L supply filter network shown in Figure 2.

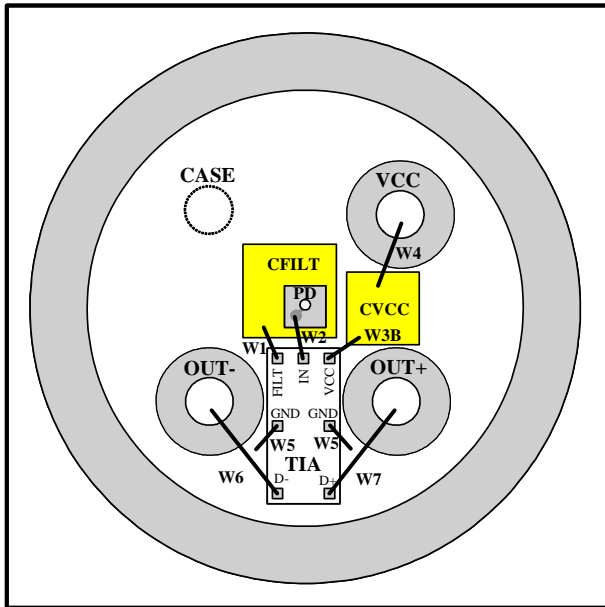

Figure 3: Top View of an improved ROSA Assembly

B) Minimize VCC pin noise radiation.

Minimizing the length of W4 will help reduce the noise coupling from the VCC pin to other TIA circuits. To do this, it is necessary to position the capacitor CVCC close to the VCC pin, to choose the landing point of W4 on the top of CVCC as close as possible to the VCC pin, and to minimize the loop length of the bond wire path. A capacitor with a good high-frequency performance is also important for power supply filtering.

C) Minimize the coupling to the TIA input.

Separating the VCC related bond wires (W3B and W4) from the TIA input bond wire (W2) and placing the sensitive bond wires in orthogonal directions are

critical to reduce crosstalk. It is easy to understand that the coupling between W3B and W2 in Figure 3 is much less than that between W3A and W2 in Figure 1.

The length of the TIA input bond wire (W2) should also be reduced by offsetting the filter capacitor (CFILT) relative to the center of the TO-header while still centering the active area of the photodiode. The length of the input bond wire (W2) should also be as short as possible.

D) Optimize the effectiveness of power supply filter network

The existence of the assembly inductance of the TIA power supply filter network (W3B) has strong influence on its effectiveness in terms of rejecting noise coupled in to the TIA power supply rail. It is critical to place the CVCC capacitor as close as possible to the VCC pad of the TIA, to choose a landing point of the bond wire close to the TIA, and to minimize the length of the bond wire. The assembly shown in Figure 3 should provide much better TIA power supply filtering than the assembly shown in Figure 1.

2.2 Common-Mode to Differential Conversion

External noise sources can also affect the ROSA performance through the output pins (OUT+ and OUT-). The noise carried on the output pins may be added to the power supply rail of the TIA. It can also be coupled, directly and indirectly, to the TIA input by the bond wires, amplified and delivered by the ROSA differential outputs. Here is a list of things that can be done to improve the noise added effect by common-mode to differential conversion:

A) Minimize the output pin radiation

Positioning the TIA correctly and minimizing the length of the output bond wires (W6 and W7) limit the direct radiation of the noise to the ROSA assembly.

B) Minimize the coupling to the TIA input

The noise on the output bond wires can be directly or indirectly coupled to the TIA input network. Try to separate the output bond wires (W6 and W7) from

the input bond wire (W2), and use the orthogonal approach when routing critical bond wires.

It is also important to take care of any indirect coupling from output to input. In Figure 1, the noise on output bond wires (W6 and W7) can be coupled to the ground bond wires (W5), and then further coupled to the TIA input bond wire (W2). Meanwhile, the noise coupled to the ground wires can be picked up by the TIA ground rail and applied to the base-emitter junction of T1, leading to an equivalent noise added effect to the TIA input. The solution is to route the ground bond wires (W5) orthogonal to output bond wires (W6 and W7), and to minimize their path length.

C) Optimize the effectiveness of power supply filter network

An effective power supply filter network will help reduce the noise added to the TIA power supply rail for minimum common-mode to differential conversion. Similar techniques described in the previous section can be used.

3 Conclusion

This application note has analyzed how external noise sources can affect the ROSA performance, and has provided a proposal for an improved ROSA assembly. It is important to place the ROSA elements at proper locations, to minimize the length of bond wires, and to reduce the coupling between critical bond wires. A ROSA built by following these rules will improve its immunity to external noise sources, including reduced transmitter-receiver crosstalk.