

APPLICATION NOTE 3356

MAX1917 Provides Pre-Bias Soft Start for Redundant Supply

Pre-bias soft start has become an important feature in redundant power supply systems, parallel power supply modules, battery back-up voltage buses, and other applications where multiple power sources supply one node. Specifically, pre-bias soft start ensures that no output capacitor discharging occurs during the soft start period of a dc/dc converter. Discharging the output capacitor could create either start up oscillation problems at cold start or large voltage disturbances on the output voltage bus at hot plug-in. Preventing output capacitor discharge has become a common requirement in point-of-load power supply designs.

[Pre-bias soft start](#) has become an important feature in redundant power supply systems, parallel power supply modules, battery back-up voltage buses, and other applications where multiple power sources supply one node. Specifically, pre-bias soft start ensures that no output capacitor discharging occurs during the [soft start](#) period of a dc/dc converter. Discharging the output capacitor could create either start up oscillation problems at cold start or large voltage disturbances on the output voltage bus at hot plug-in. Preventing output capacitor discharge has become a common requirement in point-of-load power supply designs.

MAX1917 was originally designed to meet termination voltage-tracking requirements demanded by double data rate (DDR) memory. To avoid large input inrush current in case a reference step voltage is applied to REFIN, the MAX1917 ramps up the output inductor current in 5 steps up to the preset output current limit threshold. By ramping inductor current directly, and not the feedback reference voltage, the output inductor current is always controlled to only source current to charge the output capacitor until the output voltage reaches its regulation value. Therefore no negative inductor current can be generated during soft start and consequently no discharge of the output capacitor takes place.

Although designed for DDR memory termination supplies, the MAX1917 is a good candidate for a point-of-load power supply controller due to its excellent transient response and small package size. **Figure 1** shows a schematic of the MAX1917 for a 2.5V point-of-load application. Table I lists the bill of materials. **Figure 2** shows soft start waveforms of both the output voltage and the output inductor current. It is evident from this figure that no discharging of the output voltage occurs during soft start, and the output inductor current is well maintained as a constant current source.

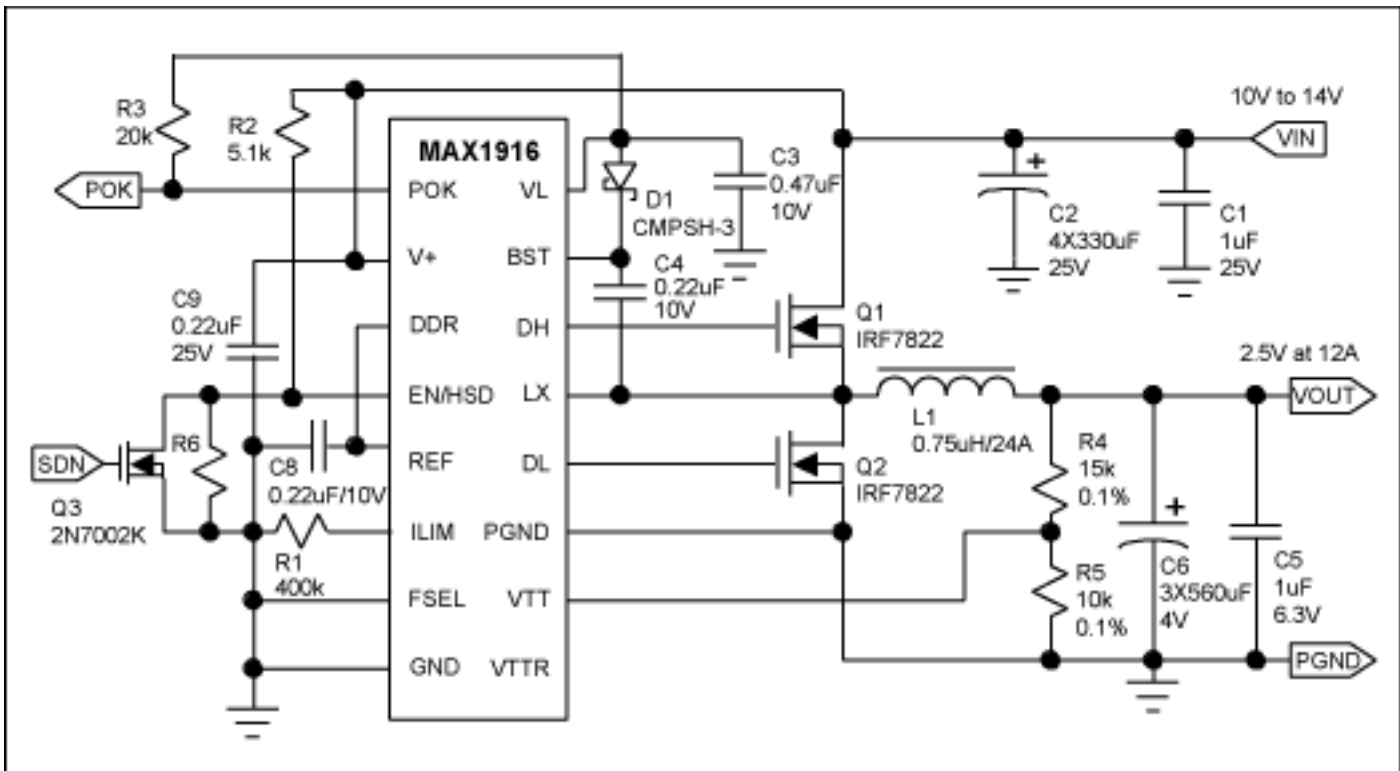

Figure 1. MAX1917 for 2.5V output power supply.

Table 1 Bill of Materials for 2.5V/15A application

Comp.	Description	Venders
C1	1.0uF/25V ceramic cap, TMK316BJ105ML, 20mW max esr.	Taiyo Yuden
C2	4X330uF/25V aluminum caps, ZA series, 26mW max esr.	Rubycon
C3	0.47uF/10V ceramic cap, EMK212BJ474MG, 20mW esr max.	Taiyo Yuden
C4, C8	0.22uF/10V ceramic capacitor, LMK107BJ224MA	Taiyo Yuden
C5	10uF/6.3V ceramic capacitor, JMK316BJ106ML, 20mW max esr.	Taiyo Yuden
C6	3X560uF, 4SP560M, 14mW max esr each capacitor.	Sanyo
C9	0.22uF/25V ceramic capacitor, TMK312BJ224MF	Taiyo Yuden
D1	30V/100mA Schottky diode, CMPSH-3	Central Semi.
L1	0.75uH/24A, CDEP149-OR7NC, (esr, 1.2mW max)	Sumida
Q1	IRF7822 IR	
Q2	2XIRF7822	IR
Q3	2N7002K	Siliconix
R1	400k, 1%	
R2	5.1k, 5%	
R3	20k, 5%	
R4	15k, 0.1%	
R5	10k, 0.1%	

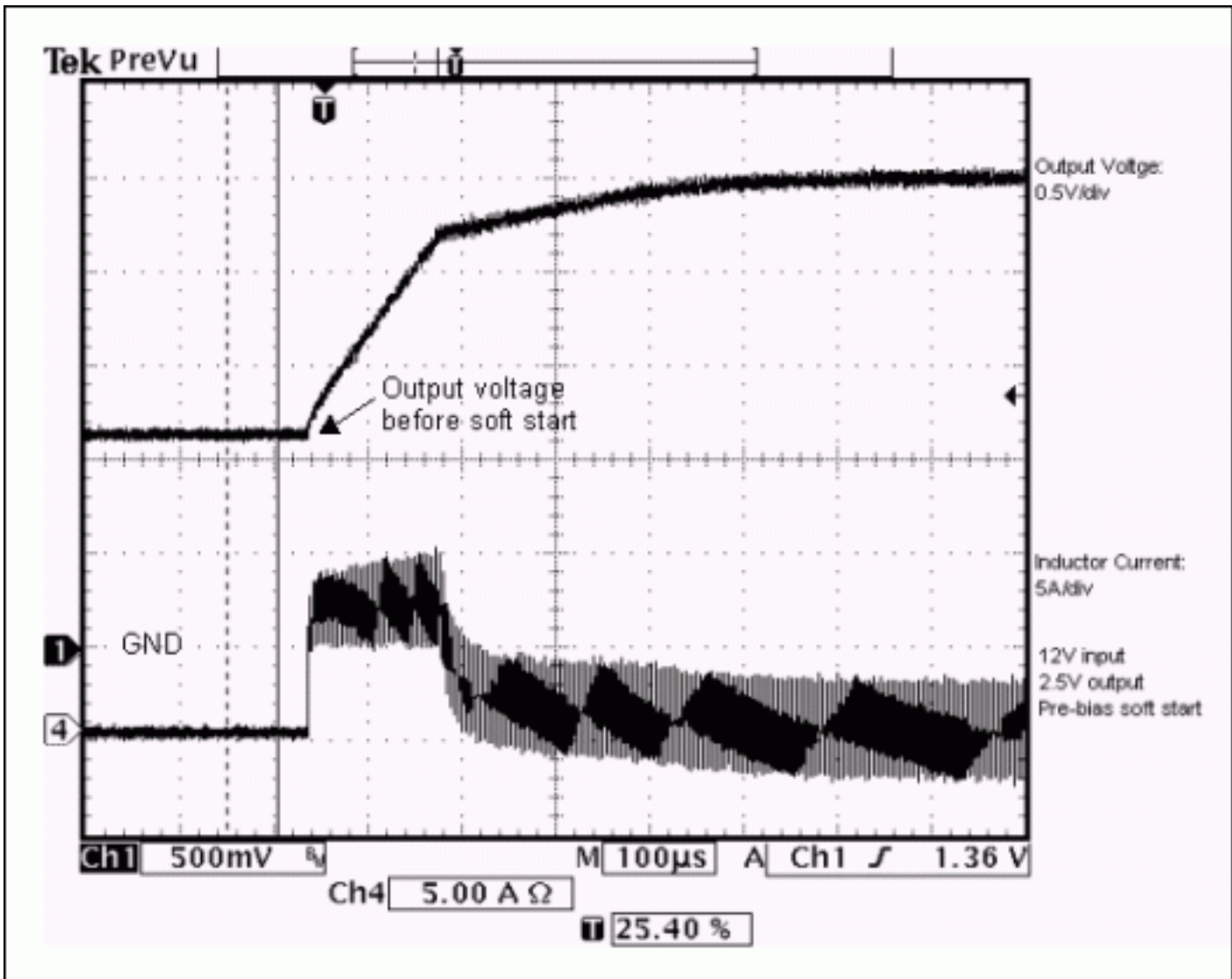

Figure 2. Pre-bias soft start waveforms of the MAX1917.

Application Note 3356: <http://www.maxim-ic.com/an3356>

More Information

For technical questions and support: <http://www.maxim-ic.com/support>

For samples: <http://www.maxim-ic.com/samples>

Other questions and comments: <http://www.maxim-ic.com/contact>

Related Parts

MAX1917: [QuickView](#) -- [Full \(PDF\) Data Sheet](#) -- [Free Samples](#)

AN3356, AN 3356, APP3356, Appnote3356, Appnote 3356

Copyright © 2005 by Maxim Integrated Products

Additional legal notices: <http://www.maxim-ic.com/legal>