



APPLICATION NOTE 3351

T3/E3/STS-1 Low Cost Repeater

Abstract: As telecom providers service more customers at higher speeds, they need larger network facilities, which require longer cable runs between systems. Interconnects often use copper cable for its price advantage, but problems arise as distance and data rate increase. Converting to fiber-optic based systems is costly. An alternative is to install repeaters, which are cost-effective and do not require replacing existing equipment. This application note describes a simple, low-cost repeater.

Introduction

Today's telecom providers service more customers at higher speeds than ever before. Larger network facilities require longer cable runs between systems. Since a majority of systems use copper cable for interconnects, problems arise when systems are separated by long distances. Longer copper cable runs can carry lower maximum data rates.

This shortcoming can be solved by either switching to fiber optic systems or installing repeaters on the existing cable interconnects. Conversion to fiber optics offers advantages but it is costly. Adding a repeater to the existing line is a simple, cost-effective solution which does not require replacement of existing equipment.

Design

When designing equipment for telecommunication use, it is good practice to adhere to some of the following guidelines. It is extremely important that the integrity of the interconnected high speed data signals is maintained for error free operation. The space inside a telecommunication facility is limited, so it is important that the equipment occupy no more space than necessary. Equipment that is easy to use and configure will reduce problems caused by user error. This repeater circuit was designed with all the above criteria in mind.

The main component of the repeater is the Maxim DS3150 T3/E3/STS-1 Line Interface Unit (LIU). This device performs all the functions necessary for interfacing at the physical layer to DS3, E3, and STS-1 lines. The receiver performs clock and data recovery, signal decoding, and loss-of-signal monitoring. The transmitter performs signal encoding and drives standard-compliant waveforms onto 75Ω coaxial cable. There is also a built in jitter attenuator that can be mapped into the receive or the transmit path. The remaining components are comprised of a single oscillator, passive devices, and an external or on board 3.3 volt power supply.

The diagram and table below list all of the components necessary to build the repeater circuit card excluding the power supply. The circuit is straight forward with two DS3150 devices being connected back to back between RPOS/RNEG/RCLK to TPOS/TNEG/TCLK. This allows for easy configuration and reduces the chance for an installation error. The available options are:

1. Remote loop back enable/disable
2. Operational mode selection T3/E3/STS-1
3. Transmission mode selection long haul/short haul

These options are selected by the switches on the card. The configuration option is for the oscillator which can either be one oscillator for single mode operation, or multiple oscillators for dual and triple mode operation. The remaining components are the magnetics for the line interface and the physical connectors for the transmit and

receive cables.

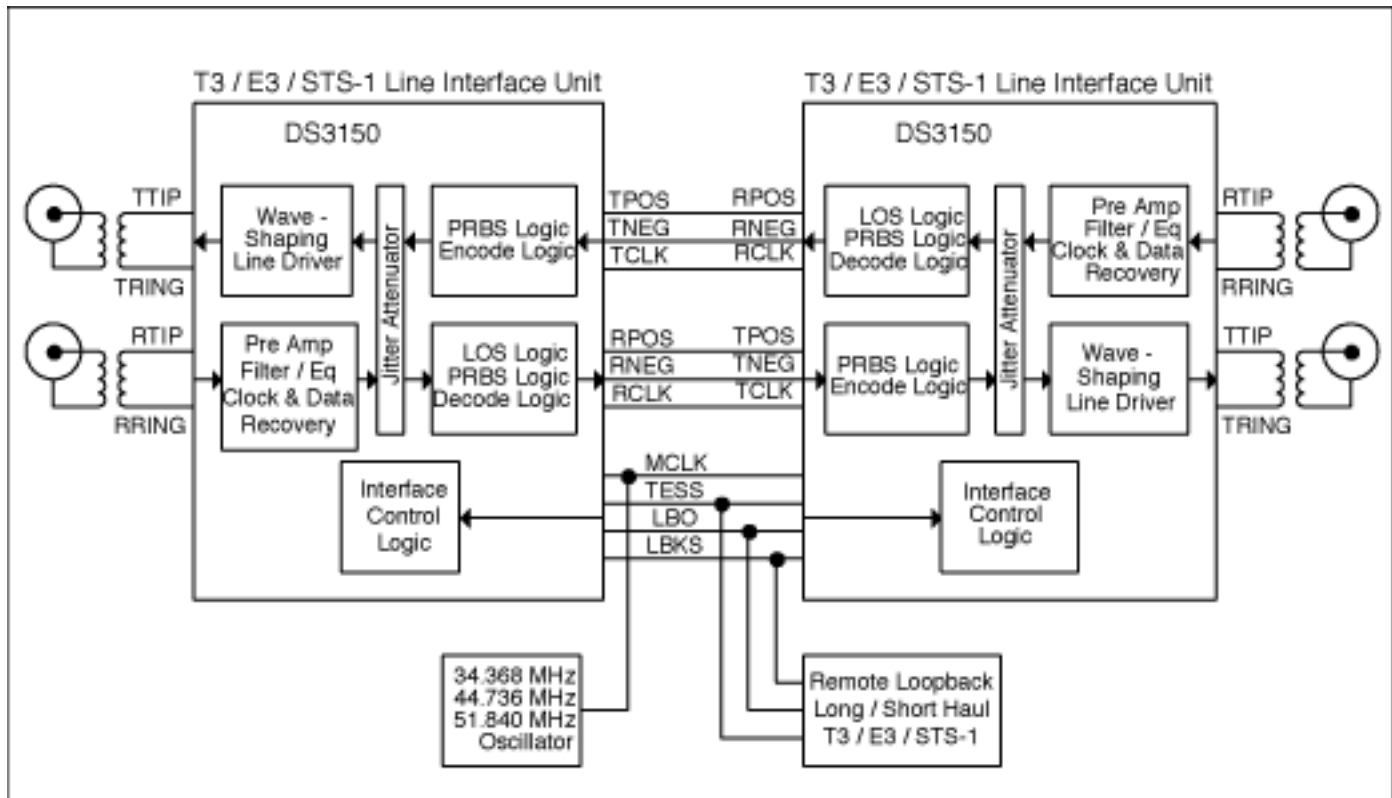

Figure 1. T3/E3/STS-1 Repeater block diagram.

Table 1. T3/E3/STS-1 Repeater Part Listing

Device	Part Count	Description	Vendor
DS3150	2	3.3 Volt DS3/E3/STS-1 Line Interface Unit	Maxim
PE-65968	4	6 Pin SMT 1:2CT Transformer	Pulse Engineering
NTH089AA3-34.2680	1	34.368MHz Oscillator 3.3 Volt	Saronix
NTH089AA3-44.7360		44.736MHz Oscillator 3.3 Volt	Saronix
NTH089AA3-51.8400		51.840MHz Oscillator 3.3 Volt	Saronix
BNC Plug	4		Various
DIP Switch	1		Various
Power Connector	1		Various
Resistor			Various
Capacitor			Various
LED	3	Power & LOS Indication	Various

References

For further questions on T3/E3/STS-1 Repeaters, please contact the Telecommunication Applications support team via email telecom.support@maxim-ic.com or telephone at 972-371-6555.

For more information about the DS3150, please consult the DS3150 data sheet available on the Maxim website at www.maxim-ic.com/telecom.

More Information

For technical support: www.maxim-ic.com/support

For samples: www.maxim-ic.com/samples

Other questions and comments: www.maxim-ic.com/contact

Automatic Updates

Would you like to be automatically notified when new application notes are published in your areas of interest?

[Sign up for EE-Mail™](#).

Related Parts

DS3150: [QuickView](#) -- [Full \(PDF\) Data Sheet](#) -- [Free Samples](#)

AN3351, AN 3351, APP3351, Appnote3351, Appnote 3351

Copyright © by Maxim Integrated Products

Additional legal notices: www.maxim-ic.com/legal