



APPLICATION NOTE 3330

Build a Charge Pump with Ultra-Low Quiescent Current (I_q)

Abstract: Combining low-on-resistance analog switches with a reference and ultra-low quiescent current comparator produces a discrete-component regulated charge pump that delivers 10mA, with only 7uA of quiescent current (I_q).

Portable, battery-powered devices often spend most of their life in standby mode, where the quiescent current of an internal boost converter bleeds the battery continuously. The quiescent current during standby can be larger than the actual load current. Though several inductor-based converters offer amazingly low quiescent current (<10uA maximum), a regulated charge pump is preferred (or required) for cost-sensitive designs that must be intrinsically safe.

Off-the-shelf regulated charge pumps with output-current capabilities $\geq 10\text{mA}$ have typical minimum quiescent currents of 50 to 100 μA . If that level of quiescent current is not acceptable, you can reduce the overall average by adding circuitry that monitors the regulated voltage remotely and toggles the charge pump in and out of shutdown. That approach, however, may not achieve the desirable I_q level (<10 μA). The advent of low- R_{ON} analog switches and ultra-low-current comparators and references makes possible a discrete-component charge pump whose maximum quiescent current is about 7 μA .

Charge pumps use an ac-coupling technique to transfer energy from a transfer capacitor to a storage capacitor. The transfer capacitor is first charged via analog switches to the level of V_{BATT} , then other analog switches transfer the energy to a storage capacitor tied to V_{OUT} . The transfer capacitor is then charged again and the cycle repeats. With ideal analog switches exhibiting zero loss, the V_{OUT} level equals $2V_{\text{BATT}}$. As expected, however, the analog switches' finite R_{ON} produces an output level that drops in proportion to the load current.

A basic regulated charge pump (**Figure 1**) includes an oscillator, several analog switches, a voltage reference, and a comparator. The comparator serves as a voltage monitor and oscillator. When the circuit is in regulation the comparator output is low, which closes the NC switches and allows C1 to charge to V_{BATT} . When the voltage at V_{OUT} dips below the output-regulation threshold (3.3V in this case), the comparator output goes high. The NO switches close, transferring C1's charge to C2. This cycle repeats until V_{OUT} regains regulation.

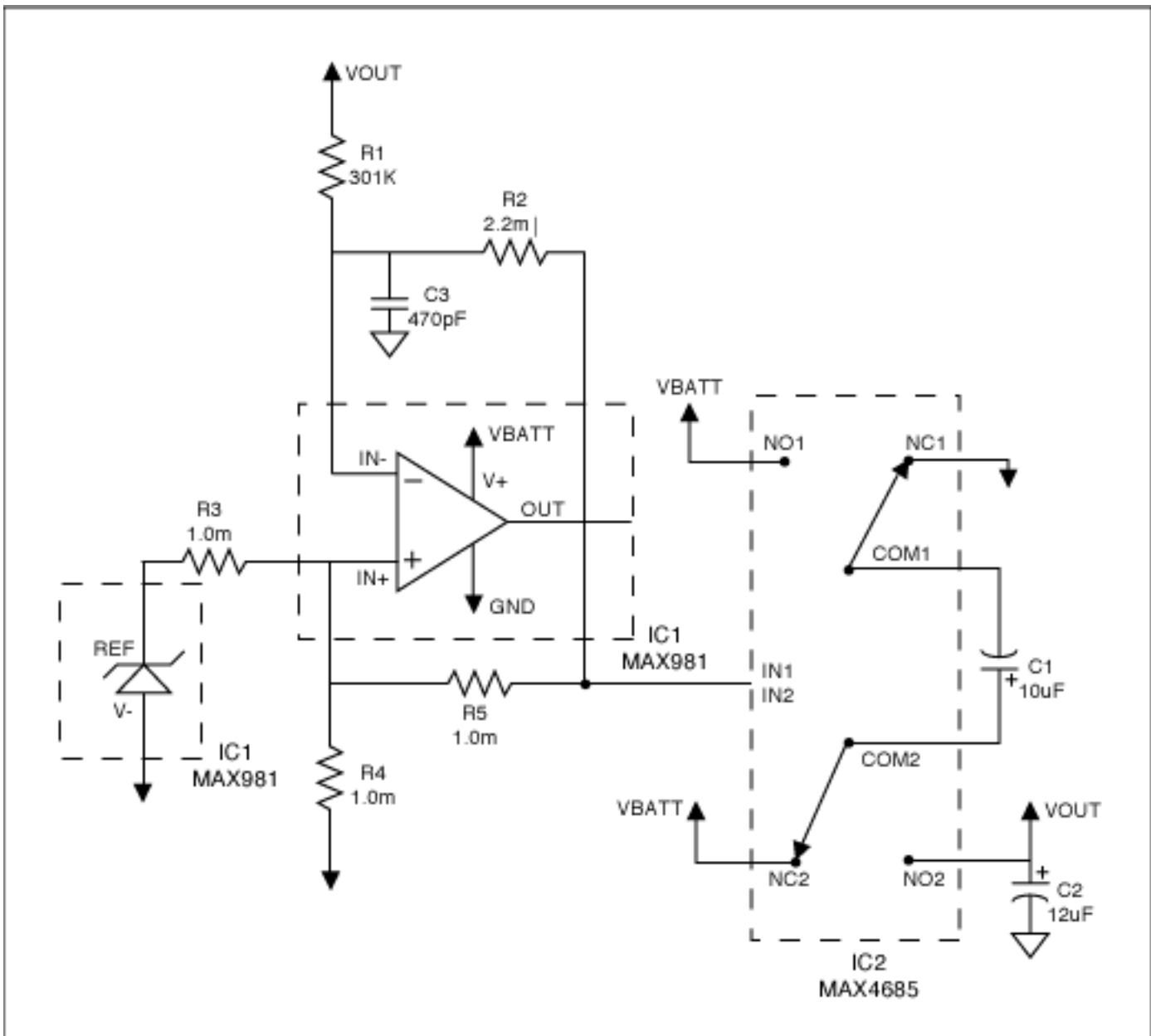

Figure 1. Low-Iq regulated charge pump.

Resistors R3-R5 form the hysteresis necessary for oscillation. Their value (1.0M Ω) creates a notable level of hysteresis while minimizing V_{BATT} loading. As the comparator output changes state, feedback resistor R5 creates hysteresis by moving the threshold applied to the comparator's IN+ input. For the resistor values shown, reference value nominal for IC1 (1.182V), and $V_{BATT} = 3.0V$, the V_{IN+} threshold swings between approximate values of $V_{IN+low} = 0.39V$ and $V_{IN+high} = 1.39V$.

When the circuit is in regulation, V_{IN-} slightly exceeds V_{IN+} , the comparator output is low, the voltage at V_{OUT} is sensed by the R1/R2 divider, and the threshold at V_{IN+} is low (0.39V). With V_{IN+} at 0.39V, the R1 and R2 values can be calculated from the following equation:

$$V_{IN+} = V_{OUT}(R2/(R1 + R2)).$$

The magnitude of $R1+R2$ should be greater than 1M Ω to minimize V_{BATT} loading. If $V_{OUT} = 3.3V$ and R2 is selected at 2.2M Ω , R1 is calculated at 301k Ω . Capacitor C3 connects to the comparator's IN- input. Along with R1 and R2, C3 sets the oscillation frequency according to the following simplified relationships:

$$t_{discharge} = t_{low} = -R2 * C3 * \ln(V_{IN+low}/V_{IN+high}).$$

$$t_{\text{charge}} = t_{\text{high}} = -R2 * C3 * \ln(1 - ((V_{\text{IN+high}} - V_{\text{IN+low}}) / (V_{\text{BATT}} - V_{\text{IN+low}}))).$$

$$f_{\text{osc}} = 1/t_{\text{period}}, \text{ where } t_{\text{period}} = t_{\text{low}} + t_{\text{high}}.$$

To maximize efficiency and reduce the effects of comparator slew rate, you should set a relatively low frequency. Choosing $C3 = 470\text{pF}$ yields the following:

$$t_{\text{low}} = 178\mu\text{sec} \text{ and } t_{\text{high}} = 68\mu\text{sec}; \text{ thus } f_{\text{osc}} = 4.0\text{kHz}.$$

The values of $C1$ and $C2$ are selected to achieve the desired load current and ripple. For this application ($I_{\text{load}} = 10\text{mA}$), choose $C1 = 10\mu\text{F}$. To calculate the value of $C2$, make an approximation based on the desired ripple voltage:

$$C2 = (I_{\text{load}} * t_{\text{low}}) / V_{\text{ripple}}.$$

$$\text{With } I_{\text{load}} = 10\text{mA} \text{ and } V_{\text{ripple}} = 150\text{mV}, C2 = 12\mu\text{F}.$$

With the component values shown, the circuit draws a maximum I_q of $6.9\mu\text{A}$ and offers a considerable improvement over off-the-shelf charge pumps. You can further lower the I_q value by increasing the resistor values, but that effect is minimal because IC2's quiescent current ($3.8\mu\text{A}$ maximum) dominates the total. This circuit lets you implement an ultra-low- I_q regulated charge pump. Until off-the-shelf options are available, it provides an alternative for designers seeking to implement a low-cost design without the use of inductors.

This design idea appeared in the August 5, 2004 issue of *EDN* magazine.

Application Note 3330: <http://www.maxim-ic.com/an3330>

More Information

For technical questions and support: <http://www.maxim-ic.com/support>

For samples: <http://www.maxim-ic.com/samples>

Other questions and comments: <http://www.maxim-ic.com/contact>

Related Parts

MAX4685: [QuickView](#) -- [Full \(PDF\) Data Sheet](#) -- [Free Samples](#)

MAX985: [QuickView](#) -- [Full \(PDF\) Data Sheet](#) -- [Free Samples](#)

AN3330, AN 3330, APP3330, Appnote3330, Appnote 3330

Copyright © by Maxim Integrated Products

Additional legal notices: <http://www.maxim-ic.com/legal>