

APPLICATION NOTE 3323

Power-Backup Switch

A microprocessor-supervisor IC and two external MOSFET switches form a low-voltage backup power supply that can provide several amperes when the main supply fails.

Every subsystem in an electronic product depends on a reliable power supply. One way to achieve high reliability is to have a backup power supply, in case the main supply fails. The classic method for adding backup power is to have each supply connected with a series diode to a common output. But with today's lower supply voltages, the power lost in the series diode's forward voltage drop becomes significant.

A few microprocessor supervisor ICs incorporate a voltage detector with an internal switch. Unfortunately, due to technology limitations, the internal switch has an impedance of 1 ohm or more, limiting the current handling to a couple of hundred milliamps. When power supplies need to supply several amps, external switches need to be added.

The circuit shown in the attached diagram depicts how to connect external switches to a microprocessor supervisor.

The BATT ON pin is high whenever the chip has detected a power failure and switches to the backup supply. Transistor T1 bypasses the internal switch for the main supply. Transistor T2 is an inverter, blocking T3. When the main power fails, BATT ON blocks T1, and enables T3, via T2. The external diodes are optional, to prevent glitches during switchover.

The supervisor chip can be a MAX6367, for instance, if a preset voltage for switching is required (in this case 3.08V). For non-standard voltages, the MAX794 can be used. Its voltage can be set with an external voltage divider.

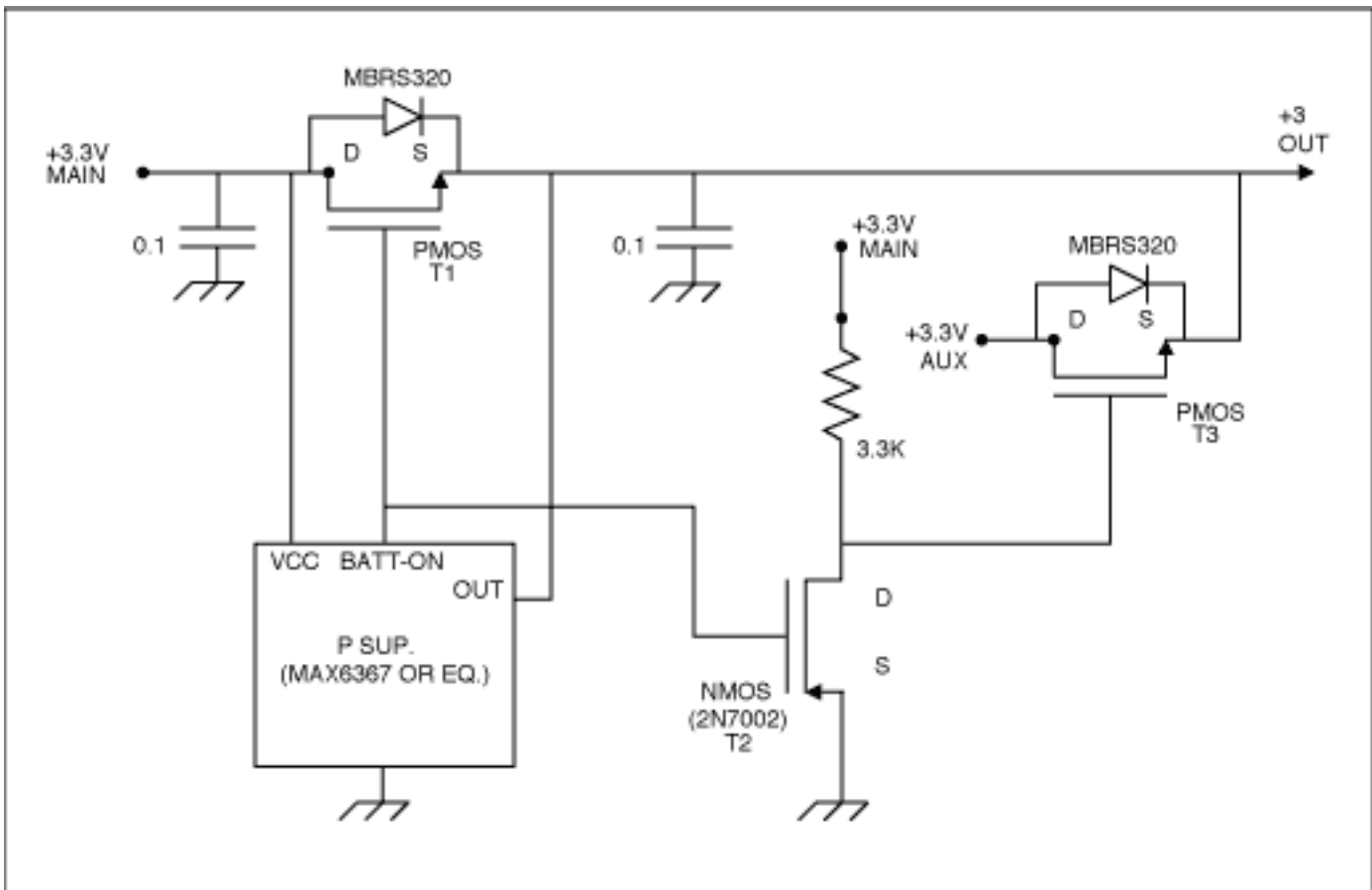

Figure 1. Power backup switch.

Application Note 3323: <http://www.maxim-ic.com/an3323>

More Information

For technical questions and support: <http://www.maxim-ic.com/support>

For samples: <http://www.maxim-ic.com/samples>

Other questions and comments: <http://www.maxim-ic.com/contact>

AN3323, AN 3323, APP3323, Appnote3323, Appnote 3323

Copyright © 2005 by Maxim Integrated Products

Additional legal notices: <http://www.maxim-ic.com/legal>