

APPLICATION NOTE 3313

# Interfacing a DS1390/DS1391 RTC with a Motorola DSP with SPI

*Abstract: This app note shows how to connect a DS1390 to a Motorola DSP that has a built-in SPI™ interface module. This circuit uses the Motorola DSP56F800DEMO Demonstration Board and CodeWarrior® IDE.*

## Description

The DS1390 Real-Time Clock (RTC) may be interfaced with a microcontroller (μC) or Digital Signal Processing (DSP) unit using a SPI interface. This app note shows how to connect a DS1390 to a Motorola DSP that has a built-in SPI interface module. This circuit uses the Motorola DSP56F800DEMO Demonstration Board and CodeWarrior IDE.

## Using the Example Software

The example software was developed by starting with a blank project. Follow the instructions in the Motorola Kit Installation Guide (Tutorial: Creating a CodeWarrior Project) for details. Add the code included in this application note in main.c.

## Operation

The program uses a GPIO port to control CS on the DS1390. The software initializes the SPI controller module and the DSP writes the time and date to the DS1390. The software then loops reading the time and date. The DS1390 and DS1391 support SPI modes 1 and 3.

A schematic of the circuit is shown in **Figure 1**. This circuit comprises a daughter card that is attached to the Motorola demo board. Please note that the circuit in Figure 1 includes several RTCs with SPI interfaces. Only one RTC may be used at a time, and the software only supports the DS1390. The software is shown in **Figure 2**.

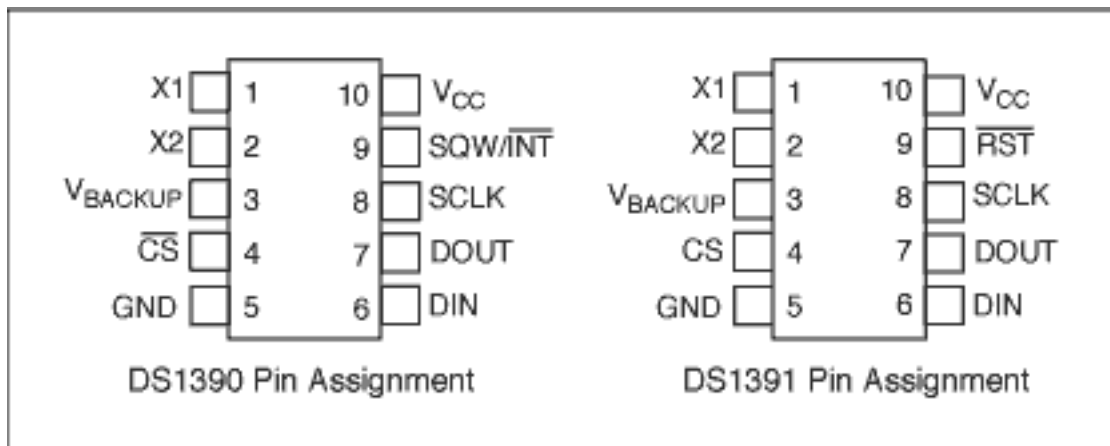
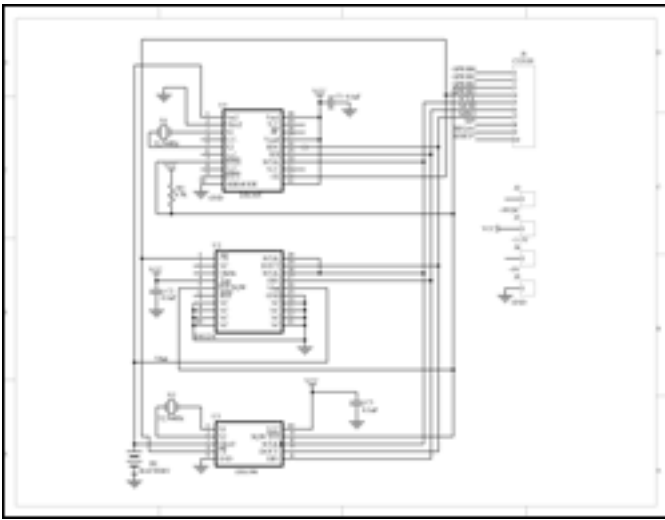

Figure 1.



[More detailed image](#) (PDF, 138kB)

Figure 2. Schematic of daughter card.

### Figure 3. Code Listing

```

/* File: DS1390.c */
/* This example program was developed using the Motorola
56F800 Demo Board Kit. Follow the kit installation guide
for creating a CodeWarrior Project. Use the shell of the
new project for this example. Note: This program is for
example only and is not supported by Dallas Semiconductor
Maxim. */

#include "port.h"
#include "stdio.h"
#include "stdlib.h"

/*****
* Main program for use with Embedded SDK
*****/

extern sampleASM (void);

void reset_spi(void);
void wbyte_spi(unsigned char);
void init_sci0(Word16);
tx_sci0(unsigned char);
void bcd2ascii(unsigned char);
unsigned char rbyte_spi(void);

#define REG_BASE 0x0000
#define SCI0_BASE 0x0F00
#define SPI_BASE 0x0F20
#define GPIOA_BASE 0x0FB0
#define GPIOB_BASE 0x0FC0

#define SCI0_SCIBR *(volatile UWord16 *)(SCI0_BASE + 0)
#define SCI0_SCICR *(volatile UWord16 *)(SCI0_BASE + 1)
#define SCI0_SCISR *(volatile UWord16 *)(SCI0_BASE + 2)
#define SCI0_SCIDR *(volatile UWord16 *)(SCI0_BASE + 3)

#define SPSCR *(volatile UWord16 *)(SPI_BASE + 0)
#define SPDSR *(volatile UWord16 *)(SPI_BASE + 1)

```

```

#define SPDRR *(volatile UWord16 *)(SPI_BASE + 2)
#define SPDTR *(volatile UWord16 *)(SPI_BASE + 3)

#define GPIO_A_PUR *(volatile UWord16 *)(GPIOA_BASE + 0)
#define GPIO_A_DR *(volatile UWord16 *)(GPIOA_BASE + 1)
#define GPIO_A_DDR *(volatile UWord16 *)(GPIOA_BASE + 2)
#define GPIO_A_PER *(volatile UWord16 *)(GPIOA_BASE + 3)

#define GPIO_B_PUR *(volatile UWord16 *)(GPIOB_BASE + 0)
#define GPIO_B_DR *(volatile UWord16 *)(GPIOB_BASE + 1)
#define GPIO_B_DDR *(volatile UWord16 *)(GPIOB_BASE + 2)
#define GPIO_B_PER *(volatile UWord16 *)(GPIOB_BASE + 3)

void main (void)
{
unsigned char   msec=0, min=0x26, sec=0x00, hr=0x17, dow=0x06,
                date=0x26, mon=0x12, yr=0x03, write = 0;

    reset_spi();
    init_sci0(195);                // 30MHz / 195 = 9600 baud

    GPIO_B_DR = 0x0008;           // disable RTC - CS high

    GPIO_B_DR = 0;                // enable RTC - CS low
    wbyte_spi(0x8d);              // control register write address
    rbyte_spi();                  // dummy read
    wbyte_spi(0x18);              // enable osc, 32kHz sqw
    rbyte_spi();
    GPIO_B_DR = 0x0008;           // disable RTC - CS high

    if(write)
    {
        GPIO_B_DR = 0;            // enable RTC - CS low
        wbyte_spi(0x80);          // select seconds register write address
        rbyte_spi();              // dummy read
        wbyte_spi(msec);          // milliseconds register data
        rbyte_spi();
        wbyte_spi(sec);           // seconds register data
        rbyte_spi();
        wbyte_spi(min);           // minutes register
        rbyte_spi();
        wbyte_spi(hr);            // hours register
        rbyte_spi();
        wbyte_spi(dow);           // day of week register
        rbyte_spi();
        wbyte_spi(date);          // date register
        rbyte_spi();
        wbyte_spi(mon);           // month register
        rbyte_spi();
        wbyte_spi(yr);            // year register
        rbyte_spi();
        GPIO_B_DR = 0x0008;       // disable RTC - CS high
    }
    while(1)
    {
        GPIO_B_DR = 0u;           // enable RTC - CS low

        wbyte_spi(0);             // seconds register read address
        rbyte_spi();              // dummy read
        wbyte_spi(0);
        msec = rbyte_spi();        // read milliseconds register
    }
}

```

```

        wbyte_spi(0);
        sec = rbyte_spi();           // read seconds register
        wbyte_spi(0);
        min = rbyte_spi();          // ditto minutes
        wbyte_spi(0);
        hr = rbyte_spi();           // and so on
        wbyte_spi(0);
        dow = rbyte_spi();
        wbyte_spi(0);
        date = rbyte_spi();
        wbyte_spi(0);
        mon = rbyte_spi();
        wbyte_spi(0);
        yr = rbyte_spi();

        GPIO_B_DR = 0x0008;         // disable RTC - CS high

        tx_sci0(0x0d);              // sequence to print time & date
        tx_sci0(0x0a);
        bcd2ascii(yr);
        tx_sci0('/');
        bcd2ascii(mon);
        tx_sci0('/');
        bcd2ascii(date);
        tx_sci0(' ');
        bcd2ascii(hr);
        tx_sci0(':');
        bcd2ascii(min);
        tx_sci0(':');
        bcd2ascii(sec);
    }

    return;
}

//SPSCR
//15 14 13 12 11 10 9 8 7 6 5 4 3 2 1 0
// r MSB SPRF ERRIE ovrfl modfl sptfl modfln sprl spr0 sprle spmstr cpol cpha spe spite

void reset_spi()
{
    int val;
    SPSCR = 0x0056; // SPR0, SPMSTR, CPHA, SPE
    SPDSR = 0x0007; // 8-bit size

    SPSCR &= 0xfffd; // clear spe, resets SPI (partial)
    SPSCR |= 0x0002; // set spe, new values take effect

    GPIO_B_PER = 0x00f3; // use GPIOB3 as CS for RTC
    GPIO_B_DDR = 0x000d; // direction is output

    GPIO_A_PER = 0x00f9; // enable/disable per function (1=enable)
    GPIO_A_DDR = 0x0006; // direction is output (1=output)
    GPIO_A_DR = 0; // write bits low (0=low)
}

void wbyte_spi( unsigned char wbyte) // ----- write one byte -----
{
    while (!(SPSCR & 0x0200)); // wait for transmitter empty flag

```

```

        SPDTR = wbyte;
    }

void    bcd2ascii(unsigned char dat)    // ----- convert bcd to ascii and send to sci ----
{
    tx_sci0( (dat >> 4) + 0x30);
    tx_sci0( (dat & 0x0f) + 0x30);
}

unsigned char rbyte_spi(void)    // ----- read one byte -----
{
    while (!(SPSCR & 0x2000));    // wait for receiver full flag

    return(SPDTR);
}

void    init_sci0(Word16 baud)
{
    GPIO_B_PER = 0x00f3;    // set up
    GPIO_B_DDR = 0x000d;    // direction is output

    SCI0_SCIBR = baud;    // baud rate
    SCI0_SCICR = 0x2000;    // control reg
}

tx_sci0(unsigned char val)
{
    UWord16 reg;

    SCI0_SCICR &= 0xfffb;    // turn receiver off
    SCI0_SCICR |= 8;    // turn transmitter on
    do
    {
        reg = SCI0_SCISR;    // clear flag by reading
    } while( (reg & 0x8000) == 0);    // wait until RDRF is false

    SCI0_SCIDR = (unsigned int) (val);
}

```

---

Application Note 3313: <http://www.maxim-ic.com/an3313>

### More Information

For technical questions and support: <http://www.maxim-ic.com/support>

For samples: <http://www.maxim-ic.com/samples>

Other questions and comments: <http://www.maxim-ic.com/contact>

### Related Parts

DS1390: [QuickView](#) -- [Full \(PDF\) Data Sheet](#) -- [Free Samples](#)

DS1391: [QuickView](#) -- [Full \(PDF\) Data Sheet](#) -- [Free Samples](#)

AN3313, AN 3313, APP3313, Appnote3313, Appnote 3313

Copyright © by Maxim Integrated Products

Additional legal notices: <http://www.maxim-ic.com/legal>