



APPLICATION NOTE 3306

The Advantages of the DS2120 Low Voltage Differential (LVD) Device in a SCSI Environment

Abstract: This paper describes the differences between SCSI, FAST SCSI, and ULTRA SCSI. It also describes how to connect the DS2120 SCSI Terminator and what voltage levels should be applied. It also describes the MSTR/SLV function with regards to DIFF_CAP and DIFFSENS.

Also See: [SCSI Terminators Homepage](#)

The choice of SCSI (Small Computer System Interface) transceivers, whether single-ended (SE) or differential (HVD or LVD), determines the speed of data transfers, the length of cable, and the number of devices that can be supported by a host controller.

Since its inception in 1981, SCSI¹, now referred to as SCSI-1, relied exclusively upon single-ended, 8-bit wide bus transceivers for host to peripheral data transfers. It is defined with speeds up to 5 megabytes per second. SCSI has evolved since then. SCSI-2, defines speeds up to 10 megabytes per second with optional high voltage differential drivers (HVD) and a wide (16-bit wide) data bus. SCSI-3 SPI™ extends the evolution to 20 megabytes per second with a wide HVD bus. With the advent of Ultra SCSI, Ultra2, Ultra 160, and now Ultra 320, data bus transfers can reach up to 320 megabytes per second. (See Table 1.0 below).

Table 1. STA-Endorsed Terms & Terminology for SCSI

STA Terms	Bus Speed, MBytes/Sec. Max.	Bus Width, bits	Max. Bus Lengths, Meters (1)			Max. Device Support
			Single- Ended	LVD	HVD	
SCSI-1 (2)	5	8	6	(3)	25	8
Fast SCSI (2)	10	8	3	(3)	25	8
Fast Wide SCSI	20	16	3	(3)	25	16
Ultra SCSI (2)	20	8	1.5	(3)	25	8
Ultra SCSI (2)	20	8	3			4
Wide Ultra SCSI	40	16		(3)	25	16
Wide Ultra SCSI	40	16	1.5			8
Wide Ultra SCSI	40	16	3			4
Ultra2 SCSI (2,4)	40	8	(4)	12	25	8
Wide Ultra2 SCSI (4)	80	16	(4)	12	25	16
Ultra3 SCSI or Ultra160 SCSI (6)	160	16	(4)	12	(5)	16
Ultra320 SCSI (6)	320	16	(4)	12	(5)	16

Notes:

- (1) The listed maximum bus lengths may be exceeded in Point-to-Point and engineered applications.
- (2) Use of the word "Narrow", preceding SCSI, Ultra SCSI, or Ultra2 SCSI is optional.
- (3) LVD was not defined in the original SCSI standards for this speed. If all devices on the bus support LVD, then 12-meters operation is possible at this speed. However, if any device on the bus is single-ended only, then the entire bus switches to single-ended mode and the distances in the single-ended column apply. A distance of 25-meters is possible in LVD point-to-point applications.
- (4) Single-ended is not defined for speeds beyond Ultra.
- (5) HVD (Differential) is not defined for speeds beyond Ultra2.
- (6) After Ultra2 all new speeds are wide only.

HVD SCSI was introduced as part of the SCSI-2 specification in an effort to increase speed, distance, and the number of devices available on the bus. HVD extends the length of cable to 25 meters (82 feet) and with Fast Wide SCSI, allows up to 16 SCSI devices (including the host adapter) on the bus. However, HVD SCSI requires high-powered transceivers and uses a differential voltage signal to determine the logical state of the bus. Parallel signal voltages (a positive and a negative voltage) sent along the bus establish the differential voltage. If $(V+) - (V-)$ is a positive value, then the receiver detects a logical one. If $(V+) - (V-)$ is a negative value, the receiver detects a logical zero. The differential bus is less prone than the SE bus to noise and ground shifts, since any interference on the bus will manifest itself on both $(V+)$ and $(V-)$, effectively canceling itself out. For this reason, the differential bus is called a balanced bus. This approach allows for a longer cable length and minimizes the effects of noise. But the high-powered transceivers that a balanced bus requires will not fit onto a one or two-chip controller chip set, making a differential bus impractical for most cost-effective applications.

The LVD SCSI, introduced in 1995, provides the low power, low cost of single-ended transceivers with the signal integrity, along with high-speed capability of HVD SCSI. Each LVD $(V+)$ and $(V-)$ signal swings about $\pm 400\text{mV}$ around a common mode bias voltage of 1.25V. This small amount of change allows the signal to achieve its desired state more quickly than in single-ended or high voltage differential signaling. With LVD SCSI, based upon the EIA-644 (LVDS) standard for data transmissions over a copper wire, speeds of up to 655 megabytes per second can be reached (point-to-point). Another advantage of LVD SCSI over HVD SCSI is its backward compatibility to SE SCSI². Speed and distance for SE and HVD are not defined for Ultra3 or Ultra 160 and beyond. Specifications beyond Ultra 160 are clearly defined only for LVD, see Table 1.0.

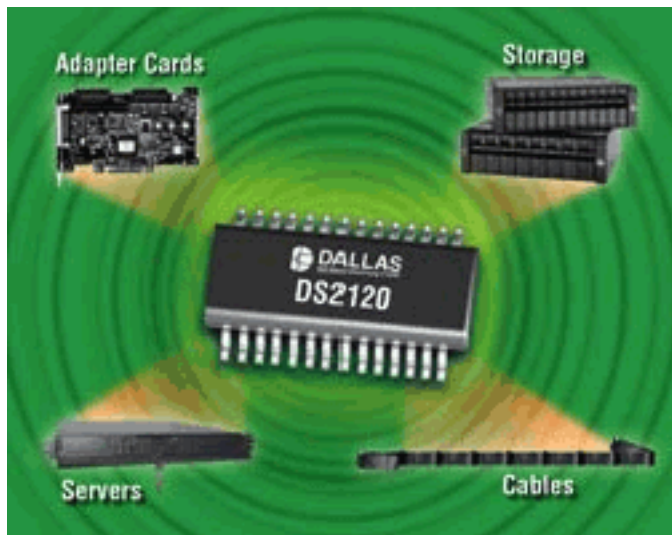

The DS2120 LVD SCSI terminator is fully compliant with Ultra320, Ultra3 or Ultra160, and Ultra 2 (LVD only) SCSI interface requirements. Since the DS2120 is an LVD-only SCSI terminator, SE or HVD devices connected to the bus will cause the DS2120 to automatically disconnect from the bus. This is accomplished inside the part automatically by sensing the voltage on the DIFFSENS line. LVD termination is provided by 5% tolerance laser-trimmed resistors biased with two current sources and a common-mode voltage source generated from a bandgap reference of 1.25V. The configuration is a y-type terminator with a 105 Ω differential and a 150 Ω common-mode resistance. A failsafe bias of 112mV is maintained when no drivers are connected to the LVD SCSI bus. Another failsafe is the bandgap temperature-to-voltage converter used to determine when the device exceeds 150°C. Once the thermal shutdown temperature is reached, the device is electrically isolated from the bus.

The DIFF_CAP pin monitors the DIFFSENSE line to determine the proper operation mode of the device. If the voltage on the DIFF_CAP is between 0.7V and 1.9V, the device enters LVD mode after the mode-change delay. Three DS2120 LVD terminators are needed for wide SCSI applications (See **Figure 1.0**). In a typical application the SCSI devices are daisy-chained as shown below. The DIFFSENSE pin can also drive the SCSI DIFFSENSE line when (MSTR/SLV) = 1 to determine the proper operating mode.

Internal to these devices, there is a 75kΩ pull-up between TPWR and the MSTR/SLV lines. Because of the internal pull-up, the MSTR/SLV line can be tied high, as shown in Figure 1.0 or optionally it can be left floating³.

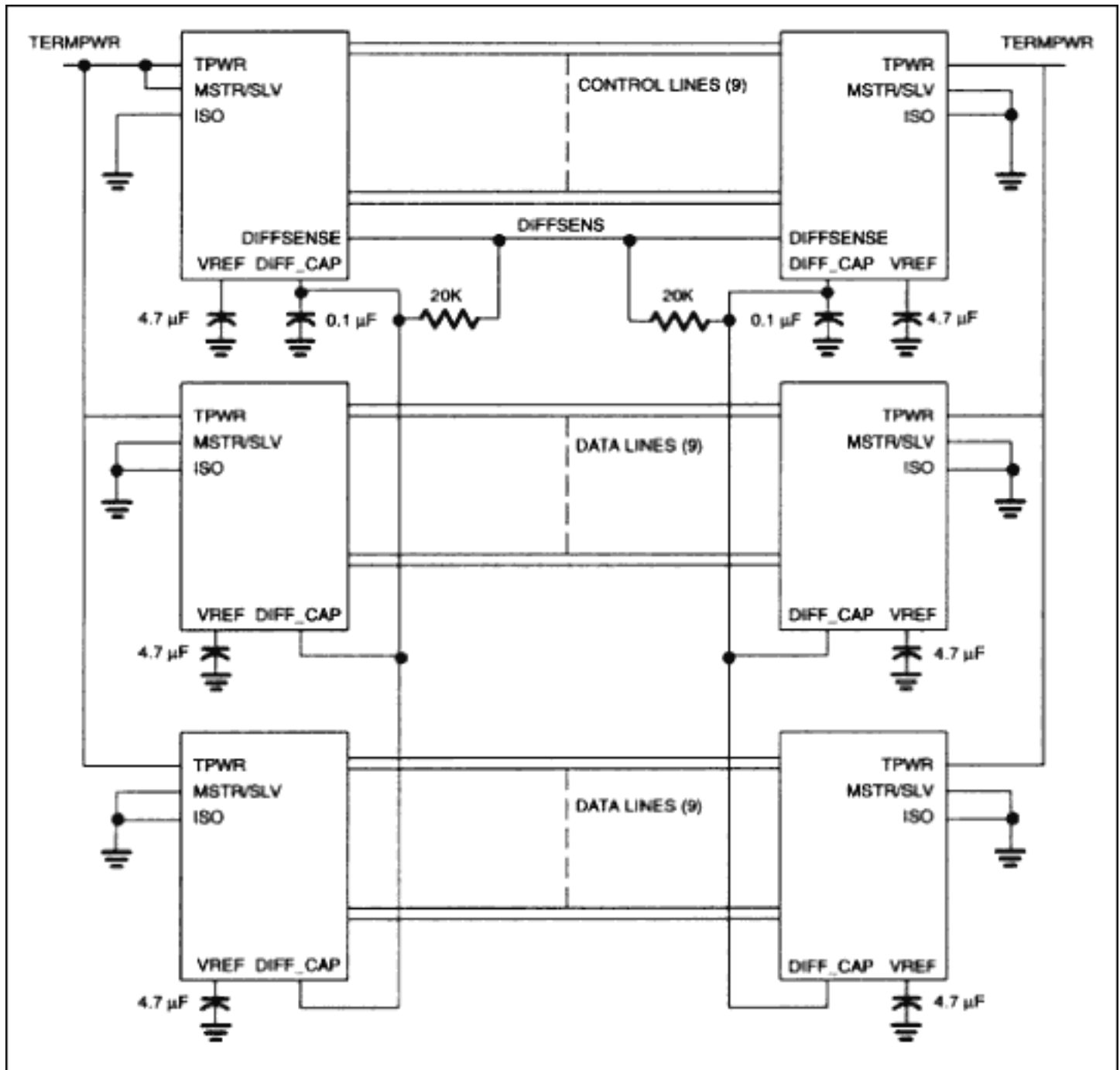

Figure 1.

The DS2120 is a high-performance LVD SCSI terminator. It is designed to provide the speed of HVD SCSI terminators, without the associated power consumption and real estate requirements. In the above configuration, only one set of terminators would typically reside on the host bus adapter (HBA), while the other set would exist in a small connector package at the end of the SCSI cable. The DS2120E resides in a small 28-pin 4.4mm TSSOP package. The complete packaging solution can easily be designed onto the end of a cable assembly or a cable adapter. The DS2120 also provides low power-down capacitance of 3pF and is hot-plug compatible. The operating ranges are from 2.7V to 5.5V and 0°C to 70°C.

¹ See SCSI Trade Association (STA) website: <http://www.scsita.org>

² Any version of SCSI, including LVD SCSI, must be backward compatible by definition. The new standard uses a sensor, called the diffsense line for differentiation sensor, to differentiate among the various varieties. The terminators output a signal voltage to the diffsense line to differentiate among SE, HVD, and LVD. An SE bus will use a diffsense voltage less than 0.5V. A diffsense voltage between 0.7V and 1.9V denotes an LVD bus, and a diffsense voltage greater than 2.4V denotes a HVD bus.

³ See Application Note 510: [SCSI Bus Configuration For MSTR/SLV Connections](#)

SPI is a trademark of Motorola, Inc.

Application Note 3306: <http://www.maxim-ic.com/an3306>

More Information

For technical questions and support: <http://www.maxim-ic.com/support>

For samples: <http://www.maxim-ic.com/samples>

Other questions and comments: <http://www.maxim-ic.com/contact>

Related Parts

DS2120: [QuickView](#) -- [Full \(PDF\) Data Sheet](#)

DS2125: [QuickView](#) -- [Full \(PDF\) Data Sheet](#)

AN3306, AN 3306, APP3306, Appnote3306, Appnote 3306

Copyright © by Maxim Integrated Products

Additional legal notices: <http://www.maxim-ic.com/legal>