



APPLICATION NOTE 3303

Get A Grip On Clamps, Bias and AC-Coupled Video Signals

Abstract: This article explains clamps, bias, and AC-coupled video signals, the appropriate signals for each, the merits and drawbacks of dual and single power supplies, and why some circuits are inherently better for some applications.

Why should you AC-couple your video signals?

If you haven't asked this question, you should. If the reason is government mandate, customer specification, or industry protocol, you're probably doing the right thing! In many cases, it's because the application has a single supply, and you feel that you must AC-couple. Maybe you still have dual supplies, because going to a single supply will involve AC-coupling the video, which will compromise the video quality.

So before we go any further, let's look at some facts. Single-supply circuits are fed by single-supply sources, such as a digital-to-analog converter (DAC), and the DAC's output can be level-translated (a DC operation) to ensure dynamic range above ground at the output. A common mistake in implementing this approach discretely is thinking that because an op amp can sense a signal below ground, it can reproduce it at the output. That's incorrect. Integrated, single-supply solutions are the real answer, but the industry will have to accept offset DC levels for their video outputs, similar to what SCART does in Europe (SCART is an industry standard for interconnecting audio-visual equipment, developed by the French company Peritel).

Of course, AC-coupling a video signal creates a problem. The signal's DC voltage level must be re-established afterwards to set image brightness and ensure that the signal falls within the linear region of the next stage. That operation, called "biasing," employs different circuits, depending on the video signal's waveform and the accuracy and stability required of the bias point. Sine-wave signals, like audio, use resistor-capacitor (RC) coupling to establish a stable bias voltage.

Unfortunately, only the chroma signal (C) of S-Video even approximates a sine wave. Luma (Y), composite (Cvbs), and RGB are complex signals that vary in one direction from a reference level, below which a sync waveform may be attached. Such signals require a form of bias method unique to video called clamping, because it "clamps" one extreme of the signal to a reference voltage, leaving the other extreme to vary. The classic form of this is a diode clamp, where the diode is activated by the sync on the video. But there are others.

For example, the color-difference signals (Pb and Pr) and graphics RGB are better handled by a "keyed clamp." This circuit replaces the diode with a switch, allowing external control of where the video is clamped using an external (key) signal. The last biasing method, called a "DC restore," adds feedback to a keyed clamp to improve the bias point's accuracy, prior to an analog-to-digital converter (ADC).

AC-Coupling Of Video Signals

When any signal is AC-coupled, the coupling capacitor stores the sum of the (signal's) average value, and the difference in DC potential between the source and the load. To illustrate how this affects the stability of a bias point for different signals, look at **Figure 1**. Shown is the difference between a sine wave and a pulse when AC-coupled to a grounded resistor load.

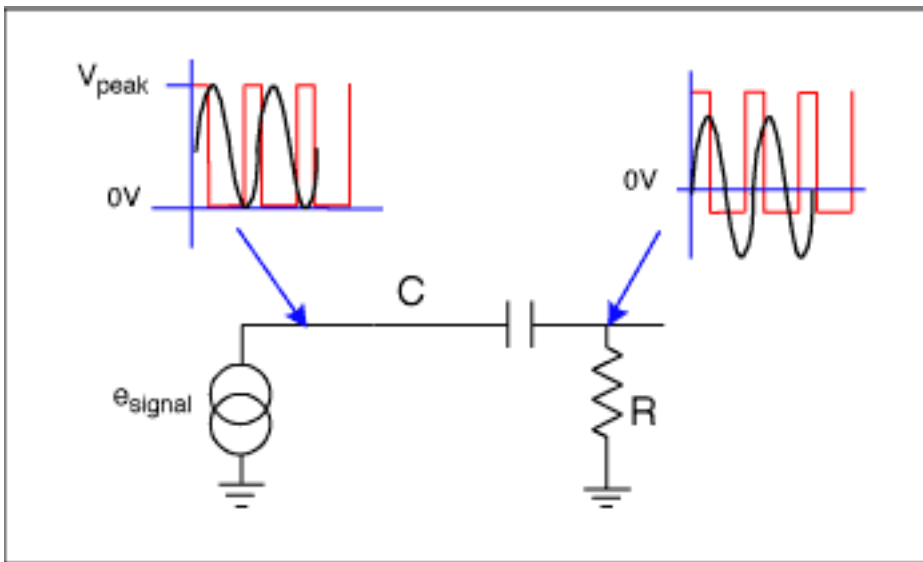

Figure 1. Simple RC coupling for a sinewave and a pulse give different bias points.

Initially, both signals vary around the same voltage. But after passing through the capacitor, they differ. The sine wave varies around its half-amplitude point, while the pulse varies around a voltage that's a function of the duty cycle. This means that if you AC-couple, you need more dynamic range for a variable-duty-cycle pulse than for the same-size sine wave. For this reason, all amplifiers for pulse applications are DC-coupled to preserve dynamic range. Video is just like a pulse, and prefers DC-coupling.

The video signals you will likely encounter are shown in **Figure 2**, with the standard amplitudes found in video interfaces (see EIA 770-1, 2, and 3). Chroma in S-Video, and Pb and Pr in component video, resemble the sine wave varying around a reference point, as noted above. Luma (Y), composite, and RGB only vary in a positive direction from 0V (called the "black" or "blank" level) to +700mV. This is due to a tacit agreement within the industry and not to any standard. Note that they all are complex waveforms with a sync interval that may or may not be defined or even used. For example, Figure 2 shows RGB with sync as used in NTSC and PAL formats. In PC (graphics) applications, the sync is a separate signal, and RGB doesn't have it attached. In single-supply applications, such as a DAC output, the quiescent levels could be different during the sync interval. This will influence the choice of bias method. For example, if the quiescent level of chroma isn't 0V during the sync interval in a dual-supply application, it will be more pulse-like than sinusoidal.

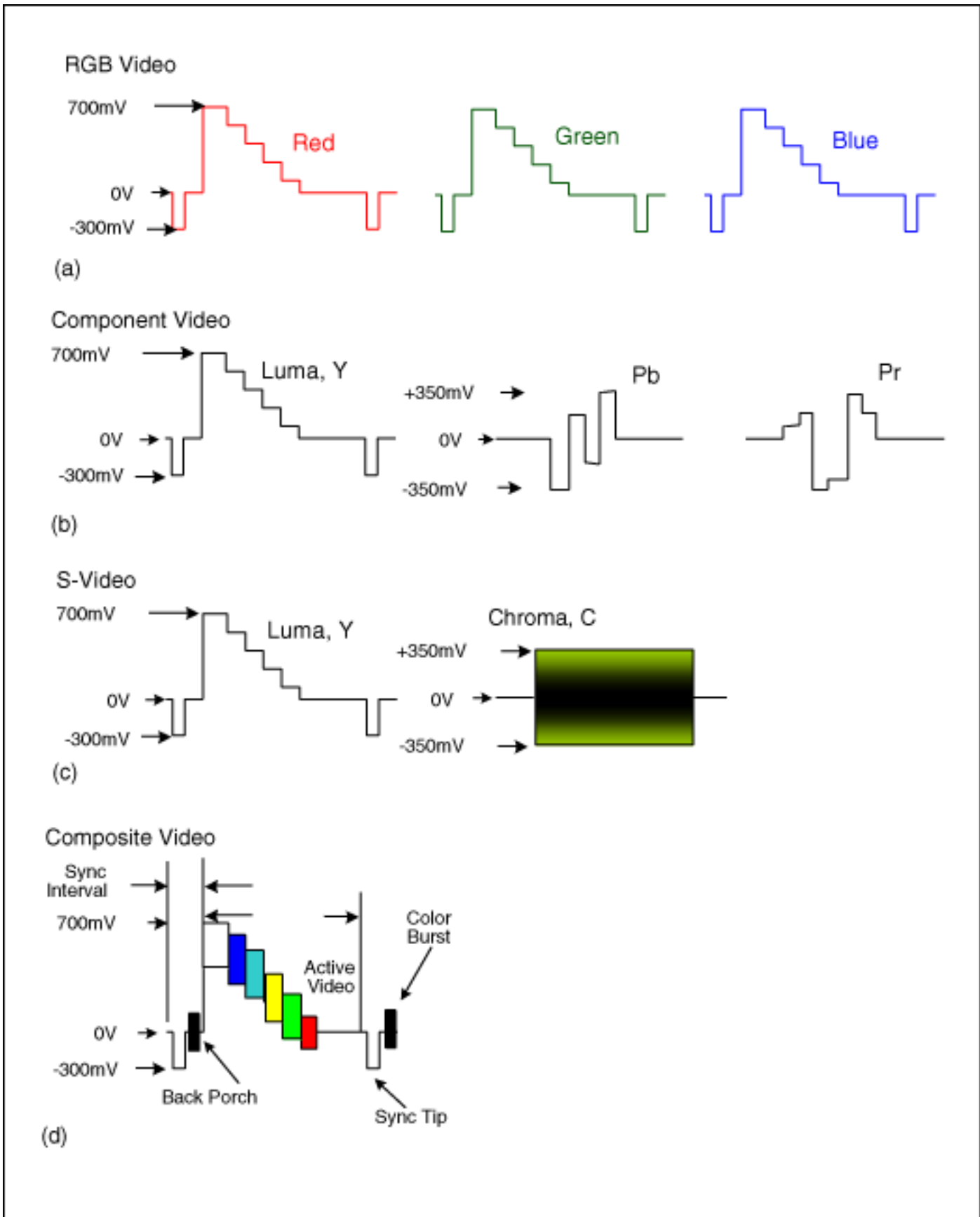

Figure 2. These RGB (a), Component (b), S-Video (c), and Composite (d) Video Signals show the Sync interval, Active video, Sync Tip, and Back Porch.

Despite these complications, video signals must be AC-coupled at the point where the voltage domains change. Connecting two different power sources through a DC connection is dangerous, and usually forbidden by safety regulations. Consequently, video-equipment makers have a tacit agreement to AC-couple the input of their equipment, and DC-couple the output—requiring the next stage to re-establish the DC component (see EN

50049-1 for PAL/DVB [SCART] and SMPTE 253M section 9.5 for NTSC, which allow a DC output level). Failure to establish such a protocol leads to "double coupling," where two coupling capacitors appear in series, or to a short where there are no capacitors. The sole exception to this rule is battery-powered equipment, such as camcorders and still cameras, which AC-couple the output to minimize battery drain.

The next question is how large must this coupling capacitor be? In Figure 1, the assumption that the capacitor stores the signal's "average voltage" is predicated on the RC product being greater than the minimum period of the signal. So to ensure good averaging, the lower -3dB point of the RC network must be below the lowest frequency of the signal by a factor of 6 to 10 times. However, this results in a large range of capacitance values.

For example, chroma in S-Video is a phase-modulated sine wave whose lowest frequency is about 2MHz. Even with a 75Ω load, only 0.1μF is required, unless you need to pass the horizontal sync interval. In contrast, the frequency response of Y (luma), Cvbs (composite), and RGB extend down to the video frame rate (25Hz to 30Hz). Assuming a 75Ω load, and a 3Hz to 5Hz -3dB point, this requires greater than 1000μF. Using too small a capacitor causes the displayed image to darken from left to right, top to bottom, and can distort the image spatially (depending on the capacitor's size). In video, this is called line droop and field tilt. To avoid visible artifacts, their levels should be less than 1% to 2%.

Single-Supply Bias Circuits For Video

RC-coupling, as shown in **Figure 3a**, works on any video signal, as long as the RC product is large enough. Also, the supplies on the op amp following it must have sufficient range to handle the negative and positive excursions around the signal's average value. In the past, this was accomplished by using dual supplies on the op amp. Assuming that R_S is referred to the same ground as R_i , and equal to R_i in parallel with R_f , the op amp rejects any common-mode noise (that is, its common-mode rejection ratio [CMRR] is high) with minimum offset voltage. The lower -3dB point is $1 / (2R_S C)$. Also, despite the coupling capacitor's size, the circuit retains its power-supply rejection ratio (PSRR), CMRR, and dynamic range. Most video circuits were built this way, and most AC-coupled studio applications still are built in this fashion.

With the advent of digital video and battery-operated devices, the negative supply became a cost and power burden. Early attempts at RC bias looked like **Figure 3b**, which uses a voltage divider. Assuming $R1 = R2$ and V_{CC} equals the sum of V_{CC} and V_{EE} in Figure 3a, the two circuits are similar. But they have different ac performance. To illustrate, any change in V_{CC} in Figure 3b directly changes the op amp's input voltage by the divider ratio, while in Figure 3a it's absorbed by the power-supply headroom of the op amp. With $R1 = R2$, the PSRR of Figure 3b is only -6dB. Consequently, the supply must be filtered and well regulated.

A cheaper alternative inserts an isolating resistor (RX) to improve the ac PSRR (**Figure 3c**). However, this approach causes additional DC offset unless matched to the parallel value of R_f and R_i . Exacerbating this is the requirement that the $R_x C1$ and $C2 R_i$ products must be less than 3Hz to 5Hz as noted above. Although a larger bypass capacitor (C3) in this circuit allows a smaller RX and reduces the offset voltage, it also makes C1 larger. This approach can be seen in low-cost designs using electrolytic capacitors.

The alternative is **Figure 3d**, which replaces the voltage divider with a three-terminal regulator and extends the PSRR down to DC. The regulator's low output impedance allows RX to be closer to the parallel combination of R_f and R_i , reducing the circuit's offset voltage. Because the only purpose of C3 is reducing noise from the regulator and complementing the regulator's output impedance (Z_{out}) as a function of frequency, its value is smaller than in Figure 3c. However, C1 and C2 can still be large, and CMRR is a problem for frequencies below the $R_i C1$ product, as is stability.

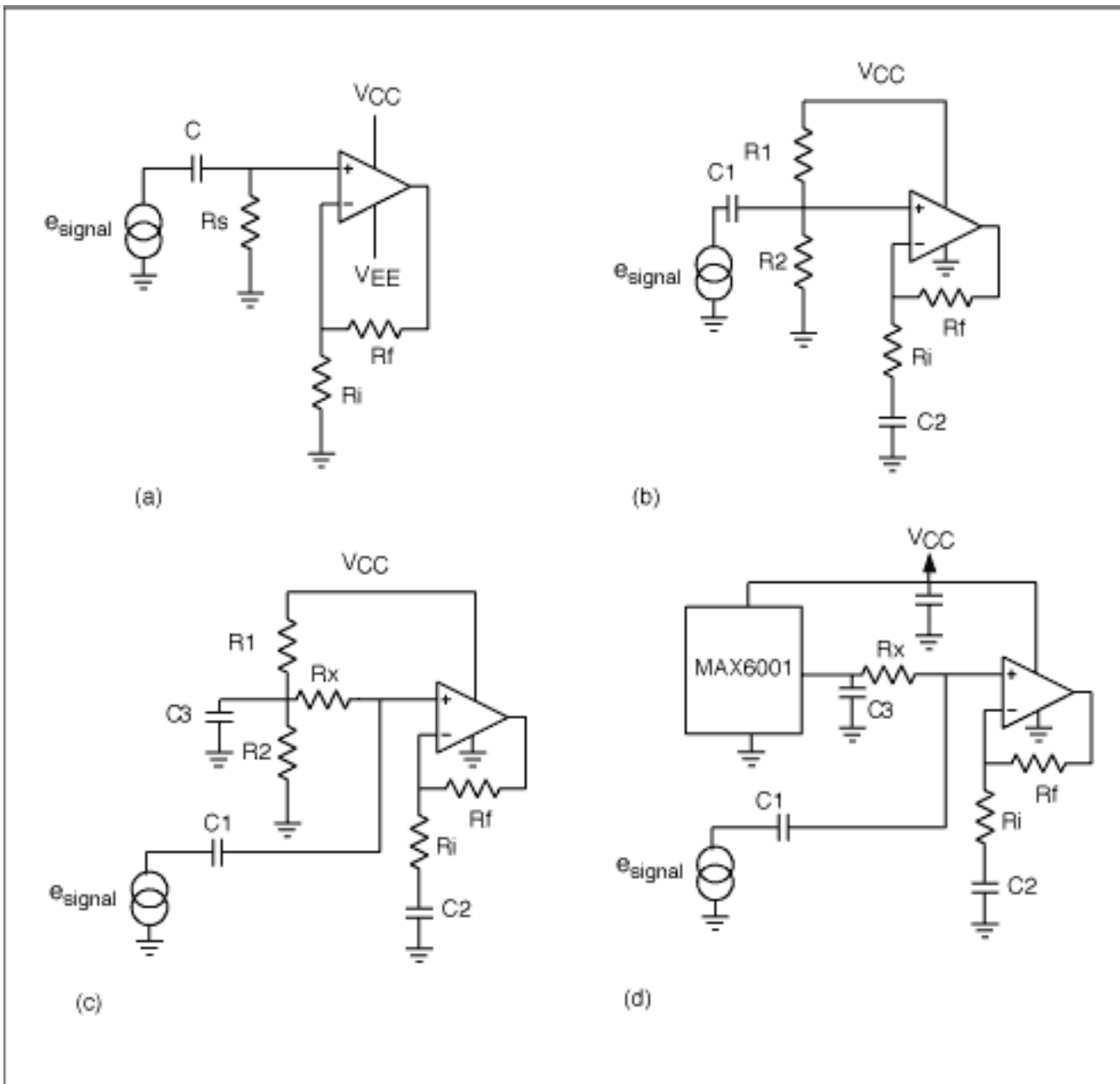

Figure 3. RC bias techniques include dual supplies (a), a single supply using a Voltage Divider (b), a voltage divider with lower offset (c), and a voltage regulator with improved PSRR (d).

After all is said and done, AC-coupling with dual supplies is better than the single-supply methods (with respect to common-mode and power-supply rejection)—regardless of the application.

Video Clamps

Luma, composite, and RGB signals vary from a reference level of black (0V) to a maximum (+700mV) with sync (-300mV) attached. But, like the variable-duty-cycle pulse in Figure 1, if these signals are AC-coupled, the bias voltage will vary with video content (called average picture level or APL) and the brightness information will be lost. What's needed is a circuit that holds the black level constant, regardless of the video or sync amplitude.

The circuit shown in **Figure 4a**, called a diode clamp, attempts to do this by replacing the resistor with a diode (CR). The diode acts as a one-way switch. Thus, the video signal's most negative-going voltage, the tip of the horizontal sync waveform, is forced to ground. Hence the circuit's other name, sync tip clamp. This will hold the reference (0V) constant, assuming the sync voltage (-300mV) doesn't change and the diode conduction potential is zero. Although you can't control the sync level, you can reduce the conduction potential by putting the clamp diode in the feedback loop of an op amp to make an "active clamp." A major problem with these is that they tend to oscillate if improperly terminated, and are seldom used in discrete design. Integrated forms can be

compensated, and are more reliable. (Examples include the MAX4399 and MAX4090.)

If the sync level varies or isn't present, the diode can be replaced by a switch—usually a FET controlled by an external signal (**Figure 4b**). This is a keyed clamp, and the control signal is the key signal. If the key signal is coincident with the sync pulse, then this becomes a sync tip clamp. But unlike the diode clamp, it can be activated anywhere in the sync interval, and not just during the sync tip. If the key signal occurs while the video is at the black level (**Figure 4c**), you get a "black-level clamp." This approach is versatile, practical, and closely approximates its ideal model. The switch doesn't have the diode's conduction voltage, and can actually implement a black-level clamp.

Adding a DC voltage source (V_{ref}) makes it possible to set bias for signals like chroma, Pb, and Pr, as well as composite and luma. Its shortcomings are that it requires a sync separator to get the key signal, and it's not accurate enough for some applications. If you're digitizing video, you want the black level to vary less than ± 1 least-significant bit (LSB), or about $\pm 2.75\text{mV}$. Clamps can't achieve that level of accuracy.

The last method used to bias a video signal is called a DC restore, and it can achieve black-level accuracy approaching ± 1 LSB. The first thing you notice in **Figure 4d** is that this circuit doesn't have a coupling capacitor. Instead, U2 compares the DC output of the stage (U1) to a voltage (V_{ref}), and applies negative feedback to U1 to force the output to track it regardless of the input voltage. Obviously, if the loop ran continuously, all you would get out is DC. Instead, a switch is inserted in the feedback loop. And it's only closed for an instant during each horizontal line at the point (sync tip or black level) we wish to set to V_{ref} . The voltage is stored on a capacitor (C), but it's not in series with the input. Instead it's in a sample-and-hold (S/H) formed by the switch in the feedback.

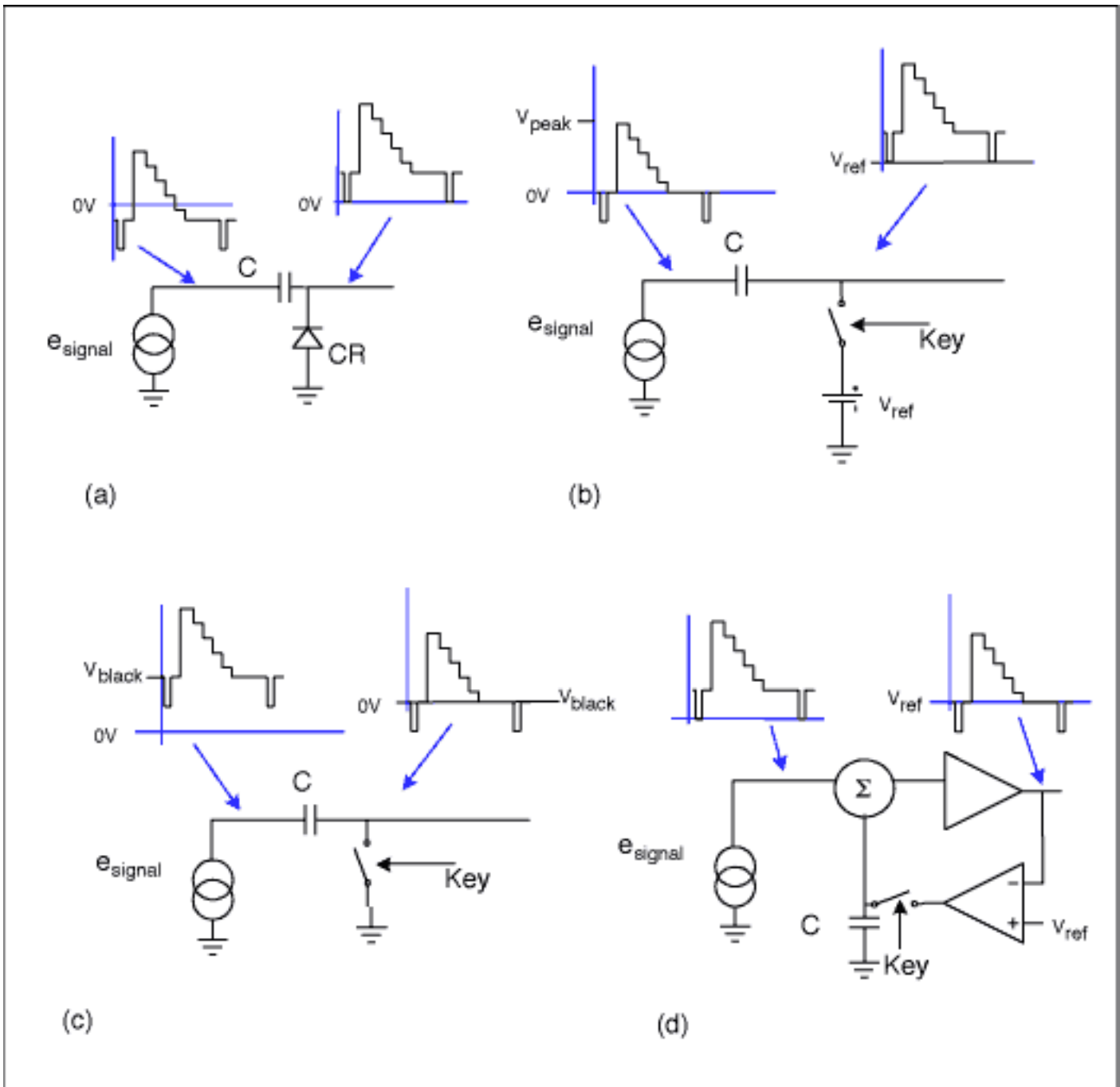

Figure 4. Different types of video clamp, a) Diode or sync tip clamp, b) Keyed clamp with reference voltage used as a sync tip clamp, c) Keyed clamp used as a black level clamp, d) DC restore.

The practical implementation of **Figure 5** actually has two capacitors (C_{hold} and C_x), two op amps (U1 and U2), and an S/H. The actual comparison and signal averaging is done by R_x , C_x , and U2. The RC product is chosen for noise averaging. For a 16ms field (NTSC/PAL), the RC product should be greater than 200 ns. So U2 is a low-frequency device chosen for its low offset voltage/current, and stability—not its frequency response. (The MAX4124/25 are good candidates for this application.) U1, on the other hand, is chosen for its frequency response, but not its offset. The S/H and C_{hold} itself are chosen for their leakage, which causes the voltage to change (droop) during a horizontal line. Although the circuit shown uses dual supplies, it can also be implemented in single-supply form using precision level translation.

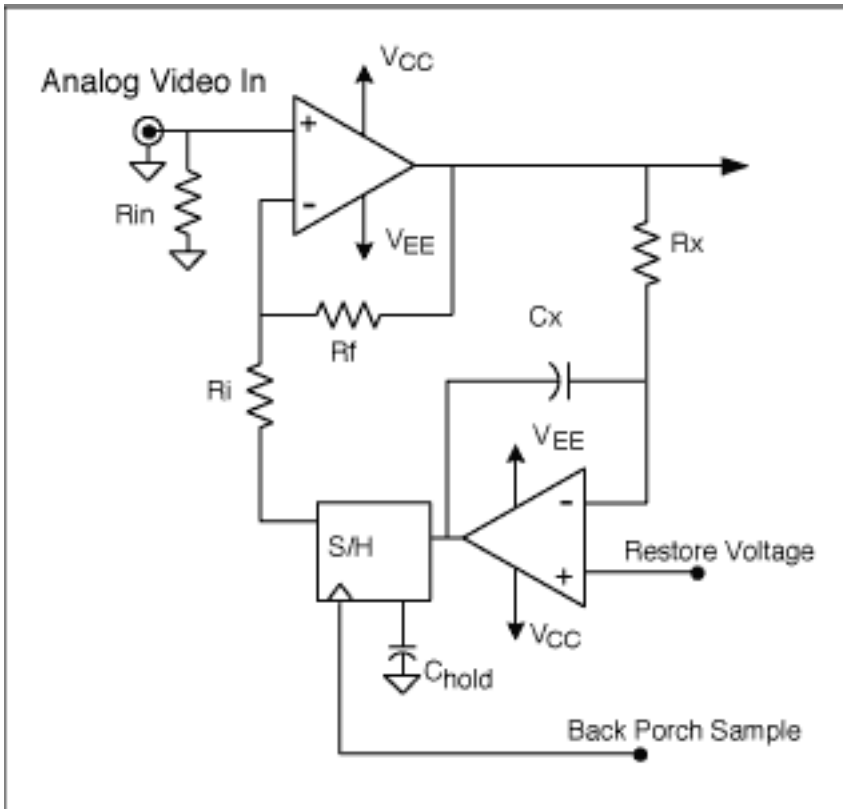

Figure 5. A practical implementation of a dc restore circuit uses two capacitors, two op amps, and an S/H.

The biggest problem with a DC restore is that the level restored—black video to V_{ref} —is analog, and uncorrelated with its value in the digital domain. To correct this, a DAC is often used to generate V_{ref} . Like the keyed clamp, a DC restore can be used on any video signal (with or without sync) and activated anywhere on the waveform—assuming the amplifiers and the S/H are fast enough to follow.

Application Note 3303: www.maxim-ic.com/an3303

More Information

For technical questions and support: www.maxim-ic.com/support

For samples: www.maxim-ic.com/samples

Other questions and comments: www.maxim-ic.com/contact

Keep Me Informed

Preview new application notes in your areas of interest as soon as they are published. Subscribe to [EE-Mail - Application Notes](#) for weekly updates.

Related Parts

MAX4090: [QuickView](#) -- [Full \(PDF\) Data Sheet](#) -- [Free Samples](#)

MAX4399: [QuickView](#) -- [Full \(PDF\) Data Sheet](#) -- [Free Samples](#)

AN3303, AN 3303, APP3303, Appnote3303, Appnote 3303

Copyright © by Maxim Integrated Products

Additional legal notices: www.maxim-ic.com/legal