

APPLICATION NOTE 3291

Using DS4510/DS4520/DS4550 to Select Backup Flash Memory

Many high-reliability systems maintain a backup copy of their flash memory should a new software download become unusable for any reason. This application note describes how the DS4510, DS4520, and DS4550 non-volatile I/O expanders can be used to select the proper page of flash memory on system power-up.

The DS4510, DS4520, and DS4550 are a series of nonvolatile I/O expanders. Since they retain their programmed output values when the system is powered down, they can be used to select the address space of the system or boot flash memory upon system power-up. On system power-up, the outputs of these devices become active as soon as their supply voltage is above 2V.

Many high-reliability and high-availability systems such as servers and communications equipment contain a backup copy of flash memory. Flash memory allows the equipment to be upgraded in the field but there is always a risk that a new software release will have some unintentional consequences or that the new software will become corrupted during loading and unusable. By maintaining the previous software version, the equipment has the option to revert to the older more stable version should problems arise with the new version.

Figure 1 shows how the nonvolatile I/O expanders can be used to select which page of flash memory the system controller should use. The latest software version and the backup copy will be stored in separate pages of the flash memory. For example, a new software load will be loaded into Page 0 when the current software is loaded into Page 1 and vice versa. Once the new software is loaded, the system controller can select the new software by changing the programmed value in the I/O expander and initiating a system re-start.

One key feature of the nonvolatile I/O expanders is that their configuration can be changed without storing the configuration in the nonvolatile memory. This allows the system controller to overwrite the current configuration and try it without disrupting the power-on default state. Hence the system controller can try the new software version and if it fails, upon system power-up, the nonvolatile I/O expanders will retain the old configuration and revert to the older stable software version. When the system controller is sure that it wants to always operate with the newly loaded software, it writes the configuration into nonvolatile memory which will make it the default power-up value. The SEE bit in the DS4510, DS4520, and DS4550 nonvolatile I/O expanders controls this feature. Please see their respective data sheets for more information on the operation of the SEE bit.

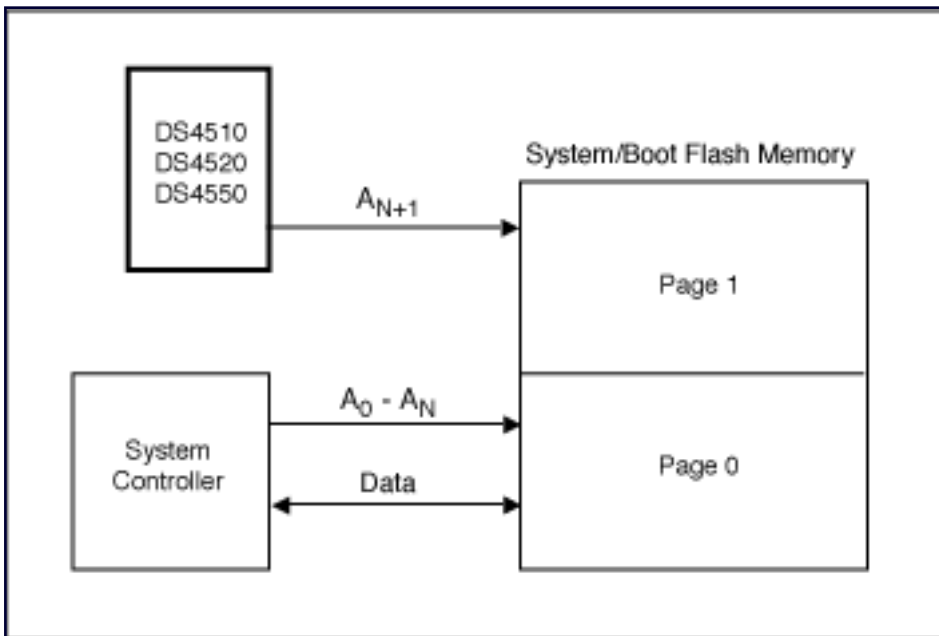

Figure 1. Using nonvolatile I/O expanders to select flash memory.

Application Note 3291: <http://www.maxim-ic.com/an3291>

More Information

For technical questions and support: <http://www.maxim-ic.com/support>

For samples: <http://www.maxim-ic.com/samples>

Other questions and comments: <http://www.maxim-ic.com/contact>

Related Parts

DS4510: [QuickView](#) -- [Full \(PDF\) Data Sheet](#) -- [Free Samples](#)

DS4510: [QuickView](#) -- [Full \(PDF\) Data Sheet](#) -- [Free Samples](#)

DS4520: [QuickView](#) -- [Full \(PDF\) Data Sheet](#) -- [Free Samples](#)

DS4520: [QuickView](#) -- [Full \(PDF\) Data Sheet](#) -- [Free Samples](#)

DS4550: [QuickView](#) -- [Full \(PDF\) Data Sheet](#) -- [Free Samples](#)

DS4550: [QuickView](#) -- [Full \(PDF\) Data Sheet](#) -- [Free Samples](#)

AN3291, AN 3291, APP3291, Appnote3291, Appnote 3291

Copyright © 2005 by Maxim Integrated Products

Additional legal notices: <http://www.maxim-ic.com/legal>