

APPLICATION NOTE 325

# DS2151, DS2152, DS2153, DS2154 Dallas Single Chip Transceiver Crystal Selection Guide

*Abstract: Application Note 325 is a Crystal Selection Guide for these Dallas Single Chip Transceivers: DS2151, DS2152, DS2153, DS2154, DS21552, DS21554, DS21352, DS21354 and DS2155.*

Specifications for selecting the appropriate crystal in a T1 or E1 application are given in the following order.

1. Table 1: DS2155, DS21x5y, DS2154, and DS2152 Crystal Specifications
2. Table 2: Recommended Crystal Manufacturers that meet DS2155, DS21x5y, DS2154, and DS2152 Crystal Specifications
3. Table 3: Oscillator Manufacturers
4. Table 4: DS2151 and DS2153 Crystal Specifications
5. Table 5: Recommended Crystal Manufacturers that meet DS2151 and DS2153 Crystal Specifications

The DS2152, DS2154, DS21x5y, and DS2155 do not require a crystal for most applications. Typically, a clock derived from the system or supplied by an oscillator drives MCLK. If it is not a 1x clock, then appropriate divider can be used to drive the MCLK. For the DS2155, a 16.384MHz, 8.192MHz, 4.096MHz, 2.048MHz, or 1.544MHz clock must be applied at MCLK. ITU specification G.703 requires an accuracy of  $\pm 50\text{ppm}$  for both T1 and E1. TR62411 and ANSI specifications require an accuracy of  $\pm 32\text{ppm}$  for T1 interfaces. A prescaler divides the 16MHz, 8MHz, or 4MHz clock down to 2.048MHz. There is an on-board PLL for the jitter attenuator, which converts the 2.048MHz clock to a 1.544MHz rate for T1 applications. In an application that derives all timing from the network (loop timed), a crystal can be connected to MCLK and XTALD as shown in **Figure 1**. There is no pullability requirement for this crystal.

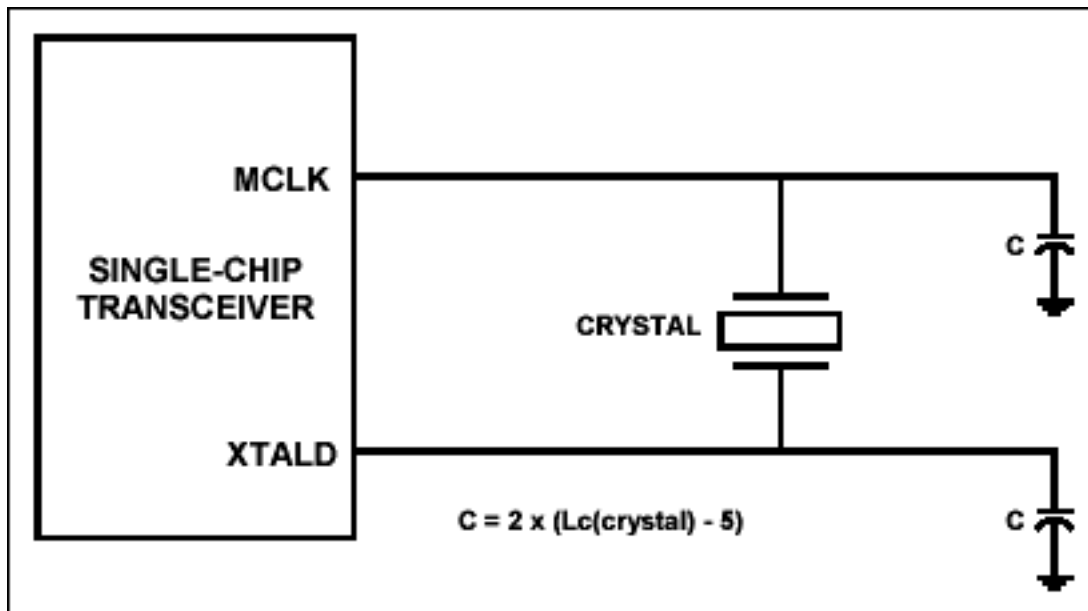

Figure 1. Crystal connection.

Specifications for selecting the appropriate crystal in a T1 or E1 application are given in **Table 1**. A list of crystal manufacturers is in **Table 2**. **Table 5** lists oscillator manufacturers.

**Table 1. DS2155, DS21x5Y, DS2154 and DS2152 Crystal Specifications**

Parameter	Specification
Parallel Resonant Frequency	1.544MHz (T1), 2.048MHz (E1)
Mode	Fundamental
Load Capacitance	See Figure 1
Tolerance	±50ppm
Crystal Cut	AT

**Table 2. Recommended Crystal Manufacturers for DS2155, DS21x5Y, DS2154, and DS2152**

Manufacturer	Address	Part
Saronix	141 Jefferson Drive Menlo Park CA 94025 650-470-7700 or 800-227-8974	<u>Commercial Temp Range</u> (T1, 3.088 MHz) NYP0308-XXGHE(L)* (E1, 4.096 MHz) NYP0409-XXGHE (L)* *Need to use divider for MCLK.
Ecliptek	3545 Cadillac Ave. Costa Mesa, CA 92626-1401 714-433-1200	<u>Commercial Temp Range</u> Crystal available for both T1 and E1 mode of operations.

**Table 3. Recommended Oscillator Manufacturers**

Manufacturer	Address	Part
Saronix	141 Jefferson Drive Menlo Park, CA 94025-1114 650-470-7700 or 800-227-8974	5V 8-Pin DIP SCS-DS-1046 1.544MHz SCS-DS-1047 2.048MHz
		3V 8-Pin DIP SCS-DS-1048 1.544MHz SCS-DS-1049 2.048MHz

The DS2151 and DS2153 require a crystal that can be pulled off its center frequency. Table 5 lists manufacturers. The part numbers given are for leaded packages. Surface-mount devices typically do not meet the pullability specification. Some of the following manufacturers may offer surface-mountable packages in which the leads have been preformed (gull-winged) with a clip added to provide a third contact point.

**Table 4. DS2151 and DS2153 Crystal Specifications**

Parameter	Specification
Parallel Resonant Frequency	6.176 (T1), 8.192 (E1)
Mode	Fundamental
Load Capacitance	18pF to 20pF
Tolerance	±50ppm
Pullability	CL = 10pF, $\Delta f = + 175$ to $+ 250$ ppm CL = 45pF, $\Delta f = + 175$ to $- 250$ ppm
Effective Series Resistance	35 $\Omega$ (max)
Crystal Cut	AT

**Table 5. Recommended Crystal Manufacturers for DS2151 and DS2153**

Manufacturer	Address	Part
M-Tron	100 Douglas Ave. P.O. Box 630 Yankton, SD 57078-0630 605-665-9321 605-665-1709	<u>Commercial Temp Range</u> (T1, 6.176MHz) 4575-032 (E1, 8.192MHz) 4575-031  <u>Industrial Temp Range</u> (T1, 6.176MHz) 4144-002 (E1, 8.192MHz) 4144-001  <b>Note: Do not use MP-1 Prefix</b>
Raltron	2315 N.W. 107th Ave. Miami, FL 33172 305-593-6033 FAX: 305-594-3973	<u>Commercial Temp Range</u> (T1, 6.176MHz) A-6.176-18.5-DS (E1, 8.192MHz) A-8.192-18.5-DS  <u>Industrial Temp Range</u> (T1, 6.176MHz) A-6.176-18.5-DSE (E1, 8.192MHz) A-8, 192-18.5-DSE
Sunny-Emi Co. Suntrac (Dist)	11925 Ventura Blvd. Studio City, CA 91604 818-509-8985	<u>Industrial Temp Range</u> (T1, 6.176MHz) SE 061-32 (E1, 8.192MHz) SE 081-30
JAN	2341 Crystal Dr. P.O. Box 6017 Fort Myers, FL 33906-6017 941-936-2297 FAX: 941-936-3750	<u>Commercial Temp Range</u> (T1, 6.176MHz) JC6B18 (E1, 8.192MHz) JC8B18
Ecliptek	3545 Cadillac Ave. Costa Mesa, CA 92626-1401 714-433-1200	<u>Commercial Temp Range</u> (T1, 6.176MHz) ECX-4173-6.176M (E1, 8.192MHz) ECX-3876-8.192M
Saronix	Strategic Marketing, Inc. 624 W. University Suite 265 Denton, TX 76201	<u>COMMERCIAL TEMP RANGE</u> (T1, 6.176MHz) SRX5310(L) (E1, 8.192MHz) SRX5469(L)

Maxim has qualified a sample of each device from the above manufacturers and has found that the device meets or exceeds our specifications. We do not conduct an ongoing qualification of these manufacturers.

Application Note 325: <http://www.maxim-ic.com/an325>

### More Information

For technical questions and support: <http://www.maxim-ic.com/support>

For samples: <http://www.maxim-ic.com/samples>

Other questions and comments: <http://www.maxim-ic.com/contact>

### Related Parts

DS21352: [QuickView](#) -- [Full \(PDF\) Data Sheet](#) -- [Free Samples](#)

DS21354: [QuickView](#) -- [Full \(PDF\) Data Sheet](#) -- [Free Samples](#)

DS2152: [QuickView](#) -- [Full \(PDF\) Data Sheet](#) -- [Free Samples](#)

DS2154: [QuickView](#) -- [Full \(PDF\) Data Sheet](#) -- [Free Samples](#)

DS2155: [QuickView](#) -- [Full \(PDF\) Data Sheet](#) -- [Free Samples](#)

DS21552: [QuickView](#) -- [Full \(PDF\) Data Sheet](#) -- [Free Samples](#)

DS21554: [QuickView](#) -- [Full \(PDF\) Data Sheet](#) -- [Free Samples](#)

AN325, AN 325, APP325, Appnote325, Appnote 325  
Copyright © by Maxim Integrated Products  
Additional legal notices: <http://www.maxim-ic.com/legal>