

APPLICATION NOTE 3245

Injection Transformers for Closed-Loop DC-DC Converter Network Analysis

Operating a current transformer as a voltage transformer provides a cost-effective alternative to injection transformers sold as test accessories.

Engineering labs often have a network analyzer, but few of them include an injection transformer for closed-loop analysis of dc-dc converters. Agilent sells such transformers as test equipment accessories, but they are expensive. Ridley Engineering and Venable also sell injection transformers. Over-the-counter injection transformers have impressive specifications, but they also have high prices. Remember, they are only transformers. As an alternative, you can obtain a cost-effective injection transformer by operating a current transformer as a voltage transformer.

Wide bandwidth is the most difficult parameter to achieve when designing a transformer. On one hand, low-frequency performance requires a larger core and more turns, which increases the transformer's physical size. High-frequency performance, on the other hand, requires good coupling, small size and minimum turns.

Fortunately, a current transformer is acceptable for most applications. For example, the PE-51687 from Pulse Engineering has a 100-turn primary on a ferrite core and no secondary winding. A hole through the core lets you custom wind any number of secondary turns using stranded wire. The wire serves as a connection to the circuit under test and provides a drive level according to the number of secondary turns.

Because we're building a voltage transformer, we need to control the primary voltage. Given that the transformer's primary reactance is higher than that of the source, connecting a 50Ω resistor in parallel with the primary properly terminates the network-analyzer source. For low frequencies, the primary's inductive reactance must be higher than the Thevenin equivalent as seen by transformer (25Ω). Because the PE-51687 has a primary inductance of 20mH, the lowest frequency at which that transformer should operate is: $X_L = 2 * 3.1416 * \text{Freq} * L_{\text{prim}}$.

Rearranging, $\text{Freq} = 25 / (6.28 * 20\text{mH}) = 200\text{Hz}$.

A low-frequency cutoff of 200Hz is good for small signals, but larger voltages can induce core saturation by exceeding the core's Volt-second rating. The PE-51687 primary specifies $600\text{V} * \text{ms}$ (1V for 600ms). Thus, the drive-voltage level also can limit the low-end frequency response.

High-frequency response is limited by capacitance on the primary. For instance, the PE-51687 response is usable to 5MHz and has a peak beyond this frequency (**Figure 1**). Note that the peak is very large (+15dB) but is reduced by a 22V resistor in parallel with the secondary (**Figure 2**). In most cases, peaking can be avoided by limiting the network analyzer's upper sweep frequency.

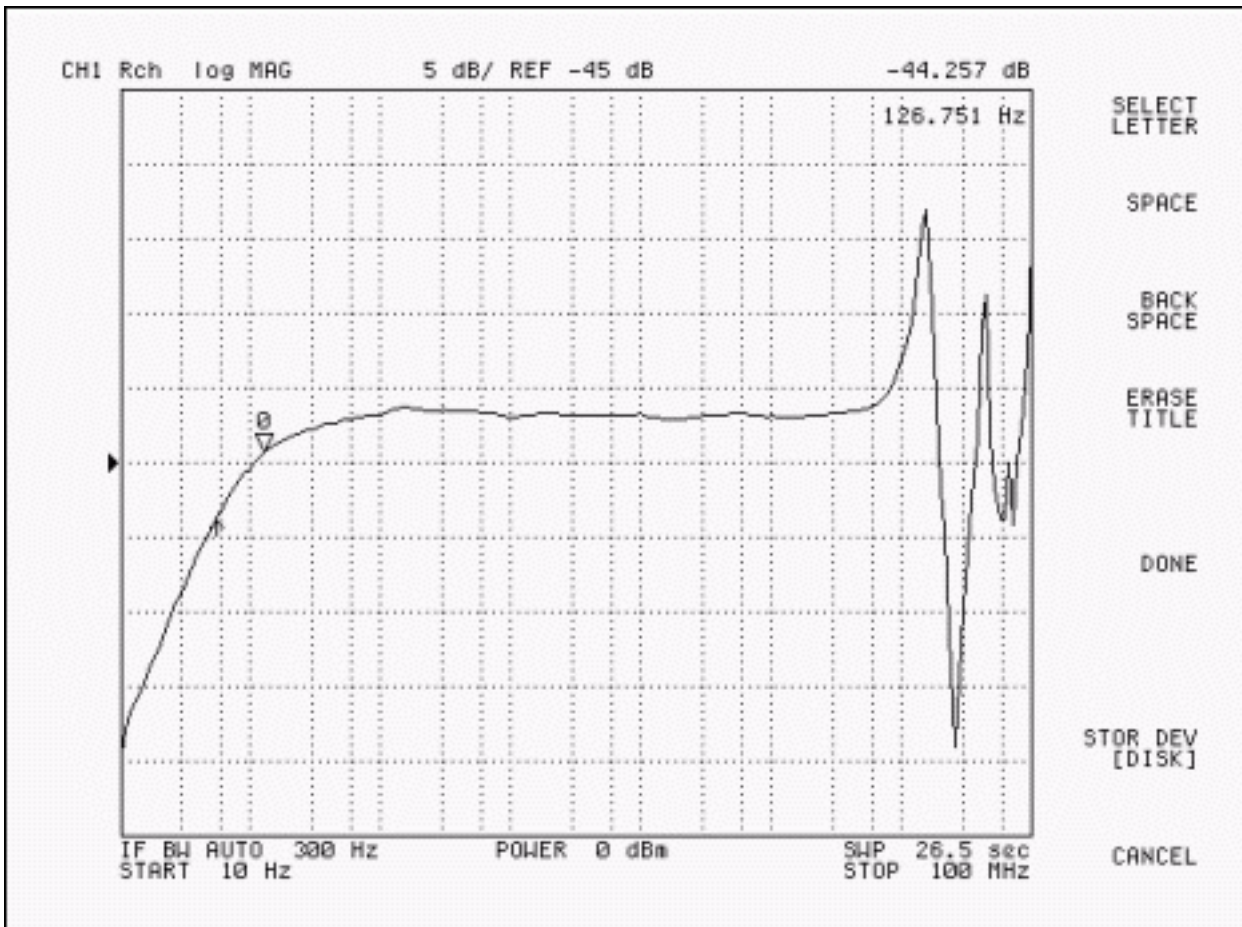

Figure 1. Frequency response of the PE-51687 transformer, with an 8-turn secondary.



Figure 2. Frequency response of the PE-51687 transformer with a 22- Ω resistor on the secondary.

The network plots of Figures 1 and 2 (and later, **Figure 5**) are driven by the network-analyzer source at 0dBm, with the analyzer's 50 Ω inputs buffered with an X10 (-20dB) FET probe, as shown in the test setup of **Figure 3**. The transformer in this test has eight turns of Teflon-insulated 24-AWG wire. (Teflon is useful for circuit hookups because the insulation can withstand soldering temperatures, but any wire is acceptable.) With a turns ratio of 100-to-8, the transformer has -21.9dB of insertion loss. Thus, the measuredValue (-42dBm) includes the FET probe loss.

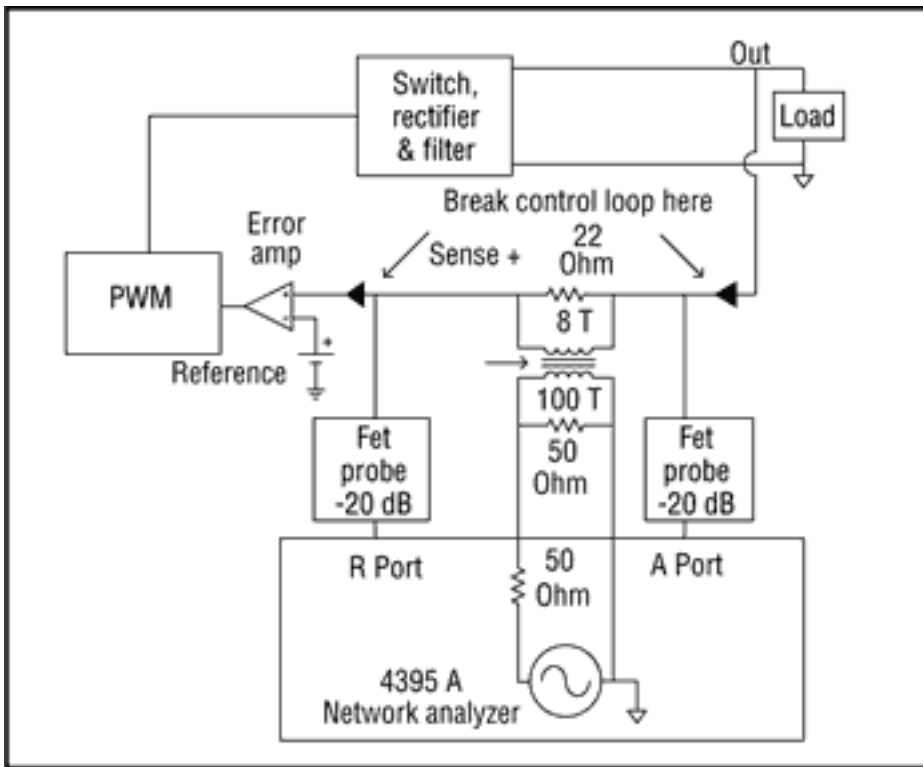

Figure 3. Injection transformer setup for loop-gain measurements.

To test a closed-loop system with an injection transformer, you must break the loop at some point. At that point, the reflected impedance at the network analyzer's A port (Figure 3) should be low, and the impedance reflected on the R port should be high. Those conditions are important, because if the closed-loop gain beyond crossover is much less than one, most of the signal injected by the transformer will show up on the R port.

For example, if the impedance reflected on the R port is only nine times higher than that reflected on the A port, then only one-tenth of the signal will show up on the A port. Nine-tenths will appear on the R port, regardless of the true loop response. That situation requires an impedance buffer (i.e., a FET probe) to raise the network analyzer's input impedance above its inherent 50Ω level.

Loop-gain tests, in some cases, can tolerate a 50Ω load from the network analyzer, but the output impedance in many power supplies is much lower than 50Ω , so loading on the A port is not a problem. Be careful not to overdrive the network analyzer's 50Ω input. Most analyzers limit the input to $5V_{RMS}$, and repairs can be expensive. A FET probe with -20dB attenuation allows most analyzers to measure up to 50V without the use of blocking capacitors.

After configuring the test setup, determine the proper level for signal injection. Network analyzers prefer higher signal levels that get above the noise floor, but the power supply may not behave linearly in response to a large injected signal. In that case, slew rate, current limits or clipping may determine the circuit behavior. Thus, signals slightly larger than the output ripple are recommended.

The PE-51687's 100-to-8 turns ratio can easily provide a signal larger than most output-ripple voltages. For a 0dBm (224 mV_{RMS}) input, the transformer output is 18 mV_{RMS} (50 mV_{p-p})—a good initial level for testing. The network analyzer's output source can adjust the injection level. If that arrangement does not provide adequate range, you can also adjust the drive level by adding or subtracting secondary turns.

For lower-frequency work, the PE-51688 from Pulse Engineering offers a 200-turn primary with 80mH primary inductance, which provides useful signals down to 50Hz. Its Volt-second rating is $1200V \cdot \mu s$. For higher frequencies, the 50-turn PE-51686 is a good choice. For very high frequencies (up to 100MHz), use a Rogowski coil. These high-bandwidth current transformers have internal resistors shunting each winding on the primary,

and a Faraday shield around the primary and core.

The shunt-resistor value times the number of turns produces a near-perfect 50V value, and a resistor on each winding distributes the damping function throughout the transformer. Though expensive, such transformers are almost ring-free, and they can easily provide 100MHz of signal (**Figure 4**). The network plot of **Figure 5** shows a 50-to-1 (1V/A) transformer with single-turn secondary, available from Pearson Electronics or Stangenes Industries Inc.

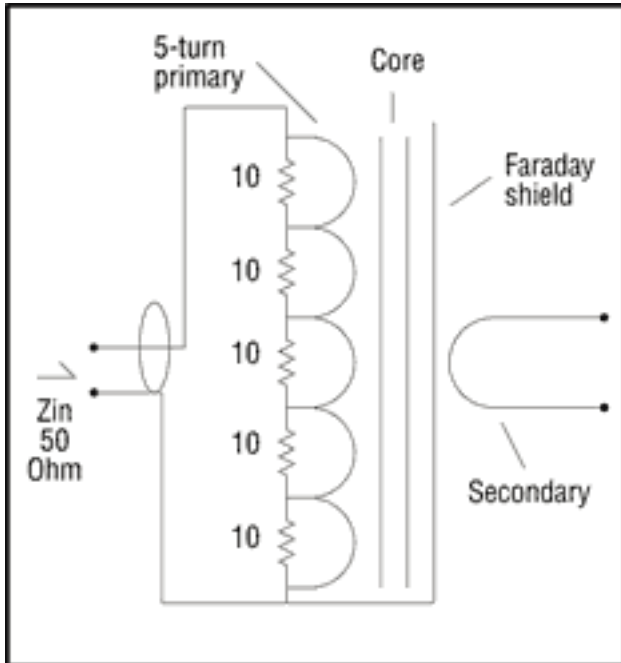

Figure 4. Rogowski current transformer.

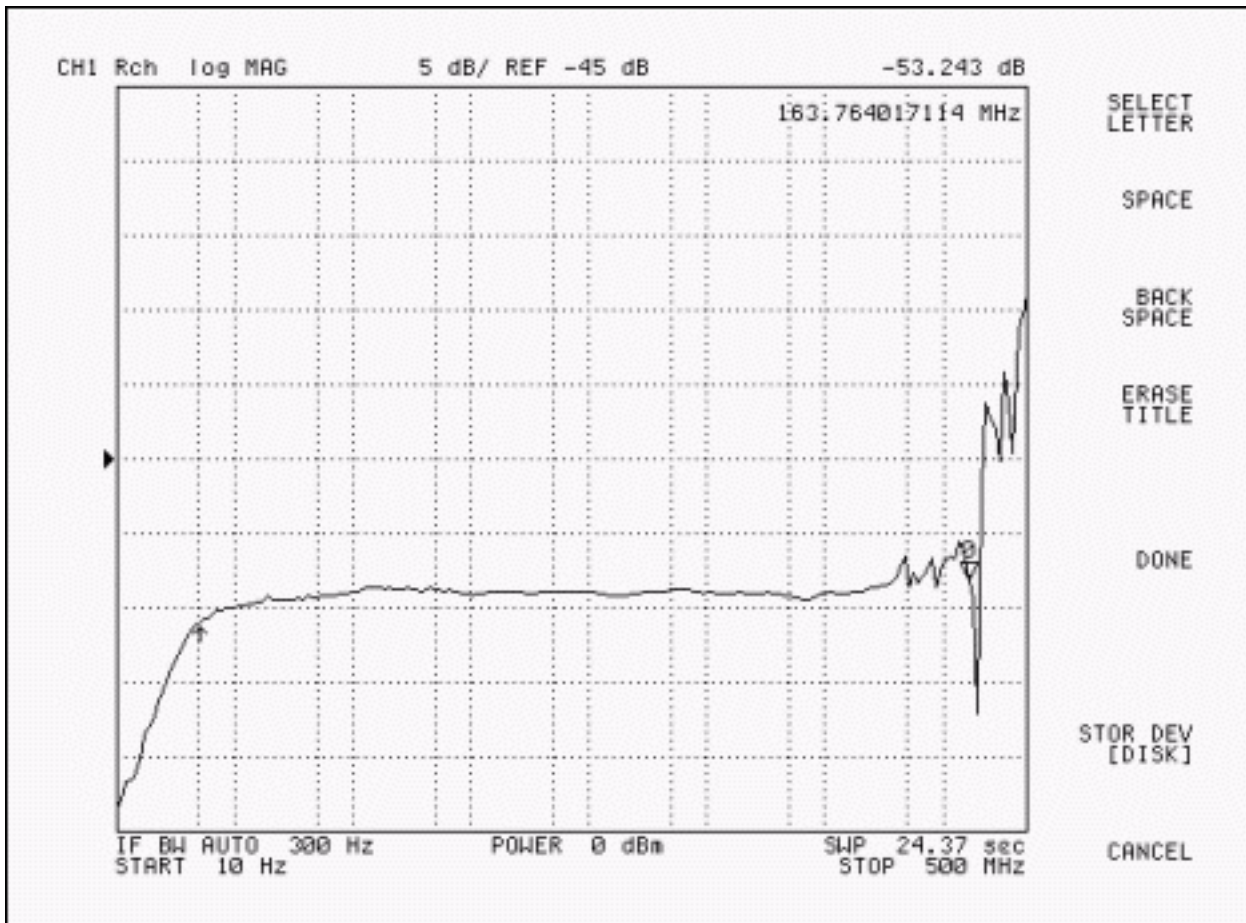

Figure 5. Frequency response of a 1V/A, 50-to-1 Rogowski coil with singleturn secondary.

The main drawback in using current-sensing transformers for signal injection is their poor performance at low frequencies. Most Bode plots are noisy below 50Hz and often exceed 80dB, which stretches the noise-floor limit on most network analyzers. However, most dc-dc systems are well behaved below 50Hz and do not require analysis. If low-frequency measurements are required, you must apply a transformer with a larger core, more turns or both. These changes increase the transformer's physical size, which can be a disadvantage in the test phase. You can also reduce the upper frequency limit: Most systems today have crossover frequencies well above 10kHz, which is ideal for the PE-51687 current transformer.

A similar version of this article appeared in the October 2004 issue of *Power Electronics Technology* magazine.

Application Note 3245: <http://www.maxim-ic.com/an3245>

More Information

For technical questions and support: <http://www.maxim-ic.com/support>

For samples: <http://www.maxim-ic.com/samples>

Other questions and comments: <http://www.maxim-ic.com/contact>

AN3245, AN 3245, APP3245, Appnote3245, Appnote 3245

Copyright © 2005 by Maxim Integrated Products

Additional legal notices: <http://www.maxim-ic.com/legal>