



APPLICATION NOTE 3244

## 3mm-Tall, Dual-Phase, Step-Down, DC-DC Converter Delivers 1.6V at 20A from 12V for Mobile Processor Cores

*Abstract: A dual-output, synchronous buck controller reduces component height in this single output design by splitting the current into two interleaved phases. The dual-phase design reduces the required input filter capacitance and allows each inductor to be shorter than would be possible in a single-phase design. The MAX8537 controller incorporates this design into a 3mm-high circuit that delivers 1.6V at 20A from 12V.*

GPUs in mobile applications require a low-profile core power supply at relatively high current. One approach splits the current into two interleaved phases, which doubles the power circuitry and halves the current for each phase. Splitting the output current between two phases allows each inductor, typically the tallest component, to be shorter, and also reduces the input filter requirements compared to a one-phase design. The main concern with a dual phase approach is current sharing between the two phases.

The MAX8537 dual, synchronous buck controller delivers 1.6V at 20A from 12V,  $\pm 10\%$  input with a 3mm maximum component height (**Figure 1**). The device is intended to provide all three supply rails for DDR memory: VDDQ, VTT, and VTTR. VTT and VTTR must track  $\frac{1}{2}$  of VDDQ. One buck controller on the MAX8537 generates VDDQ; the other buck controller generates VTT and has a reference input to track  $\frac{1}{2}$  of VDDQ. This feature can be used in conjunction with inductor current sensing to combine the two controllers into one output.

Components	Quantity	Description / Part Number
C2,C4	3	Capacitor: Ceramic 10uF/25V, X5R. Taiyo Yuden: TMK325BJ106MM
C5, C6,C7,C10,C45	5	Capacitor: Ceramic 0.1uF /25V, X7R. Murata: GRM39X7R104K25 (0603)
C12	4	Capacitor: Polymer 680uF/2.5V/12 mΩ. Sanyo, 2R5TPE680MCL
C13	1	Capacitor: Ceramic 4.7uF/6V, X5R. Taiyo Yuden: JMK212BJ475MG
C14	1	Capacitor: Ceramic 1uF/35V, X5R.Taiyo Yuden: LMK316BJ105ML (1206)
C15,C16	2	Capacitor: Ceramic 1uF/10V, X5R.Taiyo Yuden: LjMK107BJ105MA (0603)
C17,C43	2	Capacitor: Ceramic 3.9nF /50V, X7R. Murata: GRM39X7R392K50 (0603)
C18,C20,C25	3	Capacitor: Ceramic 10pF/25V, X7R. Murata: GRM39X7R100J50 (0603)
C19,C44	2	Capacitor: Ceramic 330pF/50V, X7R. Murata: GRM39X7R331J50 (0603)
C21	1	Capacitor: Ceramic 6.8nF /50V, X7R. Murata: GRM39X7R682K50 (0603)
C22	1	Capacitor: Ceramic 100pF/50V, X7R. Murata: GRM39X7R101J50 (0603)
C23,C24	2	Capacitor: Ceramic 0.033uF/50V, X7R. Murata: GRM39X7R333K50 (0603)
C39,C40	2	Capacitor: Ceramic 2.2nF /50V, X7R. Murata: GRM39X7R222K50 (0603)
C41,C42	2	Capacitor: Ceramic 0.01uF/50V, X7R. Murata: GRM39X7R103K50 (0603)
D1, D2	2	Diode, Schottky 30V, 100mA. Central CMDSH-3 (SOD-323)
L1,L2	2	Inductor: 0.6uH/10A/6.5mΩ, Toko FDV0630-0R6
N1,N2	2	Transistor, NMOSFET, 30V, 12.5 mΩ. International Rectifier IRF7821 (SO-8)
N3,N4	2	Transistor, NMOSFET: 30V, 4.8mΩ. International Rectifier IRF7832 (SO-8)
R2,R3	2	Resistor: 1.8kΩ, 5% (0603)

R5	1	Resistor: 56k $\Omega$ , 5% (0603)
R6	1	Resistor: 10k $\Omega$ , 5% (0603)
R7,R29,R30,R31,R32	5	Resistor: 2.2 $\Omega$ , 5% (0603)
R8	1	Resistor: 4.7 $\Omega$ , 5% (0603)
R9	1	Resistor: 33.2k $\Omega$ , 1% (0603)
R10,R12,R17,R27	4	Resistor: 22k $\Omega$ , 5% (0603)
R11,R26	2	Resistor: 47k $\Omega$ , 5% (0603)
R13	1	Resistor: 8.2k $\Omega$ , 5% (0603)
R14	1	Resistor: 27k $\Omega$ , 5% (0603)
R15,R16	2	Resistor: 10.0k $\Omega$ , 1% (0603)
R19	1	Resistor: 560k $\Omega$ , 5% (0603)
R21,R22	2	Resistor: 2.2 $\Omega$ , 5%, 0.25 $\Omega$ . (1206)
R24,R25	2	Resistor: 5.1k $\Omega$ , 5% (0603)
R28	1	Resistor: 1k $\Omega$ , 5% (0603)
U1	1	MAX8537 Dual PWM Synchronous Buck Controller (28-QSOP)
U2	1	MAX837 Voltage Monitor (SOT-143)

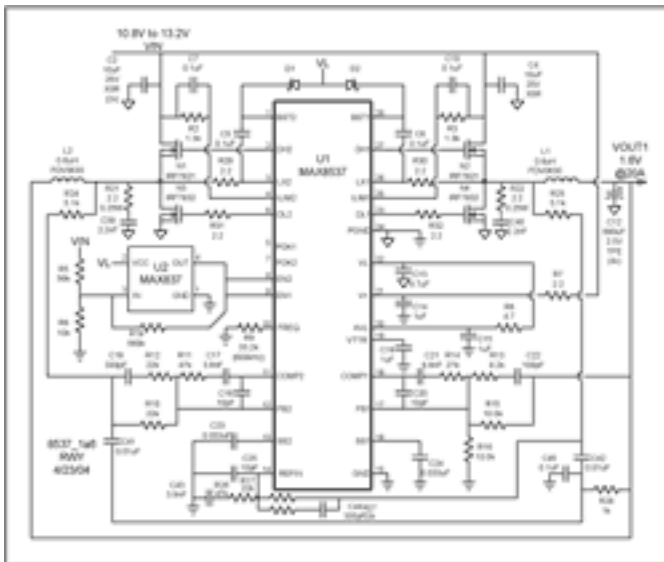

[For Larger Image](#)

Figure 1. MAX8537 Schematic, Data and BOM; 600kHz Dual-Phase Application Circuit: 8537\_1a6

Vin = 10.8V to 13.2V, Vout = 1.6V @ 20A

Date: 4/23/04

VIN1	Iin1	VOUT	IOUT	Efficiency
12.01	0.117	1.602	0	
10.76	3.55	1.602	20	0.839
12.01	3.21	1.603	20	0.832
13.22	2.94	1.603	20	0.825
20MHz BW		<50mVp-p		

Inductor current sensing uses the series resistance of the inductor to sense the inductor current. A series RC in parallel with the inductor matches the time constant of the RL in the inductor. A voltage equal to the inductor current, times the inductor series resistance, appears across the capacitor. The capacitor is referred to the output voltage, therefore the tracking controller can match the output voltage plus a small voltage representing the inductor current in the master controller. The DC current matching depends on the maximum current, the

inductor series resistance, the open-loop gain of the tracking error amplifier, and the matching of the inductor series resistance.

The MAX8537 switching frequency is set to 600kHz, providing a good balance between switching loss and inductor size while considering minimum duty cycle. The master controller is configured to deliver 1.6V at 10A with double the output capacitance to handle 20A step transients. The tracking controller is configured to follow 1.6V with matching compensation networks on both inputs to the error amplifier. The tracking compensation is designed for  $\frac{3}{4}$  of the master controller's loop bandwidth, so the tracking controller follows the master. In addition, C22 is reduced to improve transient response by increasing the master controller phase margin at crossover. R28 and C45 act as a common mode filter for the signals going into the error amplifier. To reduce high-frequency switching noise, R29, R30, R31 and R32 slow switching transitions. R21/C39 and R22/C40 damp parasitic ringing when the high-side switch turns on, so the high-side current limit is not fooled. Current limit is approximately 27A.

This 3mm-tall MAX8537 circuit delivers 1.6V at 20A from 12V input with 83% efficiency. Output ripple is less than 50mVp-p in a 20MHz bandwidth. A step transient from 5.5A to 20A and 20A to 5.5A shows an output voltage response of 140mVp-p and 40usec settling time (**Figure 2**). Current matching error is less than 10%.

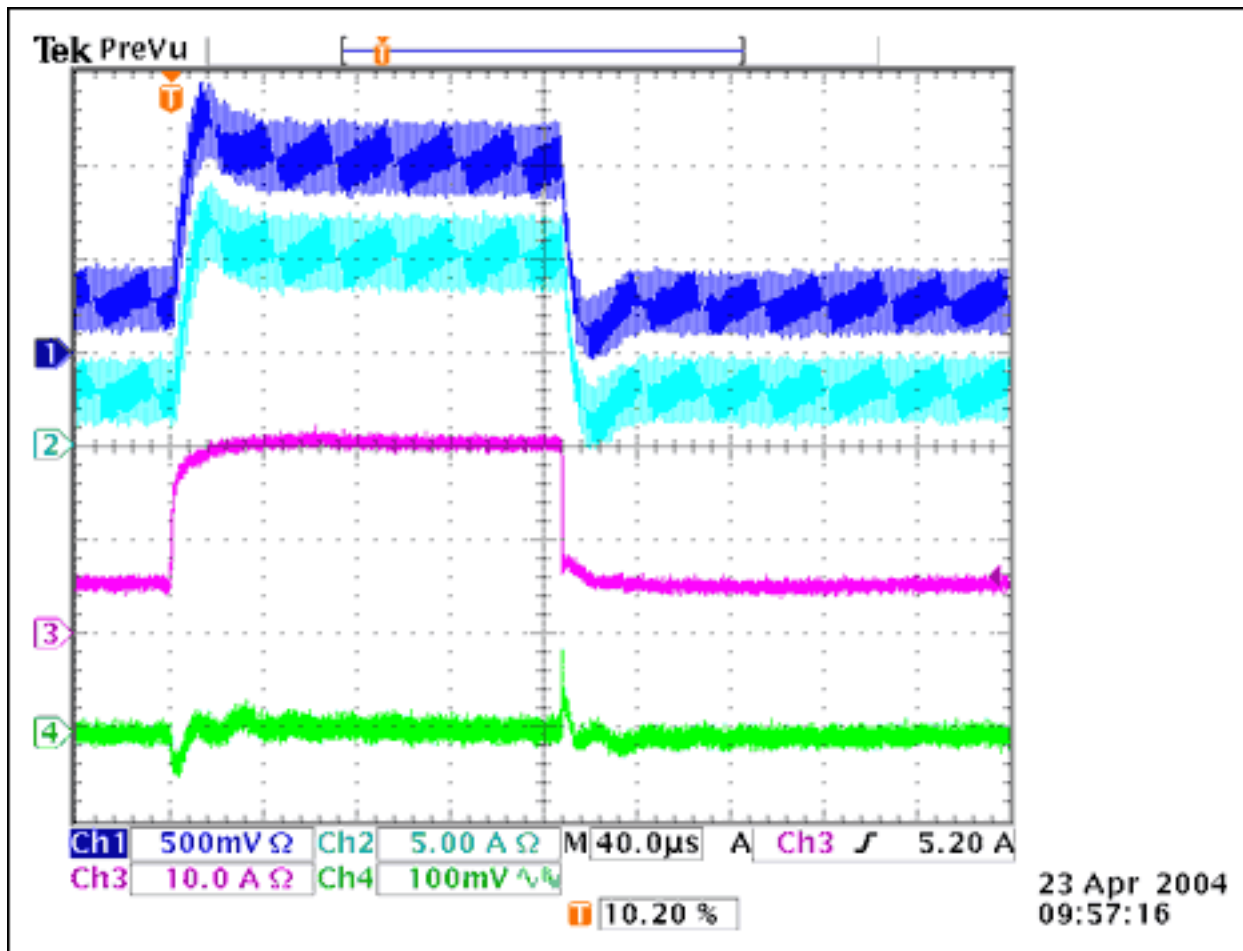

Figure 2. Output transient response.

Application Note 3244: <http://www.maxim-ic.com/an3244>

### More Information

For technical questions and support: <http://www.maxim-ic.com/support>

For samples: <http://www.maxim-ic.com/samples>

Other questions and comments: <http://www.maxim-ic.com/contact>

### Related Parts

MAX8537: [QuickView](#) -- [Full \(PDF\) Data Sheet](#) -- [Free Samples](#)

AN3244, AN 3244, APP3244, Appnote3244, Appnote 3244

Copyright © by Maxim Integrated Products

Additional legal notices: <http://www.maxim-ic.com/legal>