

APPLICATION NOTE 323

DS2151, DS2152, DS2153, DS2154 T1/E1 Line Monitor

Abstract: The DS2151, DS2152, DS2153 and DS2154 single chip transceivers (SCTs) can be used in non-intrusive line monitor applications. Typical monitor ports are isolated from TIP and RING by 470 ohms (T1) resistors. These isolation resistors along with the termination of the monitor (100 ohms, T1) produce about 20dB of resistive loss.

The DS2151, DS2152, DS2153 and DS2154 SCT (Single Chip Transceivers) can be used in a non-intrusive line monitor application. Typical monitor ports are isolated from TIP and RING by 470Ω (T1) resistors as shown in **Figure 1**. These isolation resistors along with the termination of the monitor (100Ω , T1) produce about 20 dB of resistive loss. Using a 1 to 4 step-up transformer, as shown in **Figure 2**, will add about 12 dB of gain bringing the signal level up to a recoverable range. Note that the effective termination resistance is $1/16$ of R_t in Figure 2 due to the transformer. Table 1 gives the Monitor circuit termination resistor values.

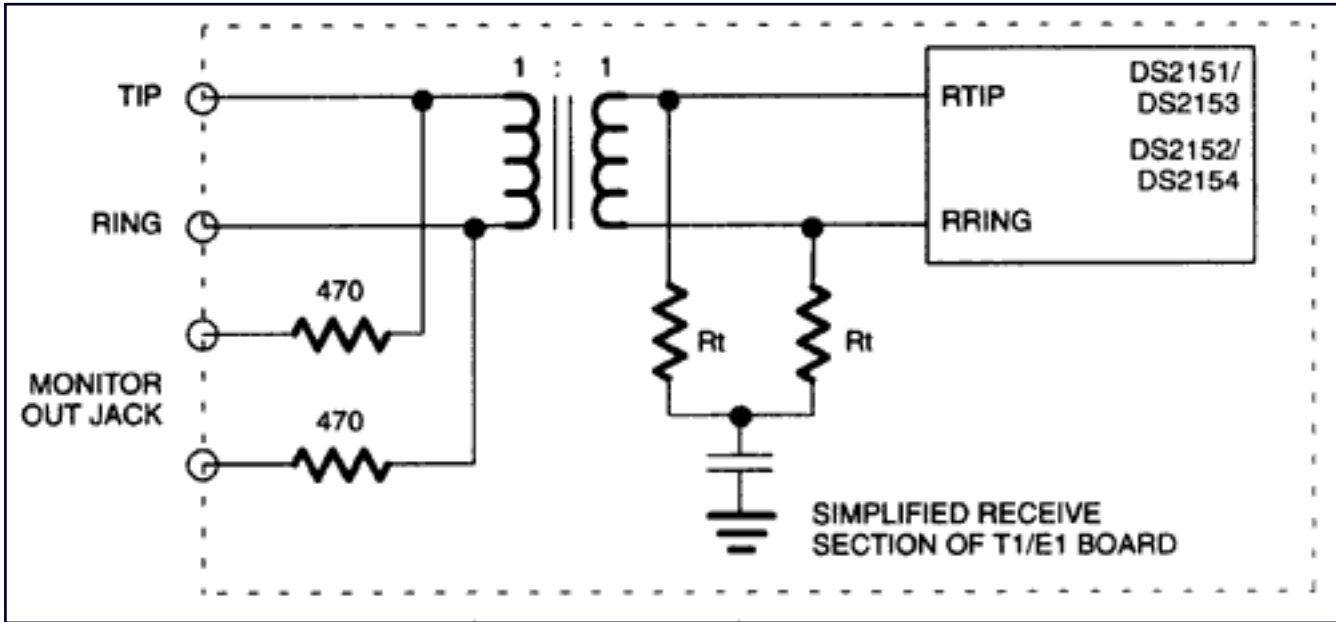

Figure 1. Typical monitor port.

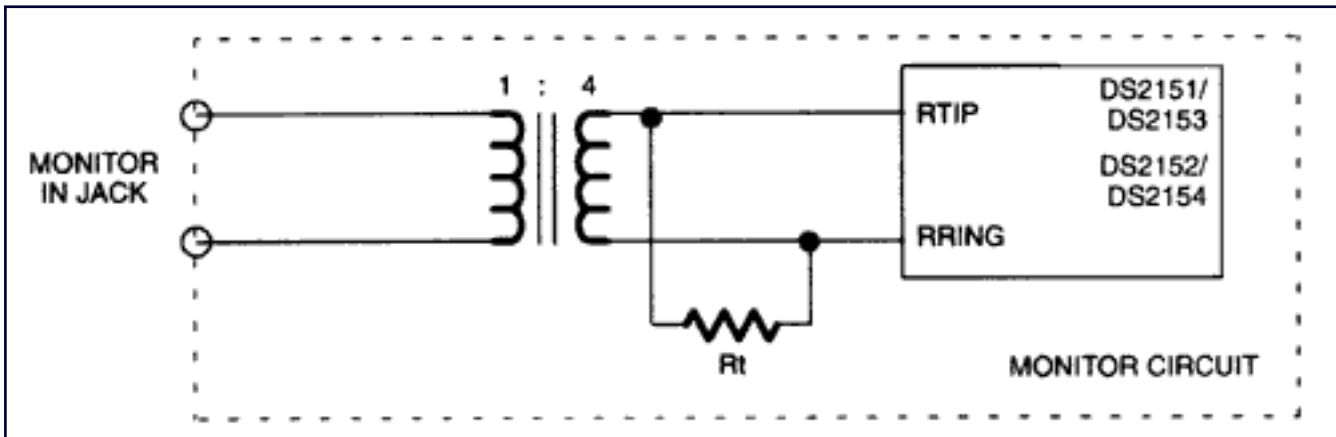

Figure 2. Monitor.

Table 1

Mode	RT	Device
T1	1600 ohms	DS2151, DS2152
E1, 120	1920 ohms	DS2153, DS2154
E1, 75	1200 ohms	DS2153, DS2154

Note: The DS2152 and DS2154 have a mode in which 6 dB of flat gain can be added by setting the 02h bit in register TEST2.

Application Note 323: <http://www.maxim-ic.com/an323>

More Information

For technical questions and support: <http://www.maxim-ic.com/support>

For samples: <http://www.maxim-ic.com/samples>

Other questions and comments: <http://www.maxim-ic.com/contact>

Related Parts

DS2152: [QuickView](#) -- [Full \(PDF\) Data Sheet](#) -- [Free Samples](#)

DS2154: [QuickView](#) -- [Full \(PDF\) Data Sheet](#) -- [Free Samples](#)

AN323, AN 323, APP323, Appnote323, Appnote 323

Copyright © by Maxim Integrated Products

Additional legal notices: <http://www.maxim-ic.com/legal>