

APPLICATION NOTE 3226

High-Level Integration Needed for Compact Digital-Camera Power

Abstract: Digital cameras are rapidly replacing film cameras. The market is expanding as both traditional-camera makers and consumer-electronic makers rapidly introduce products. Power management is particularly difficult in digital cameras because high-speed logic, sensitive CCD imaging, and displays must be efficiently powered at the same time. Of course, power-supply space, weight, and heat are also critical. To enable these designs, advanced PMICs are needed.

A digital camera may require six or more different voltages to operate. These include power to system logic, a low-voltage DSP core, shutter actuators and lens motors, CCD bias, LCD bias, and LCD backlighting. The block diagram of a typical compact digital camera is shown in **Figure 1**. The first generations of power ICs for digital cameras were, and in some cases still are, multichannel PWM controller ICs that operate with external MOSFETs and transformers to generate multiple camera operating voltages. The limitations of those designs are poor efficiency, large numbers of external components, and large circuit size. Though the controller ICs themselves are inexpensive, the total circuit cost can be high, especially if high-performance MOSFETs and transformers are needed to maintain efficiency and not waste the limited battery capacity.

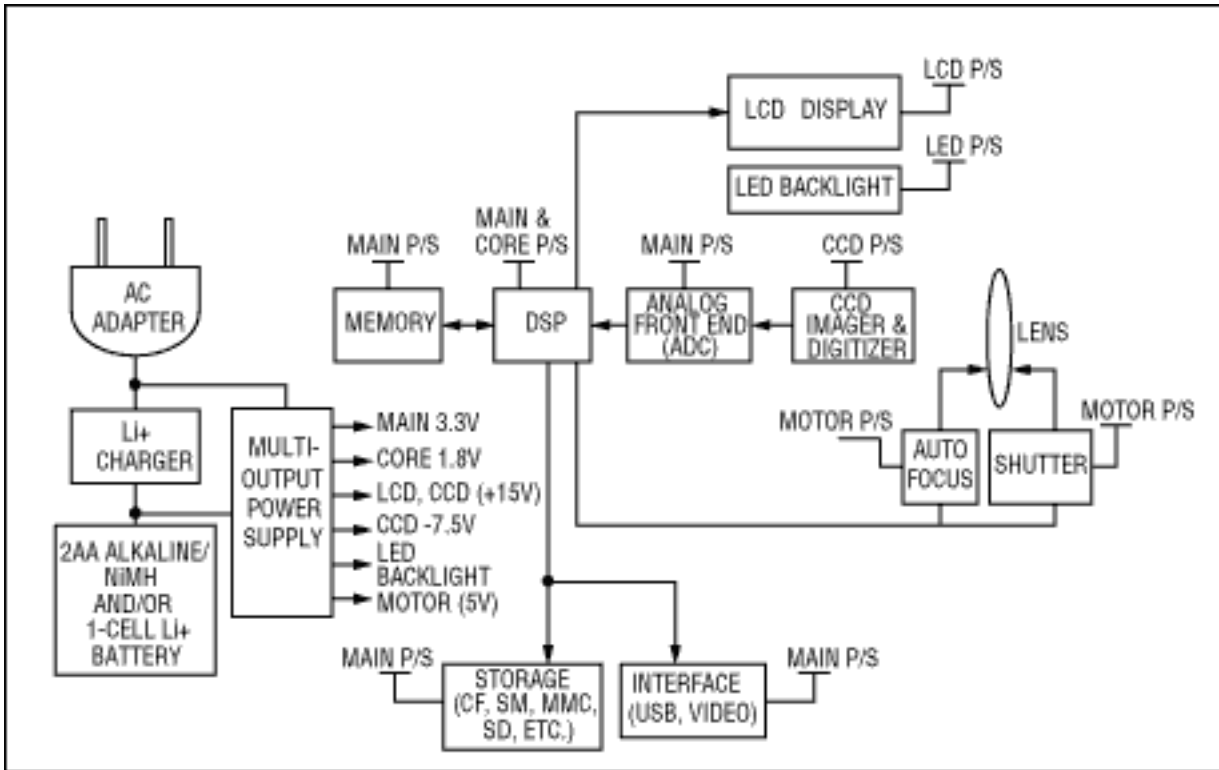

Figure 1. This compact digital-camera block diagram shows various operating voltages.

Advances in Integration

IC process improvements in the last few years have allowed more integration of power switches with other functions. This integration, combined with IC packaging advances, is supplying a new generation of integrated multifunction power ICs. These chips supply all the voltages needed for digital cameras, while offering significant battery-life improvement and major reductions in component count. Especially significant is the elimination of

transformers for many designs. This not only reduces cost, but also speeds design time, because transformers are not typically stocked by vendors. Transformers are custom components that require special ordering—something not required for standard, off-the-shelf inductors.

Besides eliminating transformers, newer power ICs increase operating frequency. This allows reductions in component size, because less energy needs to be stored on each switching cycle if more switching cycles can take place each second. As a result, inductance and filtercapacitor values are lowered and inductor and capacitor size reduced. Another benefit of smaller capacitor values is that, at 500kHz and above, filter values become small enough to allow ceramic capacitors. Ceramic capacitors have proven to be more reliable than polarized types and have very low ESR, which reduces ripple.

Optional Power-IC Design

A typical power supply for a compact or pocket-sized digital camera is shown in **Figure 2**. The multi-output IC combines six DC-DC power converters. One difficulty in developing large ICs for complex systems like digital cameras is that, unlike PCs, digital-camera power supplies are not all exactly alike. Differences in battery, CCD size, display, and functionality all create significant variation in required supply voltages and the power needed from each. Because of this variation from one camera to the next, the optimal power-IC design is a hybrid of internal and external MOSFET converters. On-chip MOSFETs are used for the voltages that consume the most power, while external MOSFET PWM channels retain flexibility for the remaining voltages.

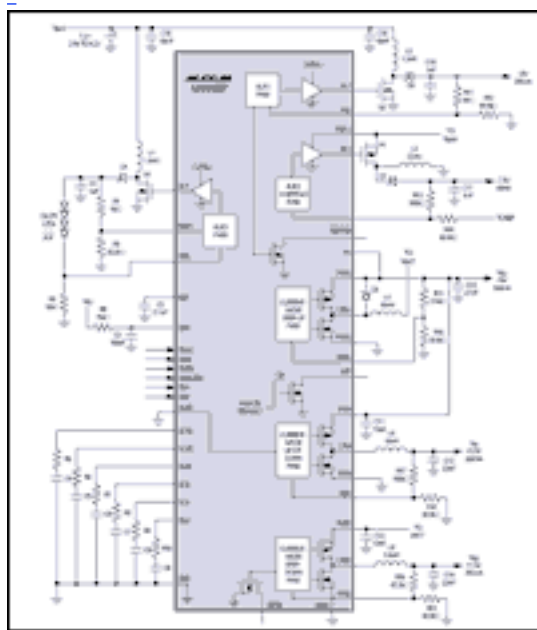

[For Larger Image](#)

Figure 2. This highly integrated power supply for small digital cameras integrates six DC-DC power converters.

The design shown in Figure 2 uses high-efficiency internal MOSFET channels for the camera's main 3.3V logic supply, low-voltage DSP core, and 5V motor supply. These supplies operate for the greatest percentage of time, and/or use the largest amount of battery power. As a result, they benefit the most from the high efficiency afforded by internal MOSFET power switching and synchronous rectification. Power-conversion efficiency for these supplies approaches 95%. Additional voltages for the CCD image sensor, LCD display, and LED backlight vary more from design to design. Consequently, they are good candidates for external-FET channels, which allow optimization for different CCD pixel counts and LCD screen sizes.

For CCD bias, designs commonly use a transformer to generate positive (usually +15V) and negative (-7.5V) outputs. However, transformers are large and cause particular difficulty if height restrictions are imposed. In space-limited designs, like compact cameras, using inductor-based inverters and boost converters is preferred. This is especially true as pixel counts rise to 3MP and above, which increases the required current. Transformer efficiency and size limitations then become even more significant. The design example generates +15V for both LCD and CCD bias with external-FET boost channel (AUX1), and -7.5V for negative CCD bias with an external-FET inverter channel (AUX2).

Compared to higher end models, compact digital cameras tend to economize on features. Nonetheless, smaller pocket cameras are beginning to include larger camera features such as optical zoom, autofocus, and higher pixel resolutions. All these features, particularly mechanical functions that require a motor, like autofocus, typically use 5V power and draw high peak loads of several hundred milliamps or more. Even though the average load on this supply may be only one-tenth of its peak, the momentary peaks are not brief enough to allow use of a low-current power supply and a large capacitor. The capacitor size quickly becomes prohibitive, so the boost converter must be rated for peak motor-load current, which is often as much as 1A. High-power on-chip MOSFETs are needed to supply this load efficiently (up to 95%).

The Buck/Boost Problem

Two battery configurations have emerged as the most popular for small digital cameras. These are 2-cell AA (alkaline or nickel-metal hydride) and 1-cell Li+ batteries. Occasionally, the camera may be designed to operate with both battery configurations. This can be especially challenging for the power-supply designer because, in some cases, the battery must be boosted to generate certain operating voltages (such as 3.3V). In other cases, it must be stepped down to generate that same voltage. This requires a step-up/down (or buck/boost) design. In older camera designs, this was done with flyback (transformerbased) designs that were large, awkward, and fairly inefficient—often no better than 70% efficiency.

Integrated designs with multiple outputs make it easy to create a buck/boost converter, because a step-up supply can be used to power a step-down. This method was not commonly used to solve the buck/boost problem, as it required excellent efficiency from separate buck and boost stages to provide adequate combined efficiency. But now that current-mode step-up and step-down converters can achieve 95%, the combined efficiency reaches 90%, far better than is possible with flyback and SEPIC designs.

When and how stages should be combined for buck-boost operation depends on the battery type. Batteries comprised of two AA cells operate from about 1.8V to 3.6V, while Li+ batteries operate from 2.7V to 4.2V. A Li+-powered design may need a buck/boost converter to generate 3.3V. A design that uses two AA cells may also require a buck/boost converter, as the DSP core (typically 1.5V or 1.8V) supply may not have enough headroom to run from the battery when the cells are severely loaded. In both these cases, efficient buck/boost converters can be made by cascading DC-DC converter stages. A 3.3V supply can be made by first boosting to 5V (V_{SU} 5V, Figure 2), then stepping down to 3.3V (V_M 3.3V, Figure 2). A 1.8V supply can be made the same way by powering the step-down input (PVSD) from 5V. Of course, when using a Li+ cell, the core step-down supply can be powered directly from the battery (as in Figure 2).

Compact digital cameras are likely to have smaller batteries. Of course, high efficiency is needed when smaller batteries are used. Also, smaller batteries cannot supply the same load peaks as their larger counterparts. System power management must frequently turn off unused supplies to extend battery life. When supplies are turned back on, they must not draw large currents that pull the battery voltage down. The integrated supply in Figure 2 ramps up each input at a controlled rate so that each output minimizes input-current surges when activated. This also ensures that outputs rise in a predictable way for sequencing.

Reliability and Safety Enhancement

In addition to providing the necessary voltages with one IC, integrated power circuitry provides advantages for voltage and fault monitoring that would normally require numerous external components. This can be a benefit for both reliability and safety. In Figure 2, three outputs give the status of the three most critical voltages. active-low SDOK provides the status of the supply that powers the DSP core. In some designs, the 3.3V supply to the DSP chip cannot be activated until the DSP core supply is in regulation. active-low SDOK can signal the processor, or directly drive a P-channel MOSFET that gates 3.3V power. active-low AUX1OK can perform the same function for one of the PWM controllers and provide an OK flag for CCD or LCD bias.

A portable device like a compact digital camera is likely to be subjected to harsh conditions. It may be dropped, get wet, or be exposed to extreme temperatures. A powersupply design cannot prevent damage from severe conditions, but it can minimize damage and enhance safety by shutting down when adverse conditions arise. On the other hand, the design must not be too sensitive, otherwise it may shut off during normal load transients. High-level integration supports a high safety level by monitoring all power channels. If any channel is overloaded

or shorted for over 200ms, then all power supplies shut down. The 200ms delay is long enough to allow load transients to occur without false triggering. A fault flag (SCF) can tell the system that a fault has occurred. Additionally, the onchip MOSFETs are protected by thermal shutdown.

Conclusion

Clearly, high-performance power management for small devices, like digital cameras, is best achieved with a high level of integration. Besides the obvious advantage of requiring only one IC, benefits include passive component reductions, significant efficiency improvements, simple implementation of buck/boost topologies, and improved reliability.

Application Note 3226: <http://www.maxim-ic.com/an3226>

More Information

For technical questions and support: <http://www.maxim-ic.com/support>

For samples: <http://www.maxim-ic.com/samples>

Other questions and comments: <http://www.maxim-ic.com/contact>

Related Parts

MAX1566: [QuickView](#) -- [Full \(PDF\) Data Sheet](#) -- [Free Samples](#)

MAX1567: [QuickView](#) -- [Full \(PDF\) Data Sheet](#)

AN3226, AN 3226, APP3226, Appnote3226, Appnote 3226

Copyright © by Maxim Integrated Products

Additional legal notices: <http://www.maxim-ic.com/legal>