

APPLICATION NOTE 3211

# Quick-Start: Driving 14-Segment Displays with the MAX6954

*This article is how-to guide, intended as a quick learning aid for engineers considering using the MAX6954 to drive 14-segment monochrome LEDs.*

The MAX6954 is a versatile display driver, capable of controlling a mix of discrete, 7-segment, 14-segment, and 16-segment LED displays through a serial interface. This application note shows a typical application and configuration for driving eight mono-color, 14-segment LEDs.

See the [MAX6954](#) data sheet for additional information about MAX6954 features.

["Quick-Start: Driving 7-Segment Displays with the MAX6954"](#) and ["Quick-Start: Driving 16-Segment Displays with the MAX6954"](#) are similar application notes that discuss configuring the MAX6954 for 7-segment and 16-segment applications, respectively.

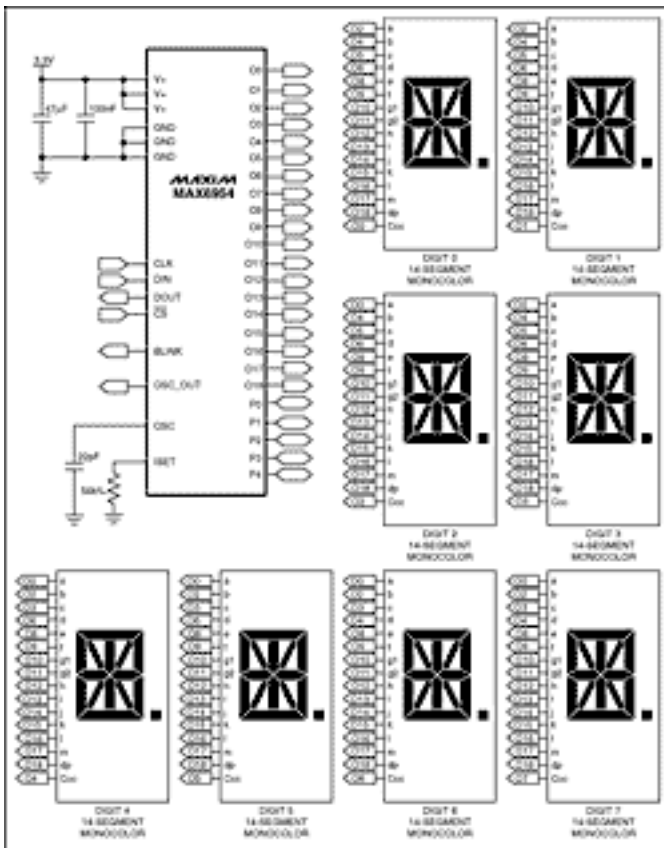

[For Larger Image](#)

Figure 1. MAX6954 14-segment application circuit.

**Table 1. Connection Scheme for Eight 14-Segment Digits**

DIGIT	O0	O1	O2	O3	O4	O5	O6	O7	O8	O9	O10	O11	O12	O13	O14	O15	O16	O17	O18
0	CC0	--	a	--	b	c	d	--	e	f	g1	g2	h	i	j	k	l	m	dp
1	--	CC1	a	--	b	c	d	--	e	f	g1	g2	h	i	j	k	l	m	dp
2	a	--	CC2	--	b	c	d	--	e	f	g1	g2	h	i	j	k	l	m	dp
3	a	--	--	CC3	b	c	d	--	e	f	g1	g2	h	i	j	k	l	m	dp
4	a	--	b	c	CC4	--	d	--	e	f	g1	g2	h	i	j	k	l	m	dp
5	a	--	b	c	--	CC5	d	--	e	f	g1	g2	h	i	j	k	l	m	dp
6	a	--	b	c	d	--	CC6	--	e	f	g1	g2	h	i	j	k	l	m	dp
7	a	--	b	c	d	--	--	CC7	e	f	g1	g2	h	i	j	k	l	m	dp

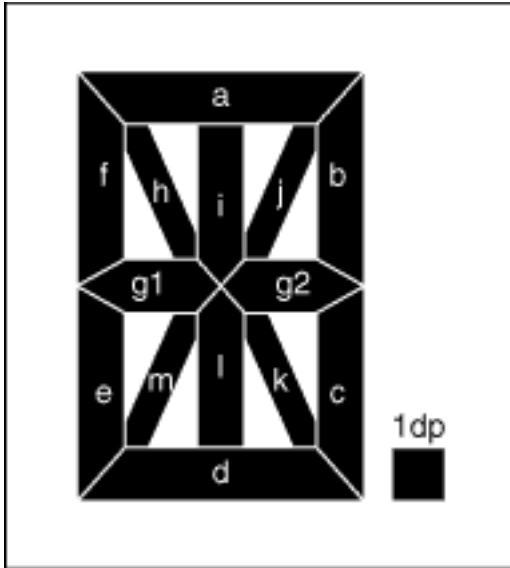

Figure 2. Segment labeling for 14-segment displays.

MSB LSB	x000	x001	x010	x011	x100	x101	x110	x111
0000								
0001								
0010								
0011								
0100								
0101								
0110								
0111								
1000								
1001								
1010								
1011								
1100								
1101								
1110								
1111								

Figure 3. 14-segment display font map.

A common application for the MAX6954 is driving up to eight 14-segment mono-color LEDs. This application note guides the user through the process of connecting the MAX6954 to 14-segment displays and configuring the internal registers to control the displays using the included 104-character font map.

The MAX6954 utilizes a multiplex technique that reduces driver pin count by using ports alternately as cathode and anode drivers. This differs from the standard LED multiplex connection, which uses separate driver pins for anodes and cathodes. The technique is discussed in [AppNote 1880](#). **Table 1** lists the connection scheme for 14-segment digits that is compatible with the MAX6954 multiplex scheme and the built in 104-character font map. The letters in Table 1 correspond to the segment labels shown in **Figure 2**. **Figure 1** illustrates an eight digit, 14-segment application circuit for the MAX6954.

Display test mode can be used to verify connections after connecting the MAX6954 to 14-segment displays. Display test mode overrides, but does not alter, all control and digit registers and turns all segments on. Enable display test mode by writing 0x01 to register 0x07. If a segment does not light in display test mode this indicates a connection problem that should be investigated. Write 0x00 to register 0x07 to exit display test mode.

After verification of the connections between the MAX6954 and the 14-segment displays the device registers must be configured for operation with 14-segment displays. **Table 2** contains a list of the initial power-up states of important MAX6954 registers. When power is first applied to the MAX6954 the device is in shutdown mode, all digits are blanked, and the device is set to scan the maximum eight digits. Configure the MAX6954 for 14-segment operation by writing 0xFF to register 0x0C. The default decode mode (0x01) register setting is correct for 14-segment applications.

**Table 2. MAX6954 Initial Power-Up Register Status**

REGISTER	POWER-UP CONDITION	ADDRESS (HEX)	REGISTER DATA							
			D7	D6	D5	D4	D3	D2	D1	D0
Decode Mode	Font map enabled	0x01	1	1	1	1	1	1	1	1
Global Intensity	1/16 (minimum intensity)	0x02	X	X	X	X	0	0	0	0
Scan Limit	Display eight digits: 0, 1, 2, 3, 4, 5, 6, 7	0x03	X	X	X	X	X	1	1	1
Control Register	Shutdown enabled, blink disabled, blink speed is slow	0x04	0	0	X	X	0	0	0	0
Display Test	Normal operation (display test disabled)	0x07	X	X	X	X	X	X	X	0
Digit Type	Digits 0 through 7 are 16 segment digits	0x0C	0	0	0	0	0	0	0	0
Intensity10	1/16 (min on), digits 1 and 0	0x10	0	0	0	0	0	0	0	0
Intensity32	1/16 (min on), digits 3 and 2	0x11	0	0	0	0	0	0	0	0
Intensity54	1/16 (min on), digits 5 and 4	0x12	0	0	0	0	0	0	0	0
Intensity76	1/16 (min on), digits 7 and 6	0x13	0	0	0	0	0	0	0	0
Digit 0	Blank digit, both planes	0x60	0	0	1	0	0	0	0	0
Digit 1	Blank digit, both planes	0x61	0	0	1	0	0	0	0	0
Digit 2	Blank digit, both planes	0x62	0	0	1	0	0	0	0	0
Digit 3	Blank digit, both planes	0x63	0	0	1	0	0	0	0	0
Digit 4	Blank digit, both planes	0x64	0	0	1	0	0	0	0	0
Digit 5	Blank digit, both planes	0x65	0	0	1	0	0	0	0	0
Digit 6	Blank digit, both planes	0x66	0	0	1	0	0	0	0	0
Digit 7	Blank digit, both planes	0x67	0	0	1	0	0	0	0	0

The configuration register (0x01) is used to enter and exit shutdown, control the blink function, globally clear the

digit data and to select between global or digit-by-digit control of intensity. The configuration register contains 7 bits (**Table 3**):

- S bit selects shutdown or normal operation (read/write).
- B bit selects the blink rate (read/write).
- E bit globally enables or disables the blink function (read/write).
- T bit resets the blink timing (data is not stored—transient bit).
- R bit globally clears the digit data for both planes P0 and P1 for ALL digits (data is not stored—transient bit).
- I bit selects between global or digit-by-digit control of intensity (read/write).
- P bit returns the current phase of the blink timing (read only—a write to this bit is ignored).

Enable the display driver with global intensity control and without blinking by writing 0x01 to register 0x04. The internal oscillator powers as the MAX6954 exits shutdown and the oscillator output is available at OSC\_OUT. Notice that the 14-segment displays remain blank, as the power-up state of digit control registers 0x60 to 0x67 is 0x20 or no segments lit (see Table 2 and **Figure 3**).

**Table 3. Configuration Register Format**

CONFIGURATION REGISTER DATA BIT	DATA BIT LABEL	STATE	FUNCTION
D7	P	0	P1 Blink Phase
		1	P0 Blink Phase
D6	I	0	Intensity for all digits is controlled by one setting in the Global Intensity Register
		1	Intensity for digits is controlled by the individual settings in the Intensity10 through Intensity76 registers.
D5	R	0	Digit data for both planes P0 and P1 are unaffected
		1	Digit data for both planes P0 and P1 are cleared on the rising edge of /CS\
D4	T	0	Blink timing counters are unaffected.
		1	Blink timing counters are reset on the rising edge of /CS\.
D3	E	0	Blink function disabled
		1	Blink function enabled
D2	B	0	Slow Blinking. Segments blink on for 1s, off for 1s with $f_{OSC} = 4\text{MHz}$ .
		1	Fast Blinking. Segments blink on for 0.5s, off for 0.5s with $f_{OSC} = 4\text{MHz}$ .
D1	X	X	Don't care
D0	S	0	Shutdown
		1	Normal Operation

**Table 4. Example Configurations for Display Digit Combinations**

DIGIT TYPE REGISTER SETTING	ADDRESS CODE (HEX)	REGISTER DATA							
		D7	D6	D5	D4	D3	D2	D1	D0

Digits 7-0 are 14-segment digits	0x0C	1	1	1	1	1	1	1	1
----------------------------------	------	---	---	---	---	---	---	---	---

The MAX6954 includes a 104-character ASCII font map for 14-segment displays. The characters follow the standard ASCII font, with the addition of the following common symbols: £, €, ¥, °, μ, ±, ↑, and ↓. Seven bits represent the 104-character font map; an 8th bit is used to select whether the decimal point (DP) is lit (**Table 5**). Digit registers are implemented with two planes, P0 and P1. Each digit is represented by 2 bytes of memory, 1 byte in plane P0 and the other in plane P1 (see **Table 8**). The digit registers are mapped so that a digit's data can be updated in plane P0 (registers 0x20 through 0x27), plane P1 (registers 0x40 through 0x47), or both planes simultaneously (registers 0x60 through 0x67). The data in the digit registers does not control the digit segments directly for 16-segment displays. Instead, the register data is used to address a character generator that stores the data for the 14-segment font (Figure 3). The lower 7 bits of the digit data (D6 to D0) select the character from the font. The most significant bit of the register data (D7) controls the DP segment of the digits; it is set to 1 to light DP, and to 0 to leave DP unlit.

**Table 5. Digit Type Data Register Format**

MODE	ADDRESS CODE (HEX)	REGISTER DATA							
		D7	D6	D5	D4	D3	D2	D1	D0
14-segment mode, writing digit data to use font map data with decimal place unlit	0x20 to 0x27 0x40 to 0x47 0x60 to 0x67	0	Bits D6 to D0 select font character 0 to 127						
14-segment mode, writing digit data to use font map data with decimal place lit	0x20 to 0x27 0x40 to 0x47 0x60 to 0x67	1	Bits D6 to D0 select font character 0 to 127						

If the blink function is disabled through the Blink Enable Bit E (Table 3) in the configuration register, then the digit register data in plane P0 is used to multiplex the display. The digit register data in P1 is not used. If the blink function is enabled, then the digit register data in both plane P0 and plane P1 are alternately used to multiplex the display. Blinking is achieved by multiplexing the LED display using data plane P0 and plane P1 on alternate phases of the blink clock.

As an example let's display eight characters, "MAXIM-IC," using the MAX6954. We disabled the blink functionality when we programmed the configuration register, so data can be written to the 0x20 through 0x27 registers to control digit 0 through digit 7, respectively. Using the font map in Figure 3 determine the code equivalent for each character:

**Table 6. MAXIM-IC Example**

REGISTER ADDRESS (HEX)	DIGIT	CHARACTER	FONT MAP EQUIVALENT CODE	
			DECIMAL	HEX
0x20	0	M	0100 1101	0x4D
0x21	1	A	0100 0001	0x41
0x22	2	X	0101 1000	0x58
0x23	3	I	0100 1001	0x49
0x24	4	M	0100 1101	0x4D
0x25	5	-	0010 1101	0x2D
0x26	6	I	0100 1001	0x49
0x27	7	C	0100 0011	0x43

Adjust the intensity of the displays by writing to register 0x02, the global intensity control register. Intensity may be adjusted between 0x00 (minimum on, 1/16 current) and 0xFF (maximum on, 15/16 current). Digital control of display brightness can also be managed individually for each digit. For full details about adjusting digit intensity and other advanced features such as GPIO and key-scan refer to the MAX6954 data sheet.

**Table 7. Quick-Start Example Command Summary**

REGISTER (HEX)	COMMAND (HEX)	FUNCTION
0x07	0x01	Enter display test mode
0x07	0x00	Exit display test mode
0x0C	0xFF	Set all eight digits to use the 14-segment font map
0x04	0x01	Exit shutdown mode, disable blinking and select global intensity control
0x20	0x4D	Write "M" to digit 0
0x21	0x41	Write "A" to digit 1
0x22	0x58	Write "X" to digit 2
0x23	0x49	Write "I" to digit 3
0x24	0x4D	Write "M" to digit 4
0x25	0x2D	Write "-" to digit 5
0x26	0x49	Write "I" to digit 6
0x27	0x43	Write "C" to digit 7
0x02	0xFF	Set global intensity to full-scale

**Table 8. Partial MAX6954/MAX6955 Register Address Map**

REGISTER	ADDRESS (COMMAND BYTE)								ADDRESS (HEX CODE)
	D15	D14	D13	D12	D11	D10	D9	D8	
Decode Mode	R/W	0	0	0	0	0	0	1	0x01
Global Intensity	R/W	0	0	0	0	0	1	0	0x02
Scan Limit	R/W	0	0	0	0	0	1	1	0x03
Configuration	R/W	0	0	0	0	1	0	0	0x04
Display Test	R/W	0	0	0	0	1	1	1	0x07
Digit Type	R/W	0	0	0	1	1	0	0	0x0C
Intensity 10	R/W	0	0	1	0	0	0	0	0x10
Intensity 32	R/W	0	0	1	0	0	0	1	0x11
Intensity 54	R/W	0	0	1	0	0	1	0	0x12
Intensity 76	R/W	0	0	1	0	0	1	1	0x13
Digit 0 Plane PO	R/W	0	1	0	0	0	0	0	0x20
Digit 1 Plane PO	R/W	0	1	0	0	0	0	1	0x21
Digit 2 Plane PO	R/W	0	1	0	0	0	1	0	0x22
Digit 3 Plane PO	R/W	0	1	0	0	0	1	1	0x23
Digit 4 Plane PO	R/W	0	1	0	0	1	0	0	0x24

Digit 5 Plane P0	R//W\	0	1	0	0	1	0	1	0x25
Digit 6 Plane P0	R//W\	0	1	0	0	1	1	0	0x26
Digit 7 Plane P0	R//W\	0	1	0	0	1	1	1	0x27
Digit 0 Plane P1	R//W\	1	0	0	0	0	0	0	0x40
Digit 1 Plane P1	R//W\	1	0	0	0	0	0	1	0x41
Digit 2 Plane P1	R//W\	1	0	0	0	0	1	0	0x42
Digit 3 Plane P1	R//W\	1	0	0	0	0	1	1	0x43
Digit 4 Plane P1	R//W\	1	0	0	0	1	0	0	0x44
Digit 5 Plane P1	R//W\	1	0	0	0	1	0	1	0x45
Digit 6 Plane P1	R//W\	1	0	0	0	1	1	0	0x46
Digit 7 Plane P1	R//W\	1	0	0	0	1	1	1	0x47

---

Application Note 3211: <http://www.maxim-ic.com/an3211>

### More Information

For technical questions and support: <http://www.maxim-ic.com/support>

For samples: <http://www.maxim-ic.com/samples>

Other questions and comments: <http://www.maxim-ic.com/contact>

### Related Parts

MAX6954: [QuickView](#) -- [Full \(PDF\) Data Sheet](#) -- [Free Samples](#)

MAX6955: [QuickView](#) -- [Full \(PDF\) Data Sheet](#) -- [Free Samples](#)

AN3211, AN 3211, APP3211, Appnote3211, Appnote 3211

Copyright © 2005 by Maxim Integrated Products

Additional legal notices: <http://www.maxim-ic.com/legal>