

#### APPLICATION NOTE 3209

## Protecting Against Momentary Power Loss Due to Battery-Bounce

*Impact or vibration can cause momentary interruptions when batteries lose contact. To ensure continuity of power in battery-powered systems, add this three-IC circuit.*

When you drop a battery-powered device, the impact can open internal contacts for as long as 10ms, producing a momentary loss of power that can cause a false low-battery indication. (There is sometimes a similar momentary effect on the device's owner, especially if the device is expensive, but that's beyond the scope of this application note).

You can insure continuity of power by adding a large capacitor across the battery. The capacitor must provide a certain amount of voltage headroom as margin against the discharge of load current. The capacitor voltage varies with discharge current as  $dV = Idt/C$ , so insufficient headroom calls for an even larger capacitor.

Another problem is that large capacitors tend to be leaky. Capacitor leakage is usually not a problem during normal operation, but during "sleep mode" it can be a substantial fraction of the total quiescent current and can cause a significant reduction in battery life.

The circuit of **Figure 1** solves all these problems. Two AA batteries provide 3V power, which is boosted to 3.3V by a stepup dc-dc converter (U3). The large reserve capacitor of 2mF or 4mF is charged from the 3.3V output via a SPST CMOS analog switch (U1). The output of this 175 $\Omega$  switch charges the reserve capacitor and drives the input of a low-dropout linear regulator (U2).

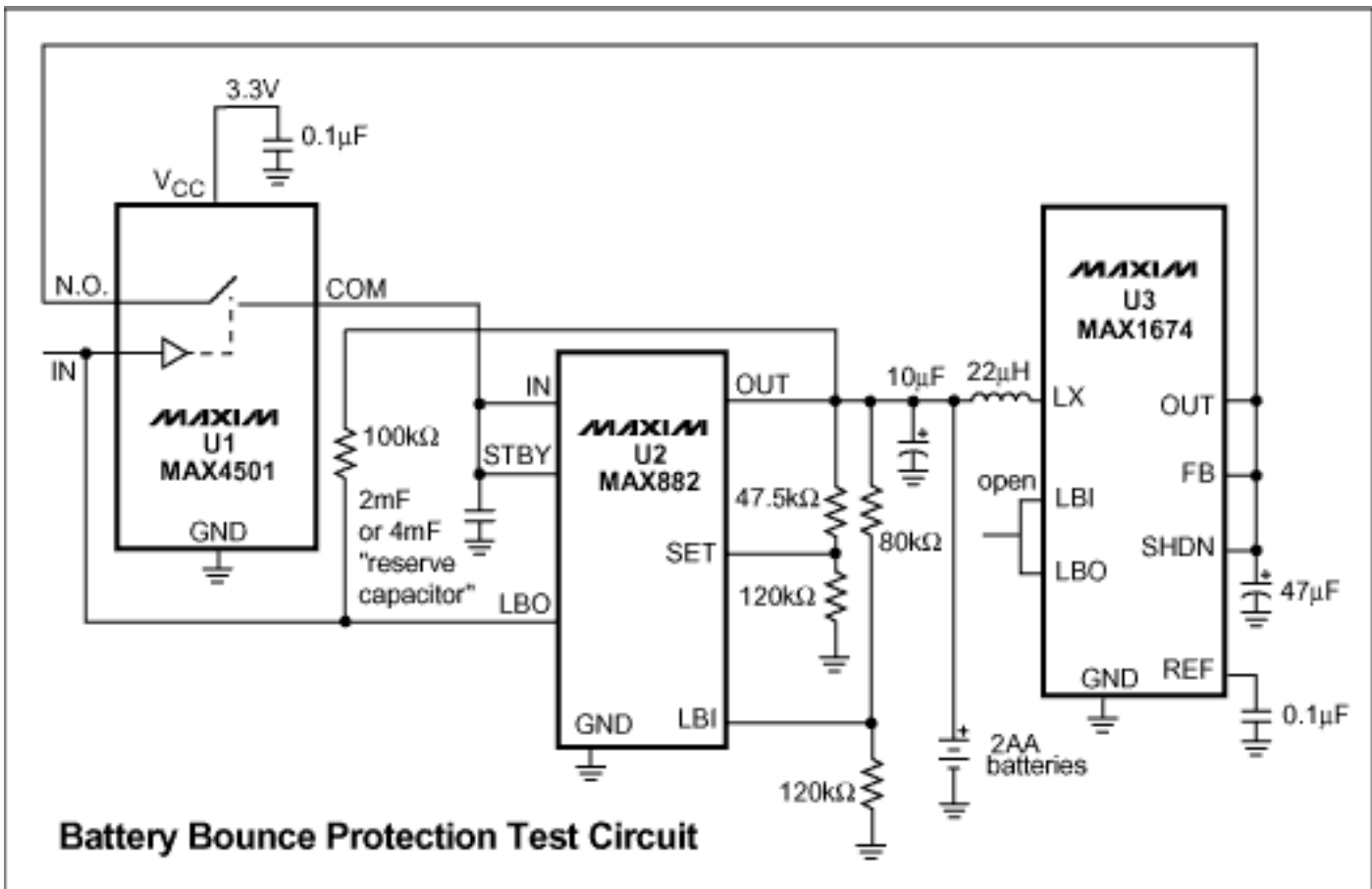

Figure 1. This circuit removes discontinuities in power by backing up the battery (two AA cells) with charge on a reserve capacitor.

U2's output is set to provide 1.68V when the battery is removed. The output is also divided down by the 80k/120k divider to trip an internal comparator connected to the low-battery input (LBI). The comparator's open-drain output (LBO) feeds back to U1's digital input (DIN), which turns the switch on (high) and off (low).

**Figures 2-5** show the circuit performance for different values of reserve capacitor and load current. Figures 5-6 remove switch-response time by wiring the switch in the ON position.

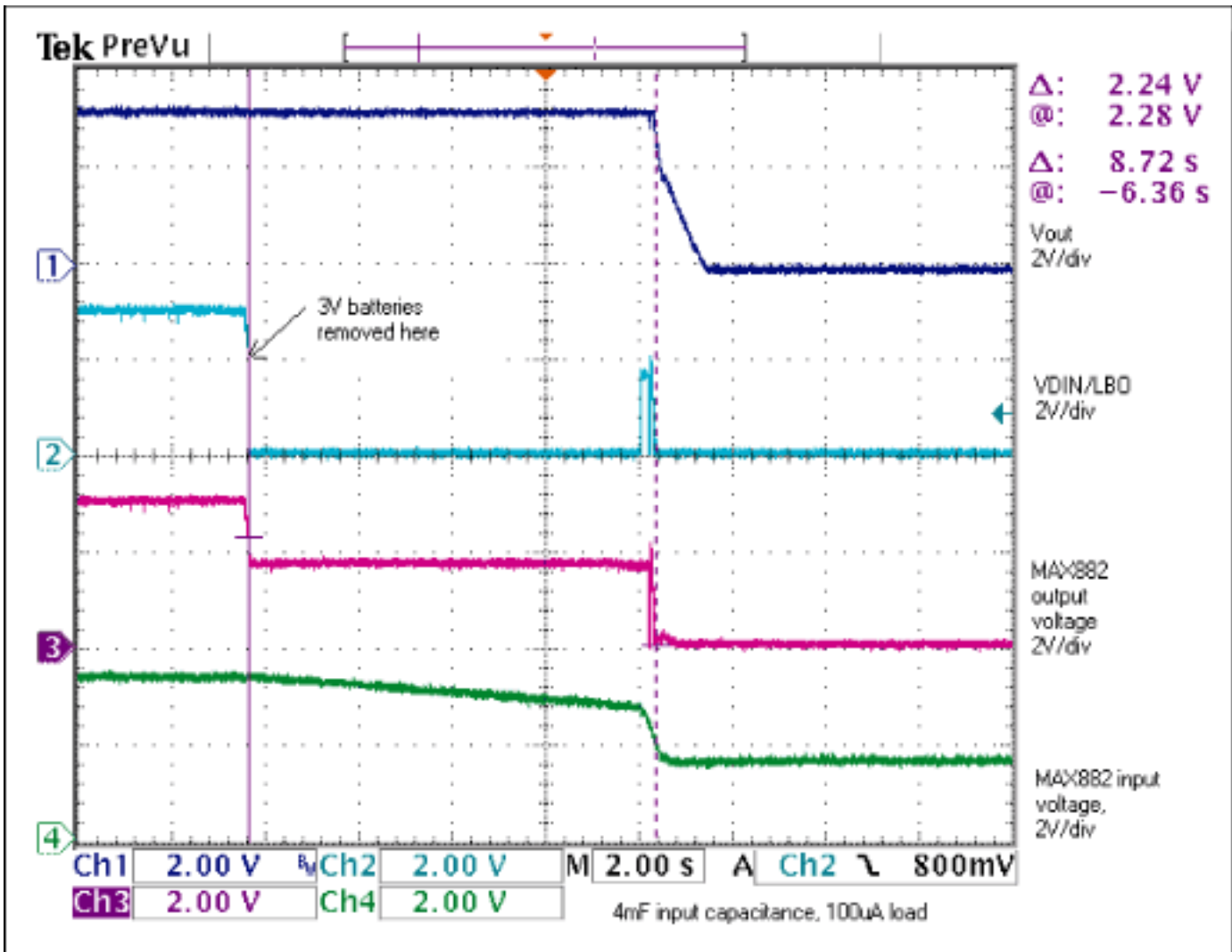

Figure 2. Figure 1 circuit with 4mF reserve capacitor and 100μA load: after removing the battery, power remains for 8.7s.

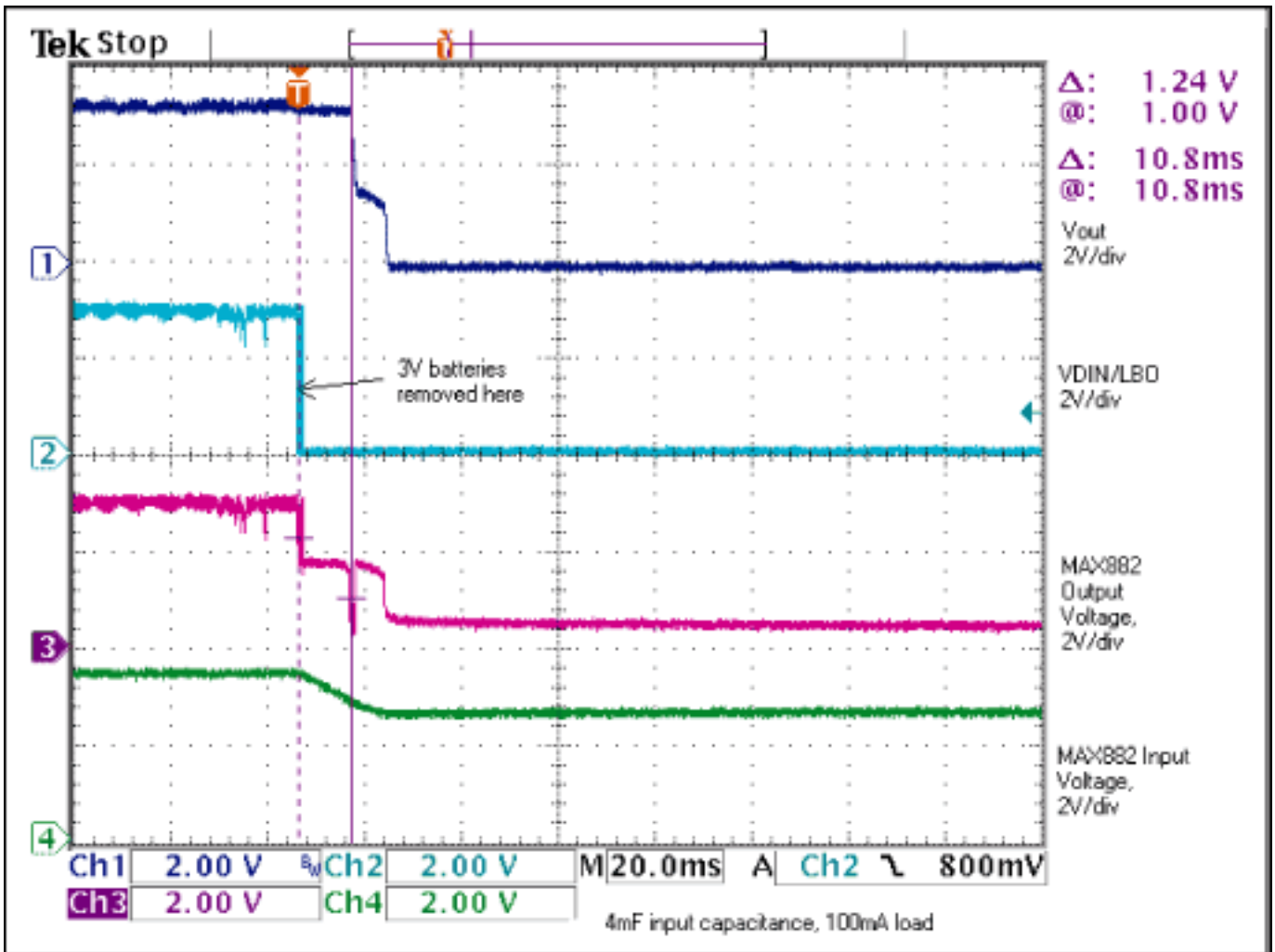

Figure 3. Figure 1 circuit with 4mF reserve capacitor and 100mA load: after removing the battery, power remains for 10.8ms.

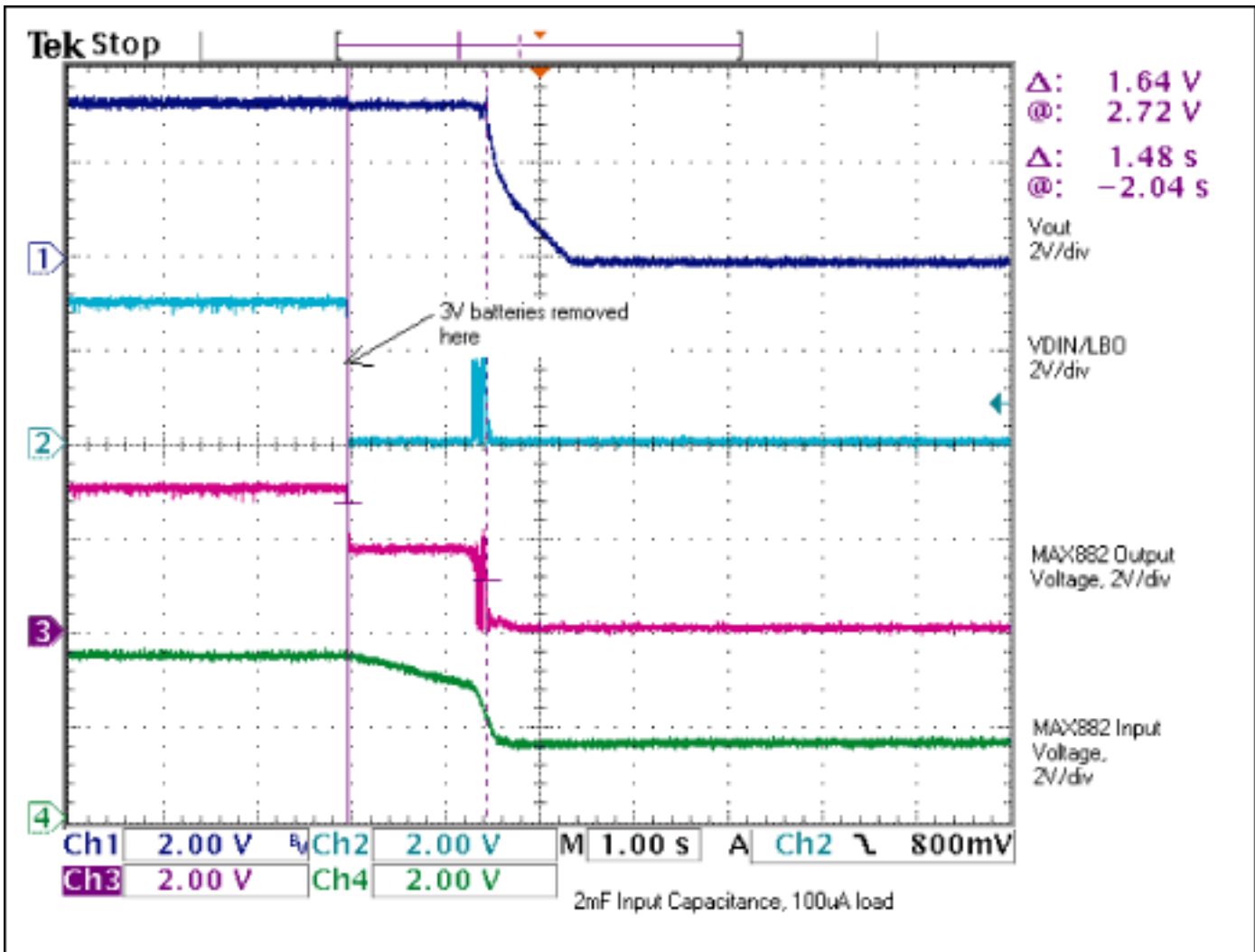

Figure 4. Figure 1 circuit with 2mF reserve capacitor and 100 $\mu$ A load: after removing the battery, power remains for 1.48s.

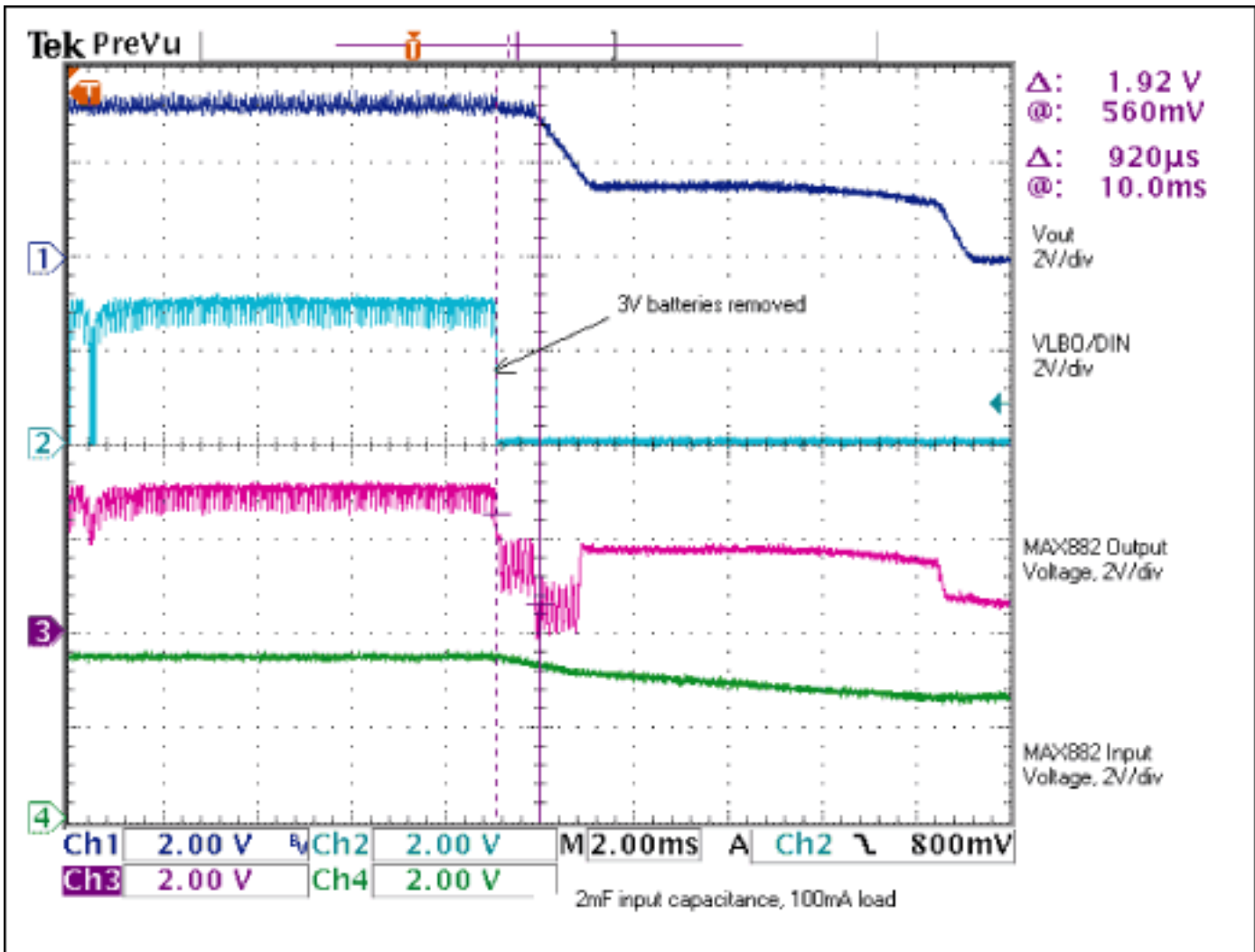

Figure 5. Figure 1 circuit with 2mF reserve capacitor and 100mA load: after removing the battery, power remains for 920µs.

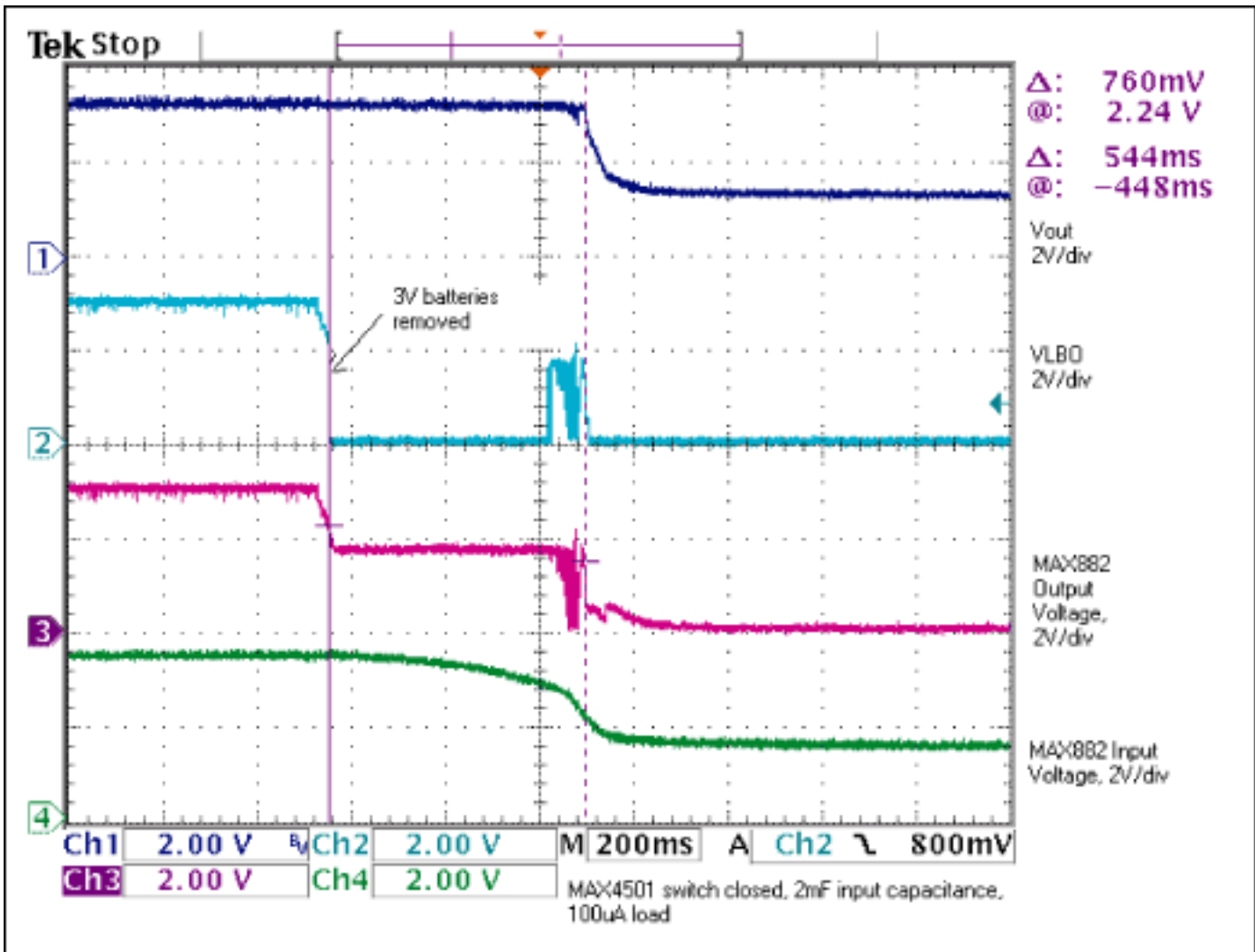

Figure 6. Figure 1 circuit with 2mF reserve capacitor, 100 $\mu$ A load, and switch wired closed: after removing the battery, power remains for 544ms.

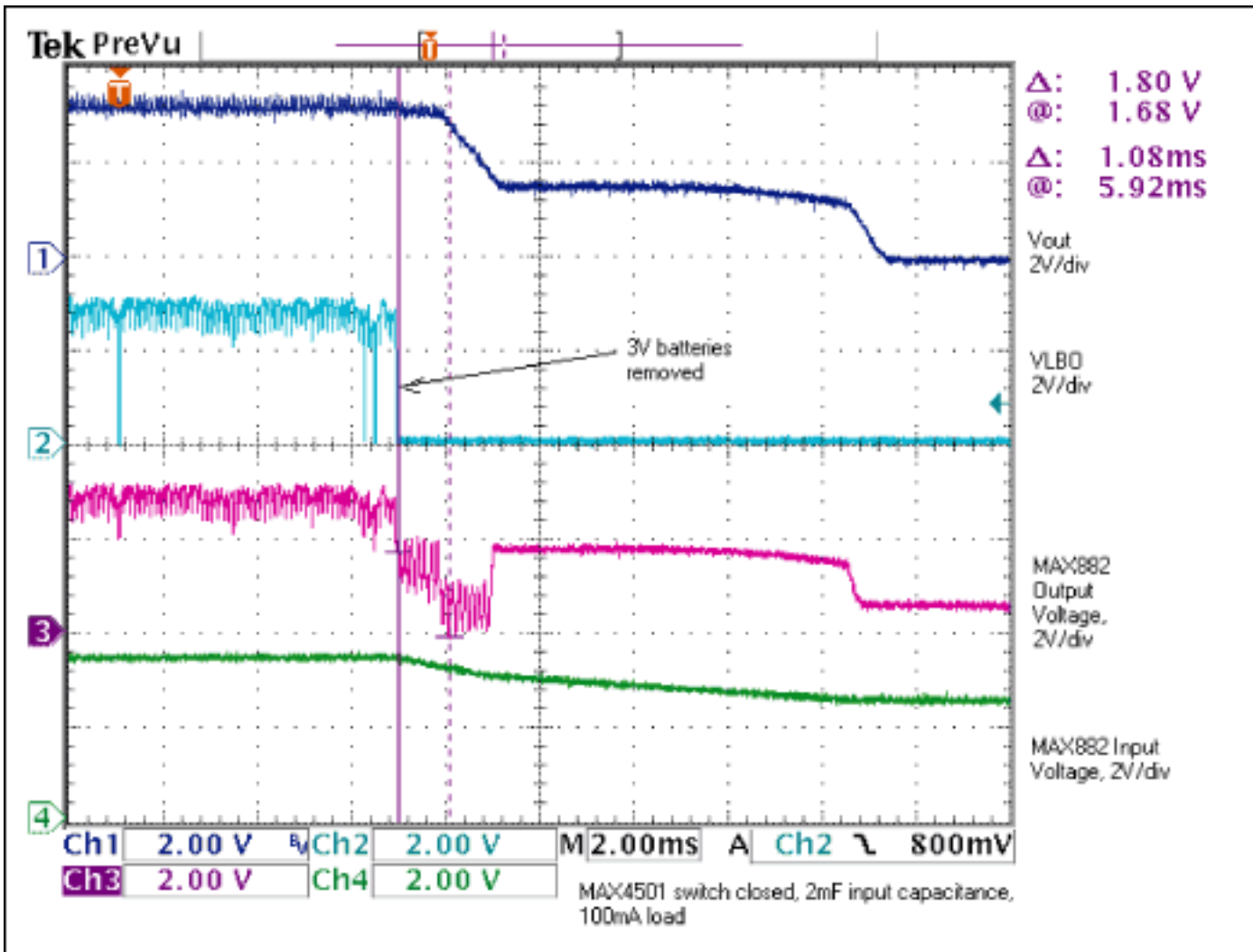

Figure 7. Figure 1 circuit with 2mF reserve capacitor, 100mA load, and switch wired closed: after removing the battery, power remains for 1.08ms.

Application Note 3209: <http://www.maxim-ic.com/an3209>

### More Information

For technical questions and support: <http://www.maxim-ic.com/support>

For samples: <http://www.maxim-ic.com/samples>

Other questions and comments: <http://www.maxim-ic.com/contact>

### Related Parts

MAX1674: [QuickView](#) -- [Full \(PDF\) Data Sheet](#) -- [Free Samples](#)

MAX4501: [QuickView](#) -- [Full \(PDF\) Data Sheet](#) -- [Free Samples](#)

MAX882: [QuickView](#) -- [Full \(PDF\) Data Sheet](#) -- [Free Samples](#)

AN3209, AN 3209, APP3209, Appnote3209, Appnote 3209

Copyright © 2005 by Maxim Integrated Products

Additional legal notices: <http://www.maxim-ic.com/legal>