

APPLICATION NOTE 3180

Standby Current for RS-422 Repeater Is Less Than 3µA

Abstract: The RS-422 interface is an excellent choice for communicating in noisy environments and over a distance. But, when the distance exceeds the RS-422 capability for reliable data transfer, you must add a repeater. The repeater circuit of Figure 1, which must operate from batteries when no power supply is available, draws less than 3µA of current from a 3V supply.

The RS-422 interface is an excellent choice for communicating in noisy environments and over a distance. However, when the distance exceeds the RS-422 capability for reliable data transfer, you must add a repeater. The repeater circuit in **Figure 1**, which must operate from batteries when no power supply is available, draws less than 3µA of current from a 3V supply.

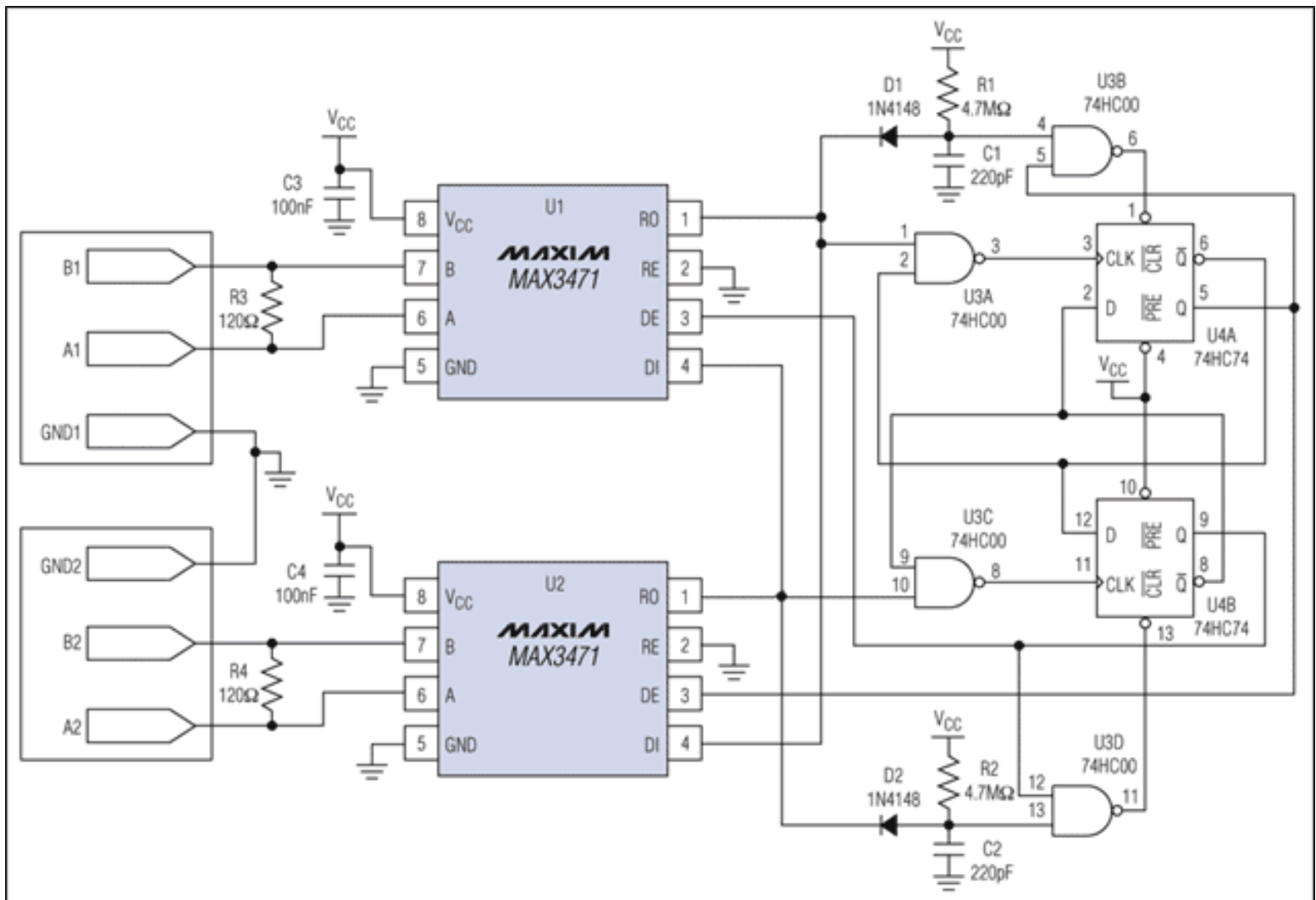

Figure 1. This RS-422 repeater draws only 3µA of standby current.

Low standby power and true fail-safe operation are the key features in this application. U1 and U2 drive their receiver outputs (RO) high when the RS-422 inputs are open circuited or terminated and undriven. An incoming data byte on the differential inputs A1 and B1 forces a transition on RO of U1, and a state machine (right half of the Figure 1 schematic) is latched ON by the falling edge of RO. The state machine asserts a high level at U2's driver-enable pin, causing the incoming data byte to be retransmitted from U2 at full RS-422 levels.

The state machine watches for transitions on RO. When a data-byte transfer is complete (as indicated by no falling edges within a time delay internal to the state machine), the state machine resets itself in anticipation of the next data byte from

either side of the interface.

An incoming data burst (**Figure 2**, top) is retransmitted as outputs A2 (bottom trace) and B2 (middle trace). U2 de-asserts those outputs 700 μ s after the final transition. Other delays can be implemented by adjusting R1/C1 and R2/C2 as shown in Figure 1.

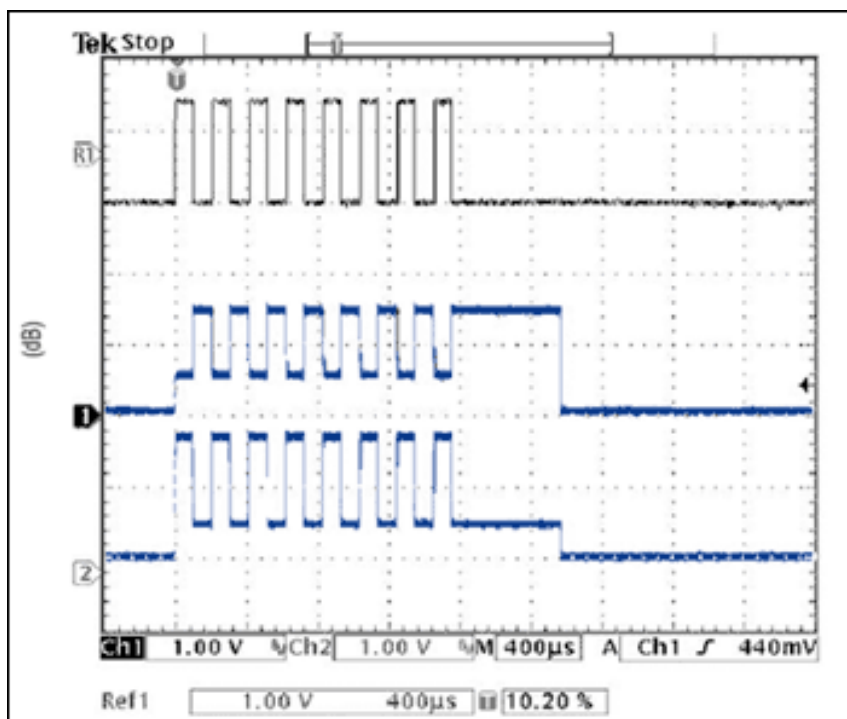

Figure 2. An input data byte causes the repeater to transmit the byte, then go to standby. Vertical scale is 1V per division; horizontal scale is 400 μ s per division.

Application Note 3180: <http://www.maxim-ic.com/an3180>

More Information

For technical questions and support: <http://www.maxim-ic.com/support>

For samples: <http://www.maxim-ic.com/samples>

Other questions and comments: <http://www.maxim-ic.com/contact>

Related Parts

MAX3471: [QuickView](#) -- [Full \(PDF\) Data Sheet](#) -- [Free Samples](#)

AN3180, AN 3180, APP3180, Appnote3180, Appnote 3180

Copyright © by Maxim Integrated Products

Additional legal notices: <http://www.maxim-ic.com/legal>