

APPLICATION NOTE 3175

Base-Station RF Power-Amplifier Biasing

Power amplifiers used in base stations require biasing for proper RF performance. This article explains the two classes of biasing that are prevalent in the RF industry, analyzes their characteristics, and shows implementations with existing ICs.

The power device of choice for base-station amplifiers today is the lateral DMOS (LDMOS) MOSFET. This article uses it to illustrate biasing techniques.

RF Classes and Biasing

LDMOS amplifiers used in RF circuits exhibit varying degrees of nonlinearity, depending on the DC-bias level upon which the input RF wavelshape rides. That is, while maintaining a constant RF gating signal, the output current's (I_{out}) harmonic content varies as the DC bias at the gate of an LDMOS device (**Figure 1**) changes. The harmonic content of the LDMOS amplifier's current is important because, in the RF load, it creates power interference with the local bandwidth (in-band interference) or with adjacent bandwidths (out-of-band interference).

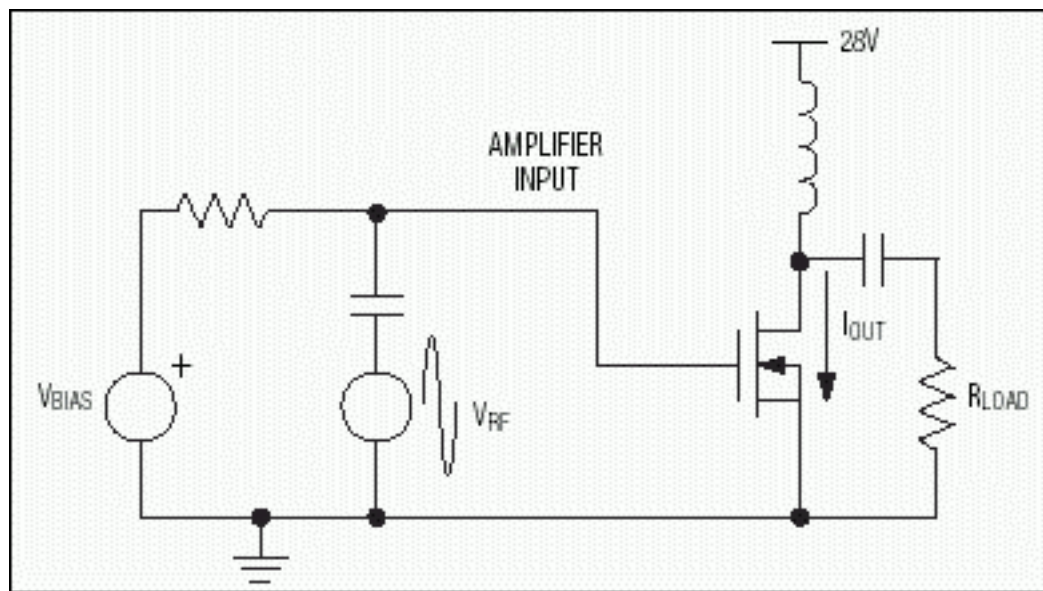

Figure 1. LDMOS device gating is shown with an uncontrolled DC bias.

The best linearity occurs when the output current tracks the input voltage—a 360° conduction angle. Operating the MOSFET in this manner (i.e., class-A operation) creates less distortion than when biasing it in any other way. From a power-dissipation perspective, however, class-A operation is least desirable because it consumes the most DC current.

At high RF power, given a nominal power-supply voltage of 28V, the DC power dissipated in the amplifier is prohibitive. For this reason, RF engineers use class-AB biasing in the last stage of an amplifier chain, while they favor class-A operation in the preceding stages where power dissipation is smaller by orders of magnitude. In class-AB stages, the output current does not track the input voltage entirely, and thus the amplifier's conduction

angle is lower than 360°.

Distortion of the RF signal in class AB is more significant than in class A. The spectrum of this distortion is wider and more densely populated than that of class A. However class-AB power dissipation is lower because the average current into the amplifier is lower. In short, the basis for choosing a given class of commercial RF amplifiers is a tradeoff between linearity and efficiency.

Biasing Requirements and LDMOS Behavior

Biasing requires managing the DC content in the LDMOS current across temperature and supply variation. The ultimate objective is to ensure that the amplifier RF gain, as well as its distortion levels, varies within limits consistent with requirements. In this respect, proper biasing can assist linearization techniques to minimize distortion. The equation governing LDMOS's gain is $I_{out} = K (V_{gs} - V_{th})^2$, where K is a constant reflecting gain due to electron mobility and V_{th} is the FET's threshold. Both K and V_{th} are temperature dependent. In **Figure 2**, LDMOS characteristics are shown across temperature. In class AB, designers tend to operate the bias to the left of the crossover region where the gain has a positive temperature coefficient. In class A, operation occurs to the right of the crossover region.

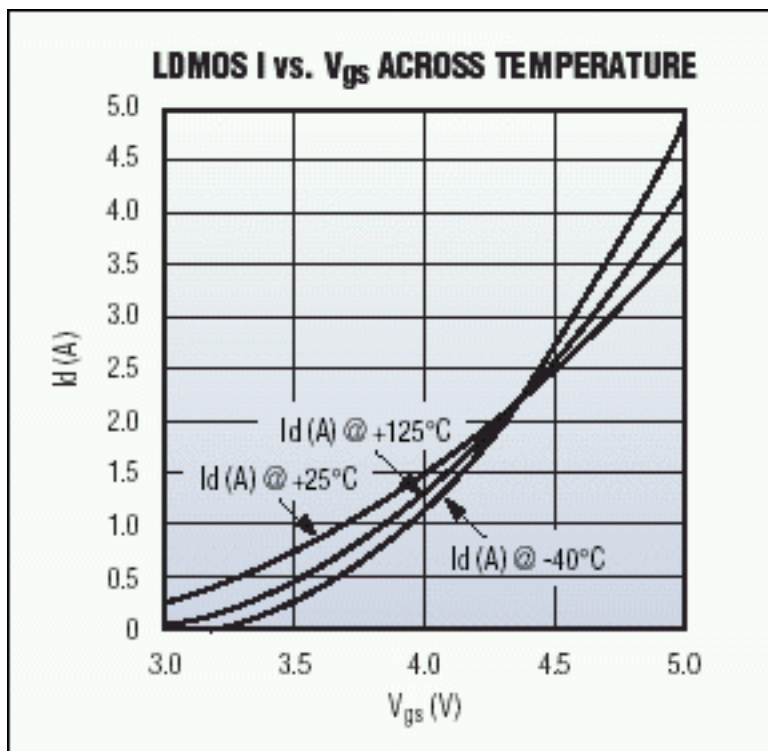

Figure 2. LDMOS characteristics are shown across temperature.

Controlling Class-A and Class-AB Bias with the DS1847

Figure 3 shows a DS1847 dual, temperature-controlled variable resistor controlling the gate of an LDMOS amplifier. The DS1847's internal temperature sensor provides a temperature reading to its look-up tables. These look-up tables adjust the IC's two 256-position variable resistors so the amplifier's gate receives the proper bias voltage. The user programs the look-up tables to generate a constant LDMOS-amplifier output current. Refer to Figure 2 (or to manufacturer-specific data curves) for LDMOS characteristics. By using the two resistors to attenuate the reference voltage, a temperature-insensitive voltage is maintained.

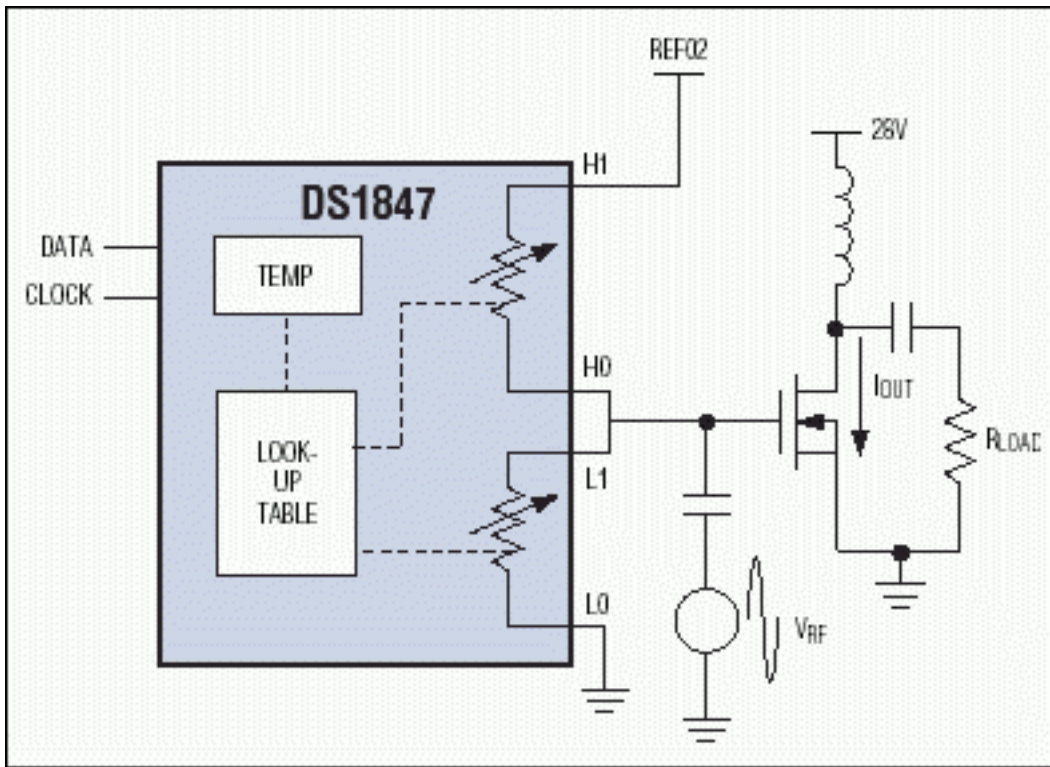

Figure 3. DS1847 dual, temperature-controlled variable resistor controls the gate of an LDMOS amplifier.

A similar article appeared in the November 2003 issue of *Wireless Design & Development*.

Application Note 3175: <http://www.maxim-ic.com/an3175>

More Information

For technical questions and support: <http://www.maxim-ic.com/support>

For samples: <http://www.maxim-ic.com/samples>

Other questions and comments: <http://www.maxim-ic.com/contact>

Related Parts

DS1847: [QuickView](#) -- [Full \(PDF\) Data Sheet](#) -- [Free Samples](#)

DS1848: [QuickView](#) -- [Full \(PDF\) Data Sheet](#) -- [Free Samples](#)

AN3175, AN 3175, APP3175, Appnote3175, Appnote 3175

Copyright © 2005 by Maxim Integrated Products

Additional legal notices: <http://www.maxim-ic.com/legal>