



[Maxim](#) > [App Notes](#) > [TELECOM](#)

Keywords: ultramapper, ultraframer, transmux, clear channel, map/demap, T3, E3, line interface units, t3 e3, Mar 15, 2004
LIUs, trans mux

APPLICATION NOTE 3131

Connecting the Agere Ultramapper Device Family to Dallas T3/E3 LIUs

Abstract: This application note shows how to connect our T3/E3 line interface units (LIUs) in clear-channel, transMUX, and map/demap applications with the Agere Ultramappers™.

Introduction

This application note shows a how to connect the Dallas DS3150 or DS315x series of T3/E3 LIUs to the Agere Ultramappers™. The DS3150 and DS315x series of T3/E3 LIUs perform all the functions necessary for interfacing at the physical layer to T3 and E3 lines. The DS3150 is a Hardware only, single port T3/E3 LIU, while the DS3151, DS3152, DS3153 and DS3154 offer both Hardware and CPU Bus modes in 1, 2, 3, or 4 ports respectively. This application note will illustrate connecting to the DS3150 with the connection to the DS315x series being similar.

The Agere Ultramapper Device Family includes the following: Ultramapper, UltramapperLite, Ultramapper Full Transport, and Ultraframer. This application note will discuss applications that pertain only to the following Agere devices: UltramapperLite and Ultraframer

The following diagrams will illustrate Dallas T3/E3 LIUs from the DS315x series or multiples of the DS3150. Depending on the linecard/system design, the designer will need to choose which of the five Dallas LIUs to utilize.

Applications

T3/E3 Clear Channel Application

In this application, two UltramapperLites are configured to terminate/transmit twelve T3/E3 signals from/to T3/E3 mapped STS-12/STM-4 signals.

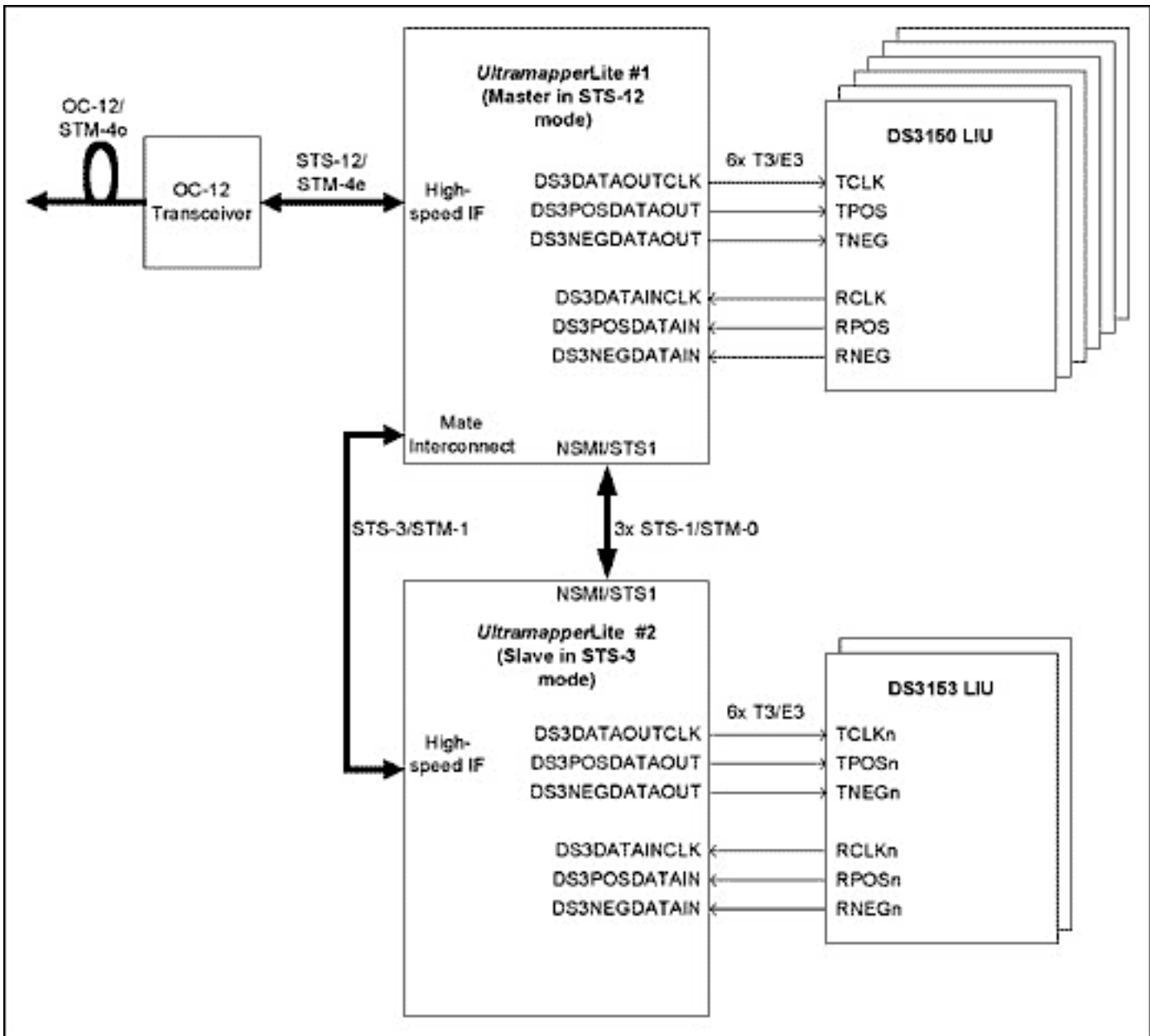

Figure 1. T3/E3 clear channel application.

T3/E3 TransMUX Application

In this application, four UltramapperLites are configured to transMUX between two different scenarios: between one VT1.5/VC11 mapped STS-12 and twelve T1 channelized T3 signals; and between one VT2/VC12 mapped STS-12 and twelve E1 channelized E3 signals.

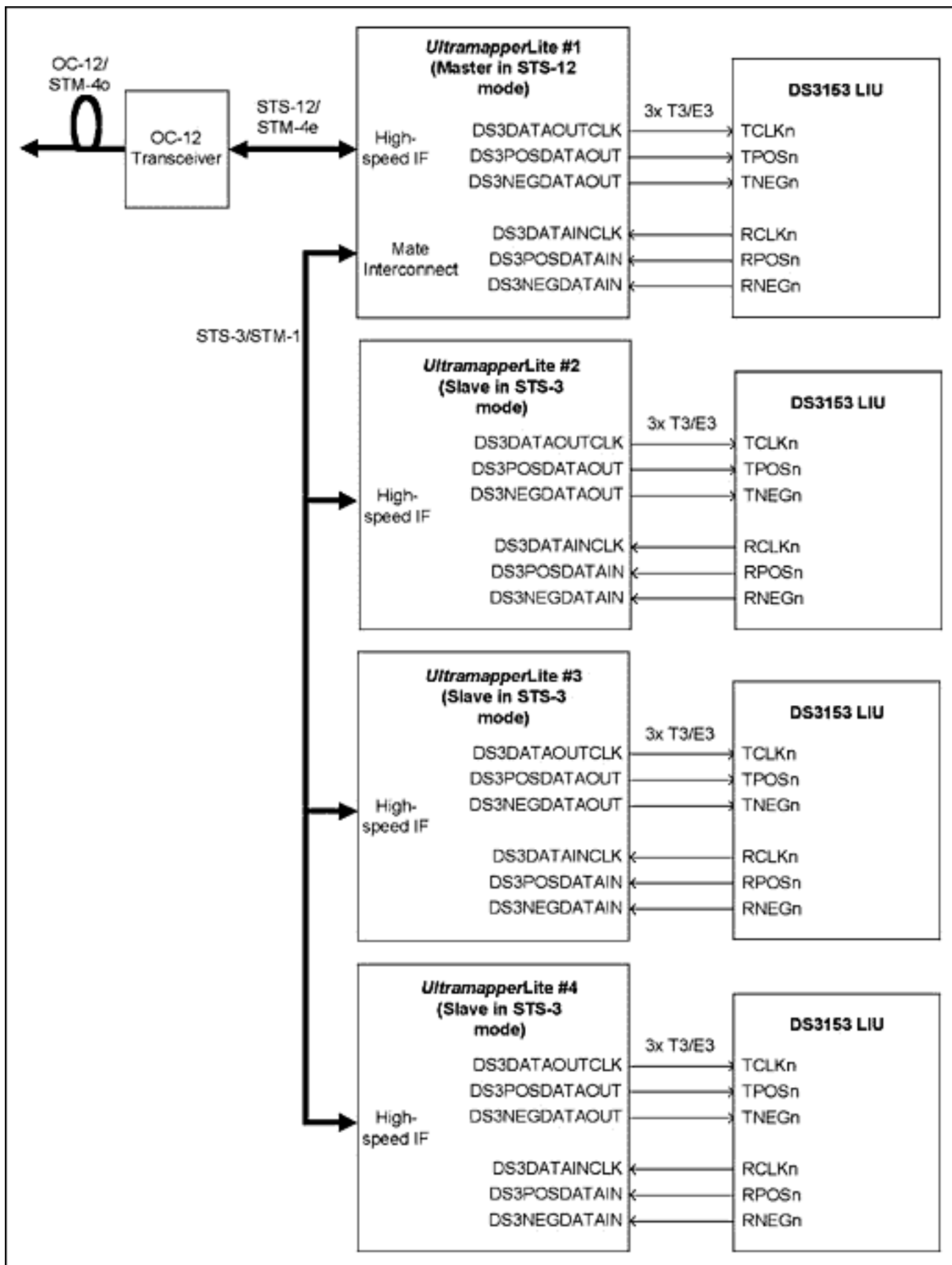

Figure 2. T3/E3 TransMUX application.

T3/E3 and T1/E1 Map/Demap Application

In this application, one Ultraframer is configured to map/demap between three channelized T3/E3 signals and 84/48 T1/E1 signals.

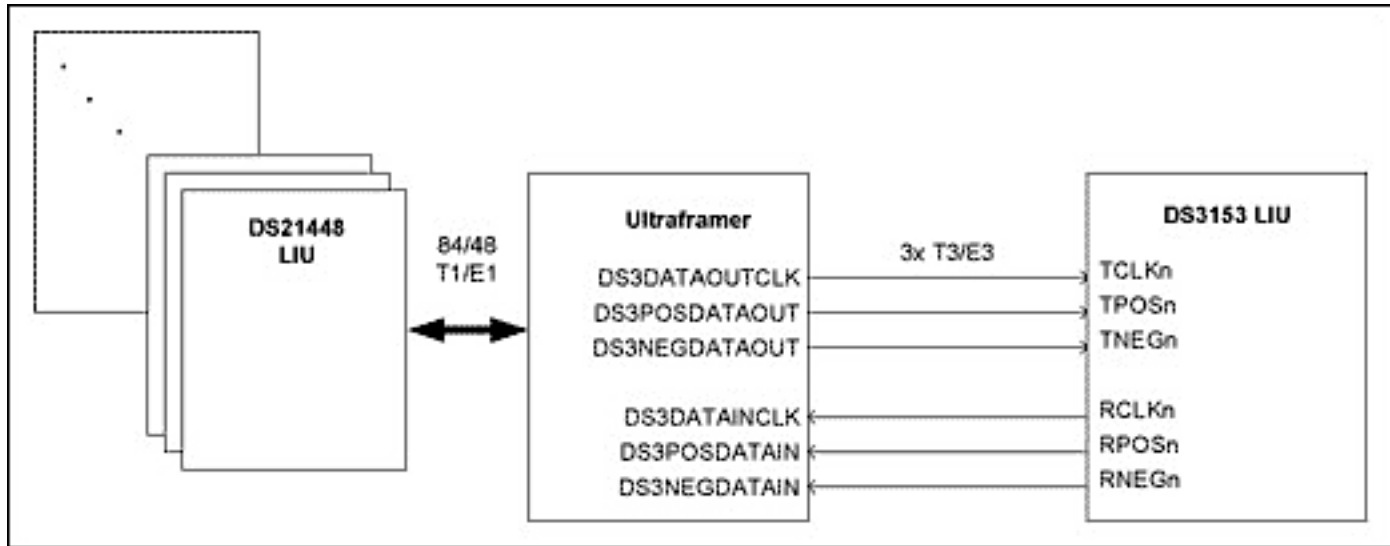

Figure 3. T3/E3 and T1/E1 Map/Demap application.

T3/E3 and DS0/E0 Map/Demap Application

In this application, one Ultraframer is configured to map/demap between three channelized T3/E3 signals and upto 2016/1536 timeslots of DS0/E0 signals.

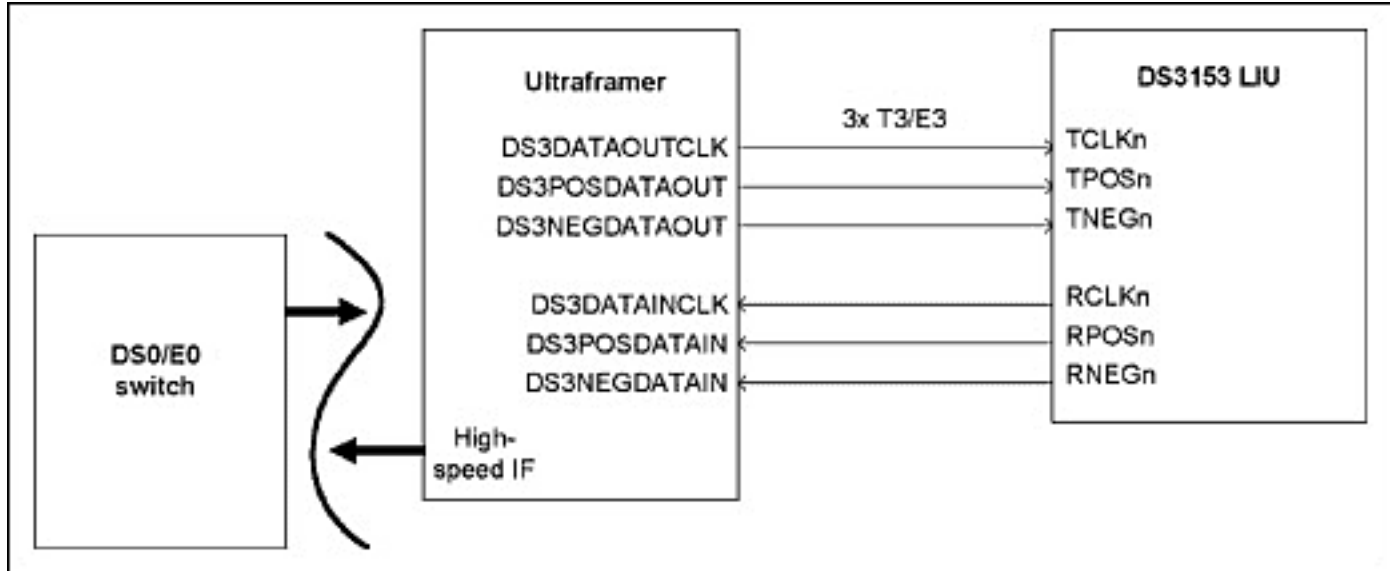

Figure 4. T3/E3 and DS0/E0 Map/Demap application.

Dallas T3/E3 Line Interface Unit Configuration

With the Agere Ultramapper in M13/E13 MUX/DeMUX applications, a free-running 44.736 MHz T3 or 34.368 MHz E3 clock should be provided to pin DS3DATAOUTCLK for M13/E13 functionality. In SONET/SDH to T3/E3 applications where DS3/E3 Digital Jitter Attenuator is used on the receive path: SONET/SDH \Leftrightarrow TMUX/STS-1LT \Leftrightarrow SPE \Leftrightarrow (DS3/E3 Digital Jitter Attenuator) \Leftrightarrow T3/E3; the DS3DATAOUT input is not needed for M13/E13 functionality. Instead, a free-running 44.736 MHz DS3XCLK clock and a 34.368 MHz E3XCLK clock are required for T3/E3 Digital Jitter Attenuator functionality. The Agere Ultramapper T3/E3 line interface is straightforward to

connect to the Dallas T3/E3 LIUs. As far as T3/E3 connections are concerned, there are no differences between the master Ultramapper and slave Ultramapper.

The interface between a T3/E3 analog line and a Line Interface Unit can be in either bipolar or unipolar mode. Table 1 lists the register settings of the Agere Ultramapper for DS3/E3 Bipolar/Unipolar control.

Table 1. Agere Ultramapper™ DS3/E3 Bipolar/Unipolar Control Bits

Block Name	Register Name	Address	Description
SPEMPR	SPEMPR_TDS3_BIPOLAR	0x19 [1]	Transmit DS3/E3 Bipolar/Unipolar. Note this is valid only if register 0x0018 [13:12] = 11.
SPEMPR	SPEMPR_RDS3_BIPOLAR	0x19 [0]	Receive DS3/E3 Bipolar/Unipolar. Note this is valid only if register 0x0018 [5:4] = 11.
DS3DJA	DS3DJA_DS3_BIPOLAR	0x15 [5:0]	Per Channel Control Bit 1: HBD3 or B3ZS. 0: Unipolar.
DS3DJA	DS3DJA_DS3_B3ZS	0x14 [5:0]	Per Channel Control Bit 1: B3ZS coding. 0: HDB3 coding.
M13	M13_BIPOLAR	0x5D [0]	1: B3ZS encoding/decoding, i.e., DS3 I/O is in dual-rail mode where each rail carries a polarity of a bipolar I/O. 0: DS3 I/O is a single-rail, unencoded NRZ signal.
E13	E13_TE3_BIPOLAR	0x23 [2]	1: E3 output is HDB3 encoded and dual-rail. 0: E3 output is single-rail unencoded.
E13	E13_RE3_IN_CTL	0x26 [5:4]	00: HDB3 decode disabled (input data on positive rail only). 01: HDB3 decoder enabled, input on P/N rails. 10: HDB3 decoder disabled (input data on positive rail only). 11: HDB3 decoder disabled, negative input rail carries HDB3 error count from external LIU.

Conclusion

This application note has shown how to connect our T3/E3 LIUs to the Agere Ultramapper Device Family.

If you have further questions about connecting any of our T3/E3 LIUs, then please contact the Telecommunication Applications support team via email telecom.support@dalsemi.com or call 972-371-6555.

Dallas DS3/E3 LIU Information

For more information about our T3/E3 LIUs, please consult the data sheets available on our website at www.maxim-ic.com/telecom.

Application Note 3131: <http://www.maxim-ic.com/an3131>

More Information

For technical questions and support: <http://www.maxim-ic.com/support>

For samples: <http://www.maxim-ic.com/samples>

Other questions and comments: <http://www.maxim-ic.com/contact>

Related Parts

DS3150: [QuickView](#) -- [Full \(PDF\) Data Sheet](#) -- [Free Samples](#)

DS3151: [QuickView](#) -- [Full \(PDF\) Data Sheet](#) -- [Free Samples](#)

DS3152: [QuickView](#) -- [Full \(PDF\) Data Sheet](#) -- [Free Samples](#)

DS3153: [QuickView](#) -- [Full \(PDF\) Data Sheet](#) -- [Free Samples](#)

DS3154: [QuickView](#) -- [Full \(PDF\) Data Sheet](#) -- [Free Samples](#)

AN3131, AN 3131, APP3131, Appnote3131, Appnote 3131

Copyright © by Maxim Integrated Products

Additional legal notices: <http://www.maxim-ic.com/legal>