



## APPLICATION NOTE 3080

# Accurate Power Control of the MAX3740 Laser Driver

*Abstract: Three circuit approaches for the accurate control of the laser power of the MAX3740 Laser Driver are described and analyzed. Circuit schematics and simulation results are presented along with the advantages and disadvantages of each approach.*

The operating power level of the MAX3740 VCSEL Laser Driver can be set via software control. This can be accomplished with the DS1859 digital potentiometer but it is trickier than it may seem. This article will identify the challenges, show two different ways the DS1859 and a discrete resistor can be configured to control operating power (Solution #1 and Solution #2), and present a new circuit with an op amp that addresses all the shortcomings of the discrete solutions (Solution #3). Simulation results are shown for the relationship between photodiode current and potentiometer voltage for each of the options. Finally, the advantages and disadvantages of each option are summarized.

The best circuit for a particular application will depend on the designer's requirements. Things that need to be considered include the photodiode current to achieve the desired laser power level, adjustment range, and the required resolution. With the information in this article the designer will be able to determine the best option for a particular application.

## Challenges

The MAX3740 data sheet specifies the use of a resistor between the reference pin (REF) and the power monitor photodiode (MD) to set the photodiode current. The power control loop drives the laser diode to an intensity that yields this photodiode current, and therefore the average operating power level. The problem is the nominal voltage at MD is 1.6V and the nominal voltage at REF is 1.8V. This only gives 0.2V across the resistor to set the photodiode current. Digital potentiometers like those in the DS1859 can have minimum resistances up to 1K. This would give a maximum current of only 200 $\mu$ A. You can increase this current level with a fixed resistor but you can't change the limited adjustment range, nonlinearity and poor resolution at high currents.

Another challenge with using the DS1859 is the wide variation of voltages at MD and REF on the MAX3740. The delta between these two points is very stable at 0.2V but the common mode can change up and down by  $\pm 0.5$ V. This large variation of MD relative to ground means the current defined by a resistor between this node and ground will have the same large variation.

## Solution #1

In this solution the DS1859 variable resistor and the 806 $\Omega$  fixed resistor are placed between REF and MD, please refer to **Figure 1**. The fixed resistor carries  $0.2\text{V}/806 = 248\mu\text{A}$ . The variable resistor carries  $0.2\text{V}/50\text{K}$  (DS1859 max value) = 4 $\mu$ A to  $0.2\text{V}/1\text{K}$  (DS1859 min value) = 200 $\mu$ A. The sum of the currents through the fixed and variable resistors determine total current through the photodiode. This technique gives a nonlinear response with good resolution at low currents. It is not affected by voltage variations at MD.

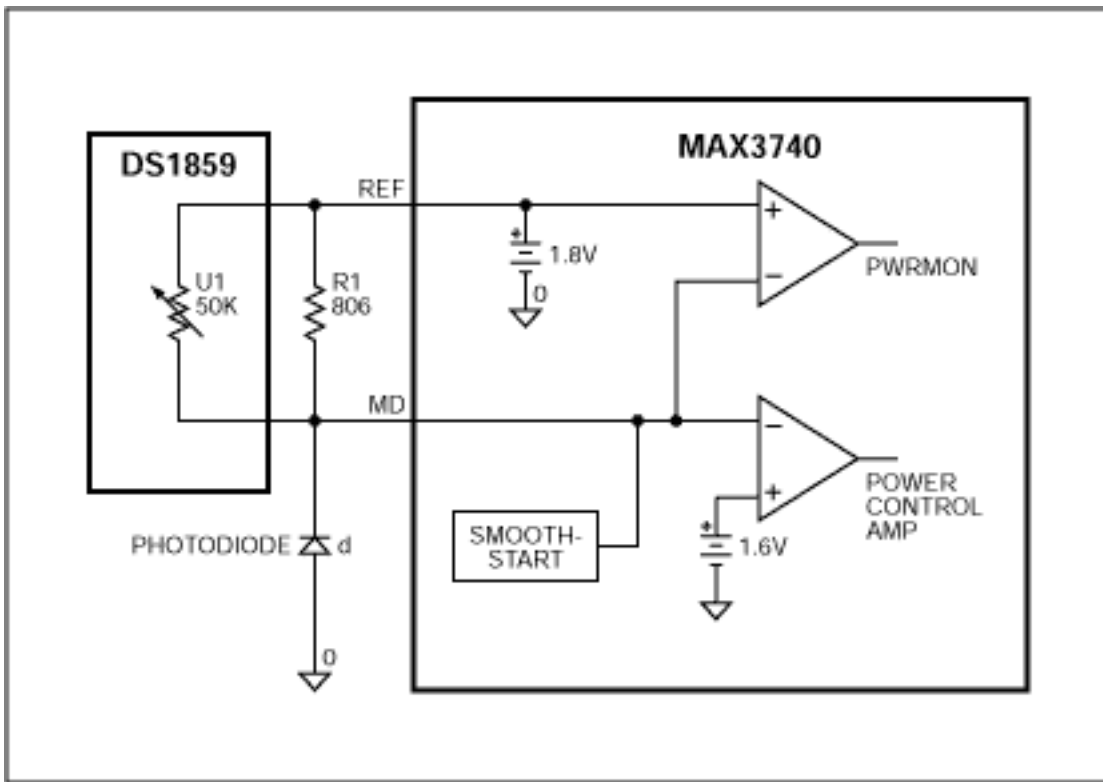

Figure 1. Solution #1 schematic.

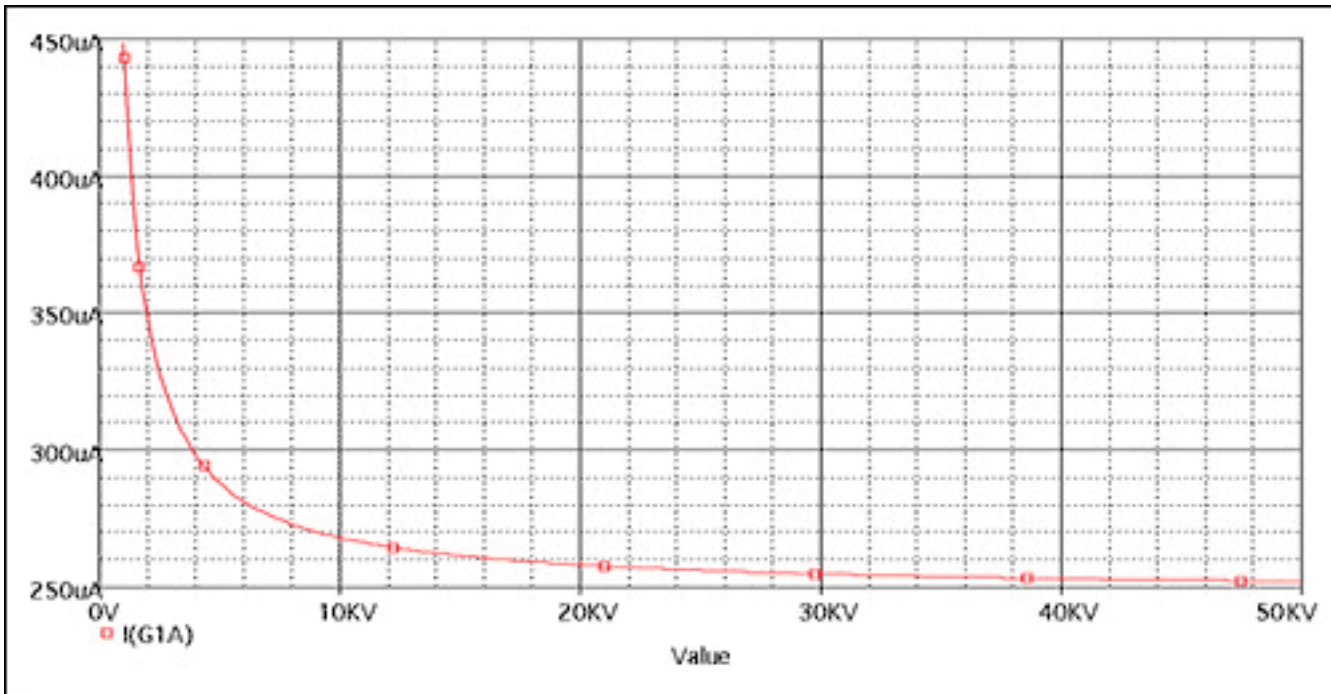

Figure 2. Solution #1 simulation results (X axis DS1859 resistance in  $\Omega$ ).

Option 1 Summary		
DS1859 Value	Photodiode Current MD = 1V	Photodiode Current MD = 2.0V
1K	448uA	448uA
1.96K	350uA	350uA
50K	252uA	252uA
Response: Nonlinear, 1/R inverse function, negative slope		
Advantages: Insensitive to DS1859 MD voltage variations, minimum par		
Disadvantages: Nonlinear response, poor resolution at high currents, limited current adjustment range		

Figure 3. Solution #1 summary.

## Solution #2

In this solution the DS1859 variable resistor is put between MD and ground, and a 243Ω fixed resistor is put between REF and MD, please refer to **Figure 4**. The current in the fixed resistor is  $0.2V/243 = 823\mu A$ . The current in the variable resistor is  $1.6V$  (MD nominal)/ $50K$  (DS1859 max) =  $32\mu A$  to  $1.6V$  (MD nominal)/ $1K$  (DS1859 min) =  $1600\mu A$ . The total current through the photodiode is the current through the fixed resistor minus the current through the variable resistor. This technique gives good resolution at high currents. The current values are strongly dependent on voltage variations at MD. Note that the photodiode current can go negative for low values of resistance. **Figure 5** shows the photodiode variation with MD and REF varied through a  $\pm 5V$  range.

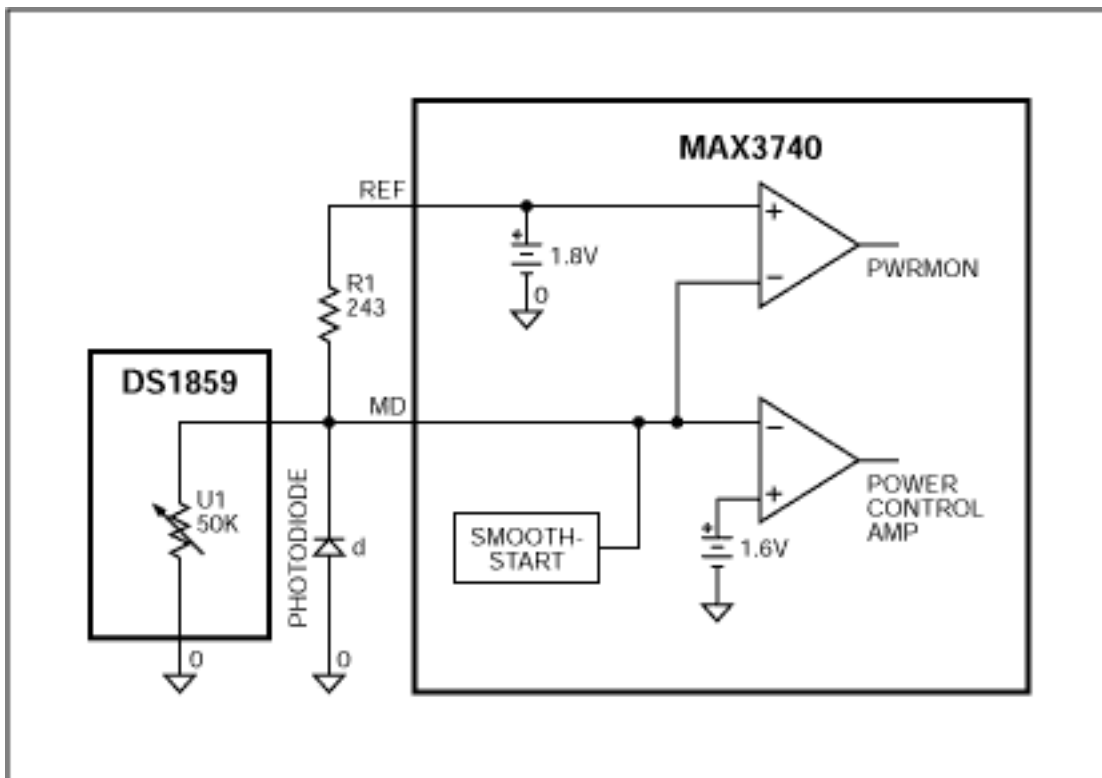

Figure 4. Solution #2 schematic.



$$\begin{aligned}
 V_O &= MD + (MD - REF) * DS1859/R3 \\
 V_O &= MD - 0.2V * DS1859/R3 \\
 V_O &= 1.0V \text{ (min)} - 0.2V * 1K \text{ (DS1859 min)}/10K = 0.98V \\
 V_O &= 1.0V \text{ (min)} - 0.2V * 50K \text{ (DS1859 max)}/10K = 0V \\
 V_O &= 2.0V \text{ (max)} - 0.2V * 1K \text{ (DS1859 min)}/10K = 1.98V \\
 V_O &= 2.0V \text{ (max)} - 0.2V * 50K \text{ (DS1859 max)}/10K = 1.0V
 \end{aligned}$$

The current through R2 is derived and calculated as follows:

$$\begin{aligned}
 I(R2) &= (V_O - MD)/R2 \\
 I(R2) &= V_O/R2 - MD/R2 \\
 I(R2) &= (MD - 0.2V * DS1859/R3)/R2 - MD/R2 \\
 I(R2) &= MD/R2 - 0.2V * DS1859/R2 * R3 - MD/R2 \\
 I(R2) &= -0.2V * DS1859/R2 * R3 \\
 I(R2) &= -DS1859/62,000,000 \\
 I(R2) &= -1K \text{ (DS1859 min)}/62,000,000 = -16\mu A \\
 I(R2) &= -50K \text{ (DS1859 max)}/62,000,000 = -806\mu A
 \end{aligned}$$

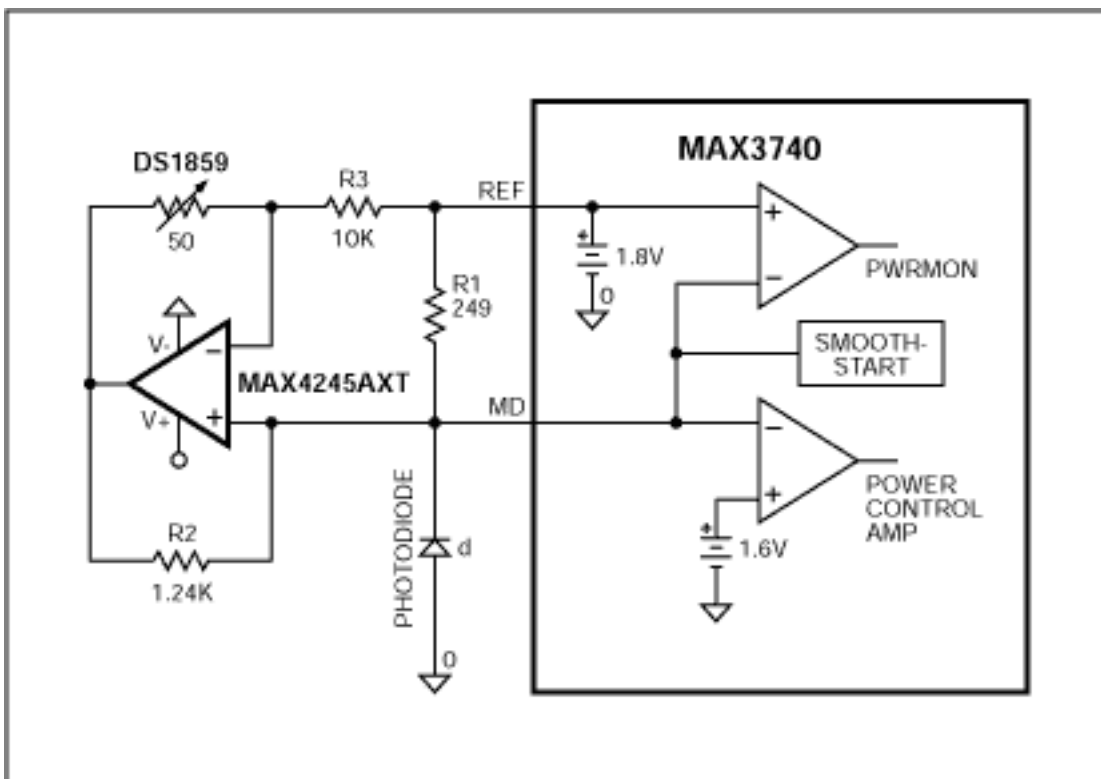

Figure 7. Solution #3 Schematic (X axis DS1859 resistance in  $\Omega$ ).

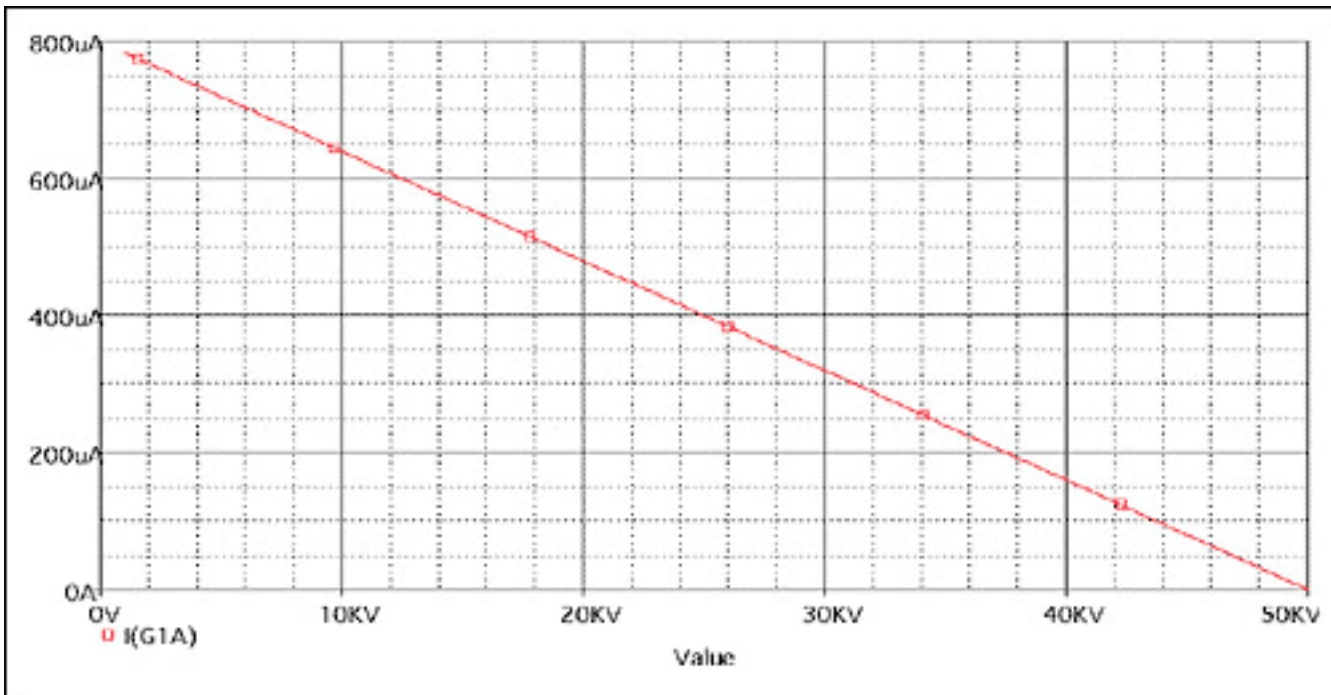

Figure 8. Solution #3 simulation results.

Option 3		
DS1859 Value	Photodiode Current MD = 1V	Photodiode Current MD = 2.0V
1K	784uA	784uA
28.11K	350uA	350uA
50K	0uA	0uA
<b>Response</b>	Linear, negative slope	
<b>Advantages</b>	Linear response, can be scaled for any current range desired insensitive to DS1859 MD voltage variations	
<b>Disadvantages</b>	Requires additional OpAmp and 2 resistors	

Figure 9. Solution #3 summary.

## Summary

Three solutions were presented to control the power level of the MAX3740 Laser Driver. Solution #1 and #2 are very simple, trading off performance for simplicity. Solution #3, by adding an op amp, results in very good linear control that is insensitive to component variations. Each designer can chose the optimum solution for their needs.

Application Note 3080: <http://www.maxim-ic.com/an3080>

### More Information

For technical questions and support: <http://www.maxim-ic.com/support>

For samples: <http://www.maxim-ic.com/samples>

Other questions and comments: <http://www.maxim-ic.com/contact>

### Related Parts

DS1859: [QuickView](#) -- [Full \(PDF\) Data Sheet](#) -- [Free Samples](#)

AN3080, AN 3080, APP3080, Appnote3080, Appnote 3080

Copyright © by Maxim Integrated Products

Additional legal notices: <http://www.maxim-ic.com/legal>