

APPLICATION NOTE 3042

# LNA for MMDS Band (2.65GHz) Features Gain Step

*Abstract: The MAX2645 is a Silicon Germanium (SiGe) Low-Noise Amplifier (LNA) that features a 25dB gain step, shutdown mode, and adjustable IP3. The LNA has been optimized for wireless broadband applications in the MMDS, 2.65GHz frequency range. The MAX2645 features +17.5dB of gain, noise figure of 2.0dB, and an IIP3 of +3.7dBm in the high gain mode. In low gain mode, the MAX2645 provides 7.9dB of insertion loss and an IIP3 of +15.8dBm. With a typical operating supply voltage of +3.3V, the supply current is a low 8.9mA in the high gain mode, 2.7mA in the low gain mode, and typically 0.1µA in the shutdown mode.*

Table 1 summarizes the performance of the MAX2645 operating at 2.65GHz. The schematic used to optimize the MAX2645 for 2.65GHz is represented in **Figure 1**. Table 2 is the component list. **Figures 2** through **6** demonstrate the performance of the LNA in both high gain and low gain modes over the frequency band of 2.6GHz to 2.7GHz. Tuning capacitors are common Murata 0402 GRP1555C (GRM36) series, and the tuning inductors are Murata 0402 printed LQP10A series. For further information, consult the MAX2645 SiGe LNA datasheet and EV kit datasheet.

**Table 1. MAX2645 SiGe LNA Performance at 2.65GHz**

Mode	I <sub>CC</sub> (mA)	Gain (dB)	NF (dB)	IIP3 (dBm)	S11 (dB)	S22 (dB)
High Gain	8.9	+17.5	2.0	+3.7	10.5	19.4
Low Gain	2.7	-7.9	14.2	+15.8	8.4	8.2

Note: V<sub>CC</sub> = +3.3V, R<sub>BIAS</sub> = 20kΩ

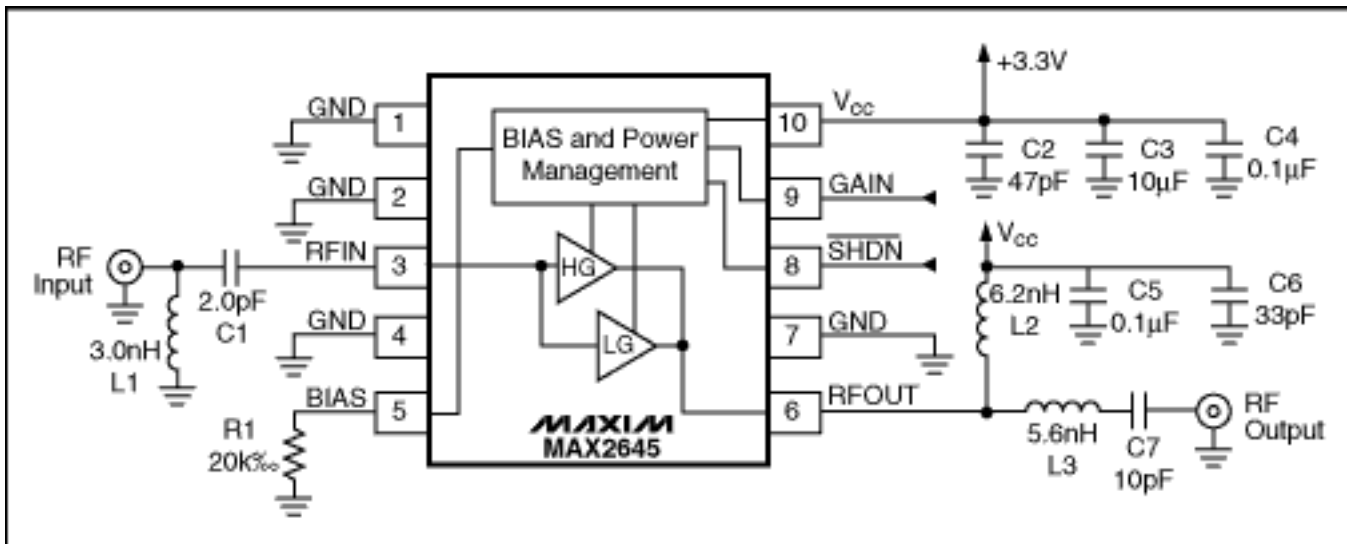

Figure 1. MAX2645 SiGe LNA performance at 2.65GHz.

**Table 2. Component List**

Designation	Quantity	Description
C1	1	2.0pF $\pm$ 5% ceramic capacitor (0402) Murata GRM36COG020C50
C2	1	47pF $\pm$ 5% ceramic capacitor (0402) Murata GRM36COG470J50
C3	1	10 $\mu$ F, 16V tantalum capacitor AVX TAJC106K016
C4, C5	2	0.1 $\mu$ F $\pm$ 10% ceramic capacitors (0603) Murata GRM39X7R104K016
C6	1	33pF $\pm$ 5% ceramic capacitor (0402) Murata GRM36COG330J50
C7	1	10pF $\pm$ 5% ceramic capacitor (0402) Murata GRM36COG100D50
L1	1	3nH $\pm$ 5% inductor (0402) Murata LQG15HN3N0S02
L2	1	6.8nH $\pm$ 5% inductor (0402) Murata LQG15HN6N8J02
L3	1	5.6nH $\pm$ 5% inductor (0402) Murata LQG15HN5N6S02
R1	1	20k $\Omega$ $\pm$ 1% resistor (0603)

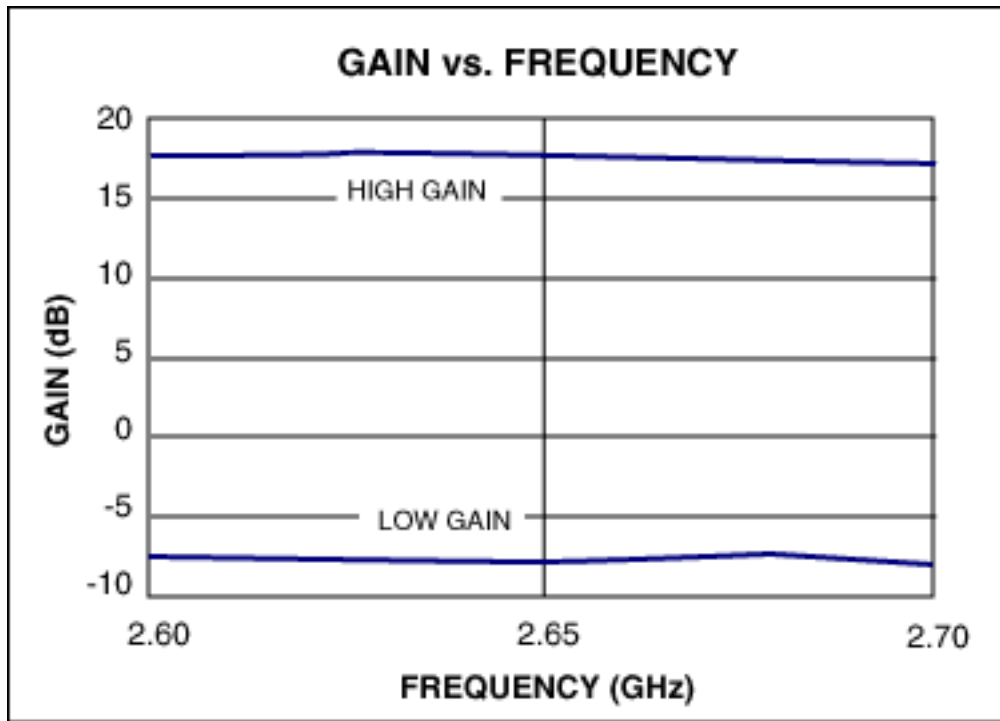

Figure 2. MAX2645 gain vs. frequency plot.

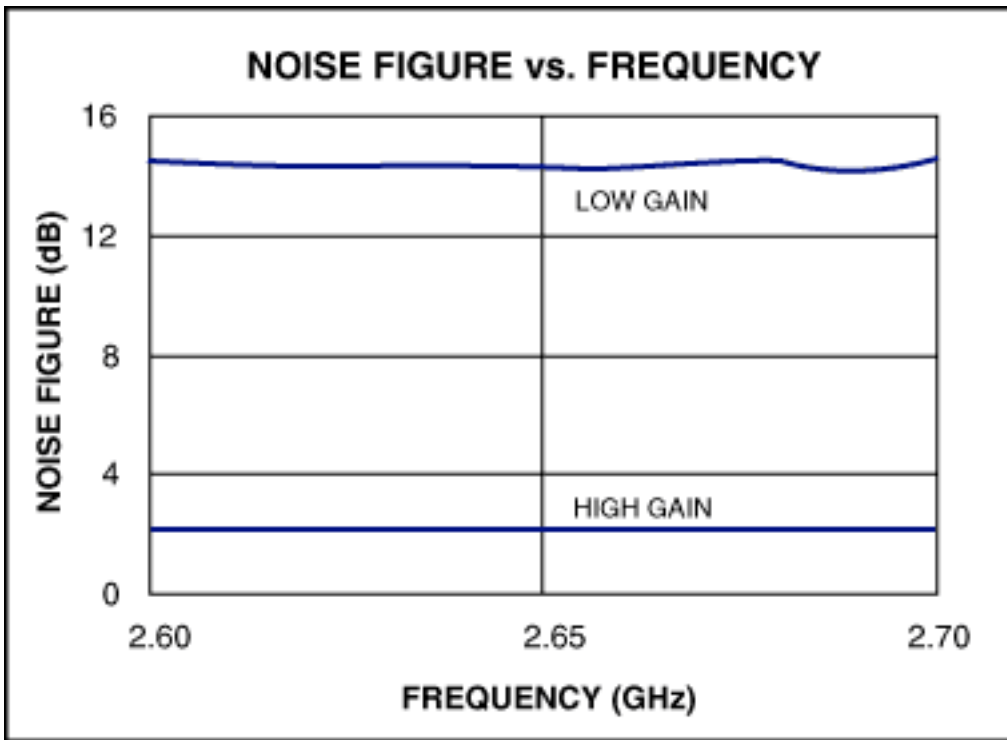

Figure 3. MAX2645 noise figure vs. frequency plot.

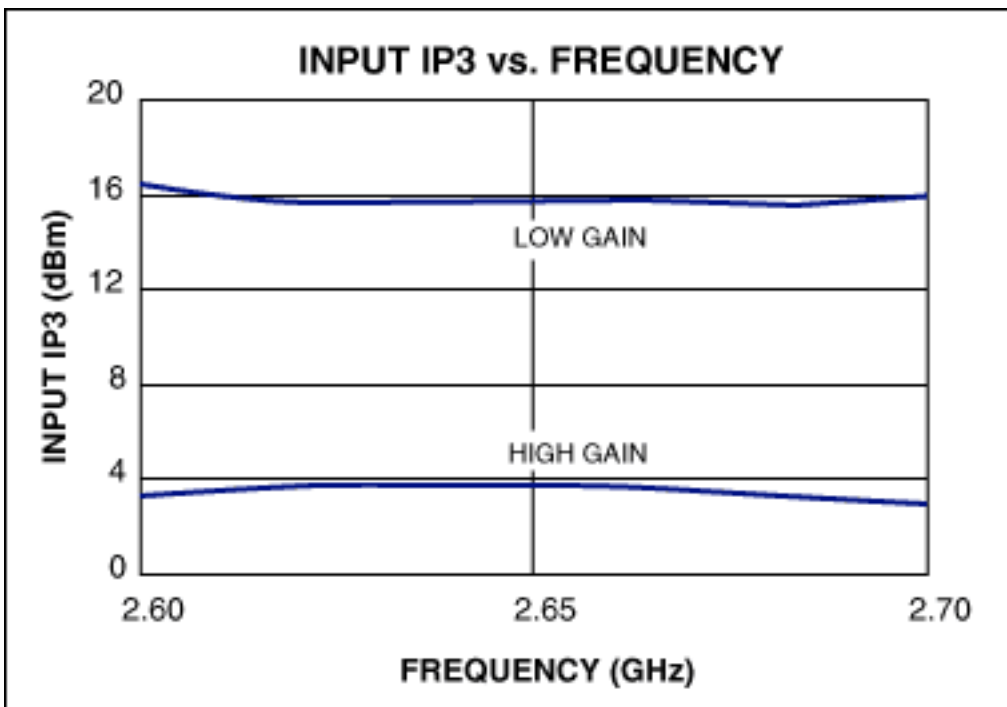

Figure 4. MAX2645 input IP3 vs. frequency plot.

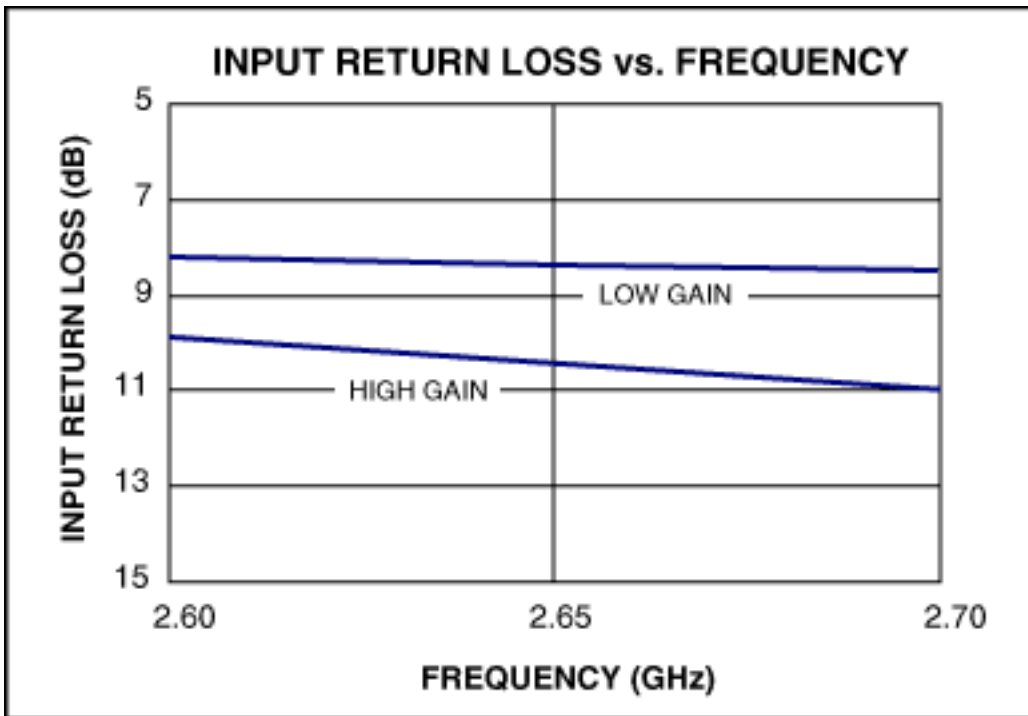

Figure 5. MAX2645 input return loss vs. frequency plot.

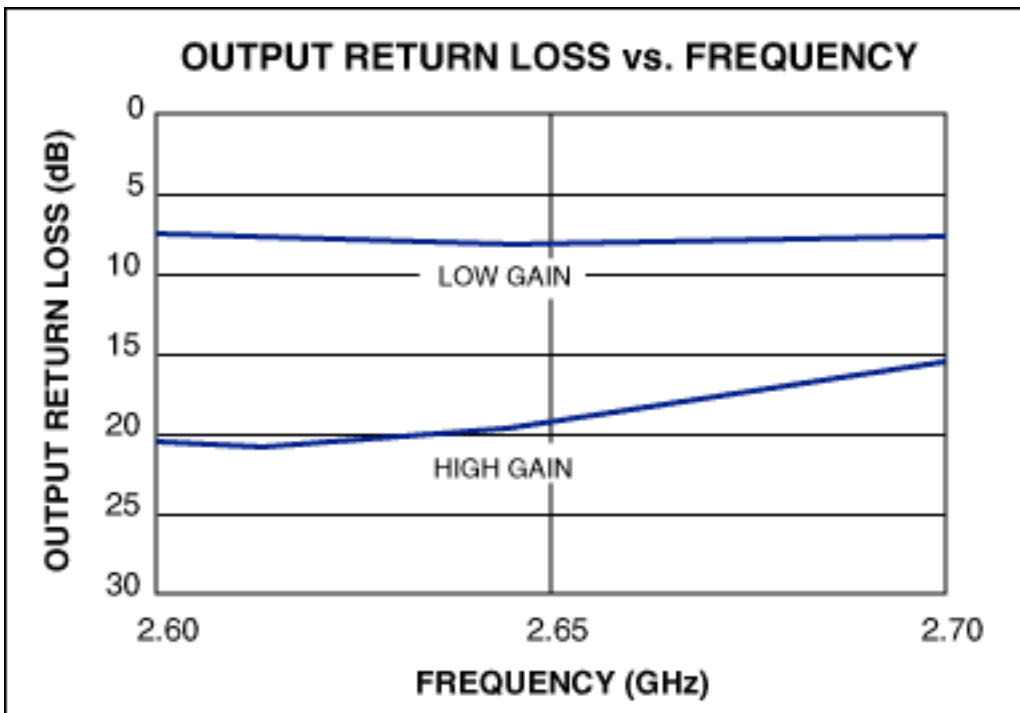

Figure 6. MAX2645 output return loss vs. frequency plot.

Application Note 3042: <http://www.maxim-ic.com/an3042>

#### More Information

For technical questions and support: <http://www.maxim-ic.com/support>

For samples: <http://www.maxim-ic.com/samples>

Other questions and comments: <http://www.maxim-ic.com/contact>

#### Related Parts

MAX2645: [QuickView](#) -- [Full \(PDF\) Data Sheet](#)

AN3042, AN 3042, APP3042, Appnote3042, Appnote 3042

Copyright © by Maxim Integrated Products

Additional legal notices: <http://www.maxim-ic.com/legal>