



APPLICATION NOTE 3039

MAX2388 Front-End IC for WCS Application at 2.3GHz RF and 220MHz IF

Abstract: The MAX2388 front-end IC combines an LNA and a mixer onto one chip. With proper matching, this IC can be used at the WCS band. For this report an RF frequency of 2.3GHz was used with an IF frequency of 220MHz. Traditional receiver measurements were made on the device such as gain, noise figure, IIP3, IIP2, and LO leakage.

General Description

The MAX2388 is a member of a family of receiver front-end devices that also includes the MAX2387 and MAX2389. These devices integrate a low-noise amplifier and a high-linearity downconversion mixer in an ultra-small package, while keeping noise figure at a low level. The MAX2387 and MAX2388 also incorporate an on-chip LO buffer. The MAX2389 omits this LO buffer to minimize current consumption.

The MAX2387 and MAX2388 have been designed for optimal mixer performance with -10dBm LO drive. The MAX2389 mixer performance is optimized for -4dBm typical drive at the LO input port. An external bias resistor controls the tradeoff between mixer 3rd-order nonlinearity and current consumption.

For all devices, both high-gain and low-gain LNA states are featured. The MAX2387 has a 32dB gain step while the MAX2388 and MAX2389 both have an 18dB gain step. A shutdown mode is also included so the IC can be powered down during idle periods, thus increasing battery life.

Although initially designed for the 2110MHz to 2170MHz WCDMA band, these receivers exhibit excellent performance over other frequency ranges as well.

Measured Performance

The measurement data presented here were taken on a standard MAX2388 evaluation kit. The LNA input and output were retuned to be centered at 2315MHz. The mixer matching circuits were tuned for an RF input of 2315MHz, an IF output of 220MHz and low-side LO injection.

Test Conditions

1. $V_{CC} = 2.85V$
2. RF input power = -30dBm
3. RF frequency = 2315MHz; LO frequency = 2095MHz (IF = 220MHz)
4. Two-tone spacing = 1MHz
5. LO power = -10dBm

Table 1. LNA Measurements

Parameter	High Gain	Low Gain	Units
Gain	14.0	3.7	dB
NF	2.35	7.5	dB
IIP3	5.8	3.5	dBm
S11	-12.5	-4.8	dB
S22	-15.8	-7.0	dB
S12	-24.9	-13.5	dB
I _{CC}	10.5	7.3	mA

Table 2. Mixer Measurements

Parameter	High Gain	Low Gain	Units
Gain	7.5	7.3	dB
NF	8.5	7.5	dB
IIP3	5.5	0.0	dBm
IIP2 (Note 1)	27	26.5	dBm
LO leakage at IF port	-17.4	-20.9	dBm
LO leakage at LNA input port	-49.7	-53.9	dBm

Note 1: IIP2 was measured by using the half-IF approach. Using this method the interferer tone was applied at 2205MHz.

LNA S-Parameters

S-parameters for the LNA were measured on a MAX2388 EV kit. The trace lengths from the SMA connectors to the IC pins were de-embedded using the port extension feature of the Network Analyzer.

S-PARAMETERS	LNA	(S11)	LNA	(S21)	LNA	(S12)	LNA	(S22)
FREQUENCY (MHz)	MAGNITUDE	PHASE	MAGNITUDE	PHASE	MAGNITUDE	PHASE	MAGNITUDE	PHASE
600	0.83287	-41.655	5.2176	146.82	0.020023	79.051	0.92461	-15.535
700	0.81889	-43.792	5.0791	145.33	0.021153	78.88	0.9171	-16.23
800	0.80364	-46.486	4.9464	143.26	0.022406	78.412	0.91098	-17.187
900	0.78522	-49.489	4.7767	141.09	0.023962	79.181	0.90108	-18.177
1000	0.76638	-53.118	4.6109	138.2	0.025913	78.989	0.8914	-19.536
1100	0.74542	-56.424	4.4363	135.68	0.027189	79.621	0.87913	-20.759
1200	0.72614	-59.477	4.2861	133.2	0.028484	79.666	0.86957	-22.045
1300	0.70338	-62.232	4.1209	130.93	0.030015	80.686	0.85623	-23.156
1400	0.68291	-64.933	4.0146	128.4	0.030979	81.41	0.84504	-24.46
1500	0.66114	-67.298	3.8951	126.82	0.032236	82.856	0.83313	-25.525
1600	0.63958	-69.782	3.7818	124.53	0.033056	83.763	0.82095	-26.882
1700	0.61641	-72.041	3.6761	122.88	0.03398	85.56	0.80875	-28.147
1800	0.59303	-74.571	3.5823	120.51	0.035009	86.377	0.79497	-29.825
1900	0.56989	-76.974	3.5198	118.87	0.036332	88.572	0.78338	-31.503
2000	0.54509	-79.651	3.4376	116.77	0.036887	89.686	0.76891	-33.44
2100	0.52084	-82.452	3.3691	115.17	0.038318	91.409	0.75735	-35.559
2200	0.49554	-85.891	3.2858	112.47	0.039355	93.409	0.74365	-38.175
2300	0.47232	-89.473	3.2544	110.28	0.040817	94.973	0.73415	-41.034
2400	0.44892	-93.529	3.195	108.05	0.042049	97.086	0.72262	-44.165
2500	0.42766	-98.164	3.1347	105.62	0.043438	98.58	0.71335	-47.828
2600	0.40833	-103.42	3.06	102.94	0.044844	100.14	0.70474	-51.733
2700	0.39421	-109.16	2.9818	100.13	0.046899	101.7	0.70067	-56.04
2800	0.38321	-115.32	2.9149	96.964	0.048389	103.31	0.69795	-60.397
2900	0.37608	-121.52	2.821	94.462	0.049426	104.62	0.69514	-64.899
3000	0.37573	-128.03	2.7086	91.479	0.05079	106.39	0.69504	-69.425
3100	0.38123	-134.23	2.5802	88.528	0.051657	108.22	0.69915	-73.798
3200	0.39208	-139.73	2.4696	85.584	0.053915	110.43	0.70504	-77.625
3300	0.40626	-144.57	2.3296	83.264	0.055483	113.29	0.71095	-81.166
3400	0.42512	-148.8	2.2157	80.95	0.05783	115.29	0.71819	-84.4
3500	0.44708	-152.13	2.0519	79.588	0.060614	118.09	0.72516	-87.06
3600	0.47302	-154.7	1.9382	77.337	0.065129	119.23	0.73416	-89.168
3700	0.49849	-156.57	1.8048	76.594	0.069104	120.99	0.73997	-90.676

Test Setup

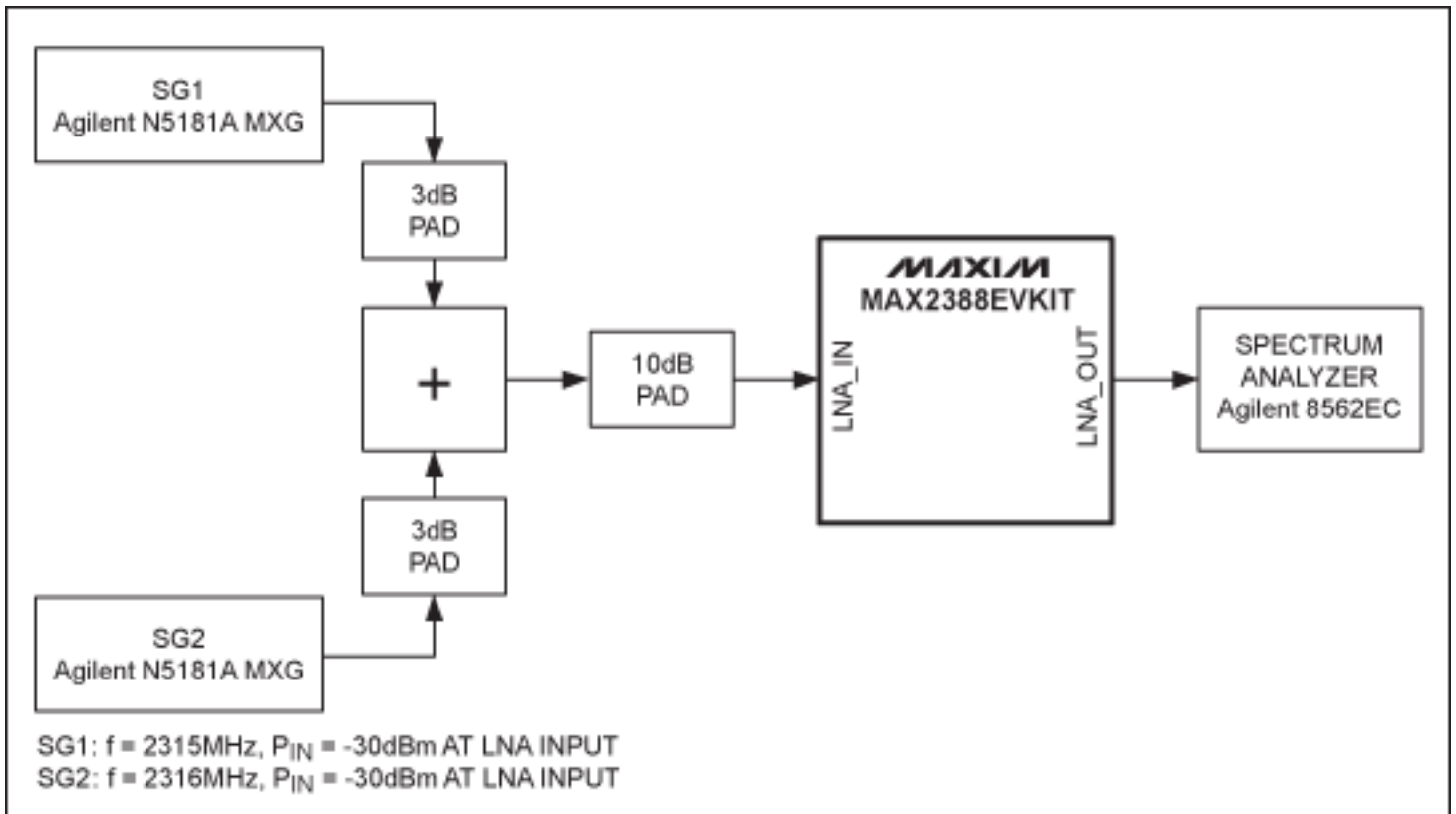

Figure 1. MAX2388 LNA IIP3 measurement.

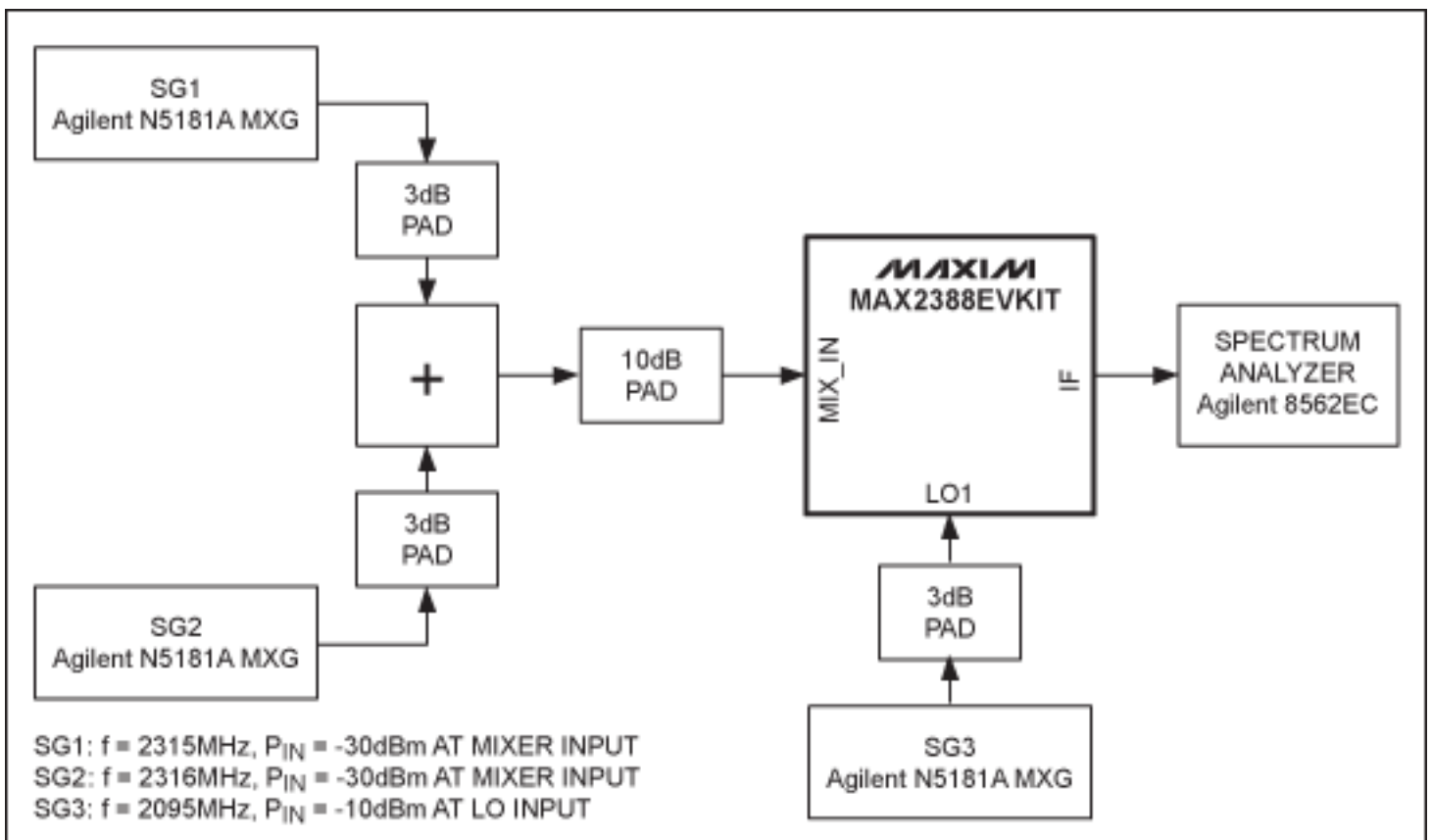

Figure 2. MAX2388 mixer IIP3 measurement.

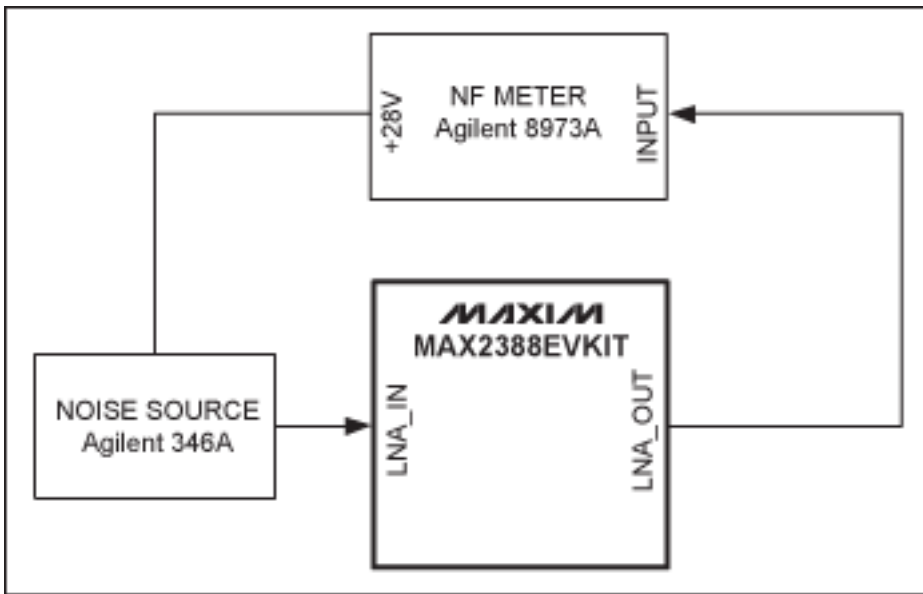

Figure 3. MAX2388 LNA NF measurement.

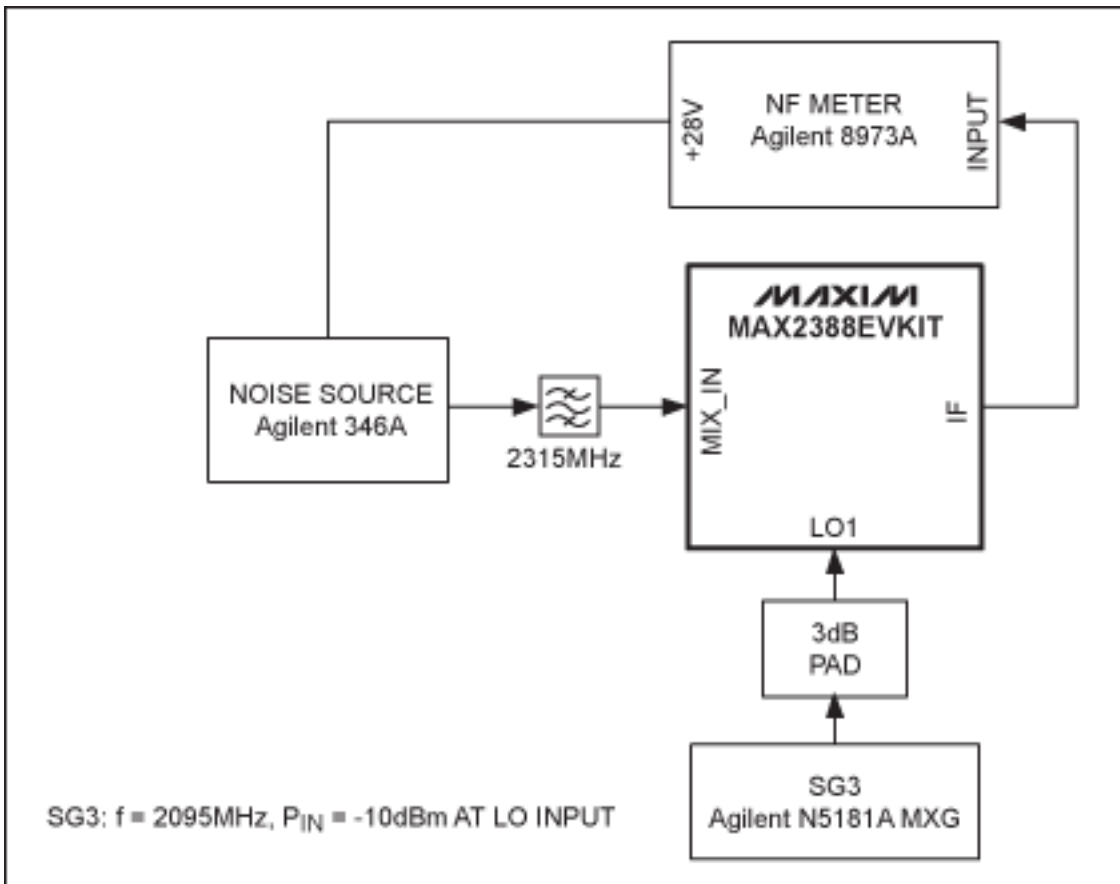

Figure 4. MAX2388 mixer NF measurement.

Application Note 3039: www.maxim-ic.com/an3039

More Information

For technical support: www.maxim-ic.com/support

For samples: www.maxim-ic.com/samples

Other questions and comments: www.maxim-ic.com/contact

Keep Me Informed

Preview new application notes in your areas of interest as soon as they are published. Subscribe to [EE-Mail - Application Notes](#) for weekly updates.

Related Parts

max2387: [QuickView](#) -- [Full \(PDF\) Data Sheet](#) -- [Free Samples](#)

max2388: [QuickView](#) -- [Full \(PDF\) Data Sheet](#) -- [Free Samples](#)

max2389: [QuickView](#) -- [Full \(PDF\) Data Sheet](#) -- [Free Samples](#)

AN3039, AN 3039, APP3039, Appnote3039, Appnote 3039

Copyright © by Maxim Integrated Products

Additional legal notices: www.maxim-ic.com/legal