

APPLICATION NOTE 298

Current-Limit Switch Is Digitally Programmable

Abstract: Current-limit switches are virtually ubiquitous in system controls. They provide a safe means for regulating the current delivered to a load circuit. The switches allow the load current to increase to a programmed limit but no higher. This application note illustrates the implementation of a digitally programmable current-limit switch using MAX890L a current-limited, high-side P-channel switch and MAX5160L digital potentiometer

Additional Information:

- [Quick View Data Sheet for the MAX1983](#)
- [Quick View Data Sheet for the MAX5160](#)
- Powerhelp@design.maxim.com

Current-limit switches are virtually ubiquitous in system controls. They provide a safe means for regulating the current delivered to a load circuit. The switches allow the load current to increase to a programmed limit but no higher. Typically, the current limit is a function of the voltage across an external resistor, produced by the current from a fixed source internal to the switch IC. This voltage serves as the reference for an internal current-limiting amplifier. By replacing the resistor with a digital potentiometer, you can easily program the current limit (see the figure below). IC₁ is a current-limit switch with a maximum programmable limit of 1A. The limit equals $1380/R_{SET}$, where R_{SET} is the resistance between pins 5 and 6 of IC₂. IC₂ is a 50kΩ digital potentiometer whose resistance is programmable in 32 equal increments. With active-low CS held low, high-to-low transitions at active-low INC (pin 1) increments IC₂'s internal counter.

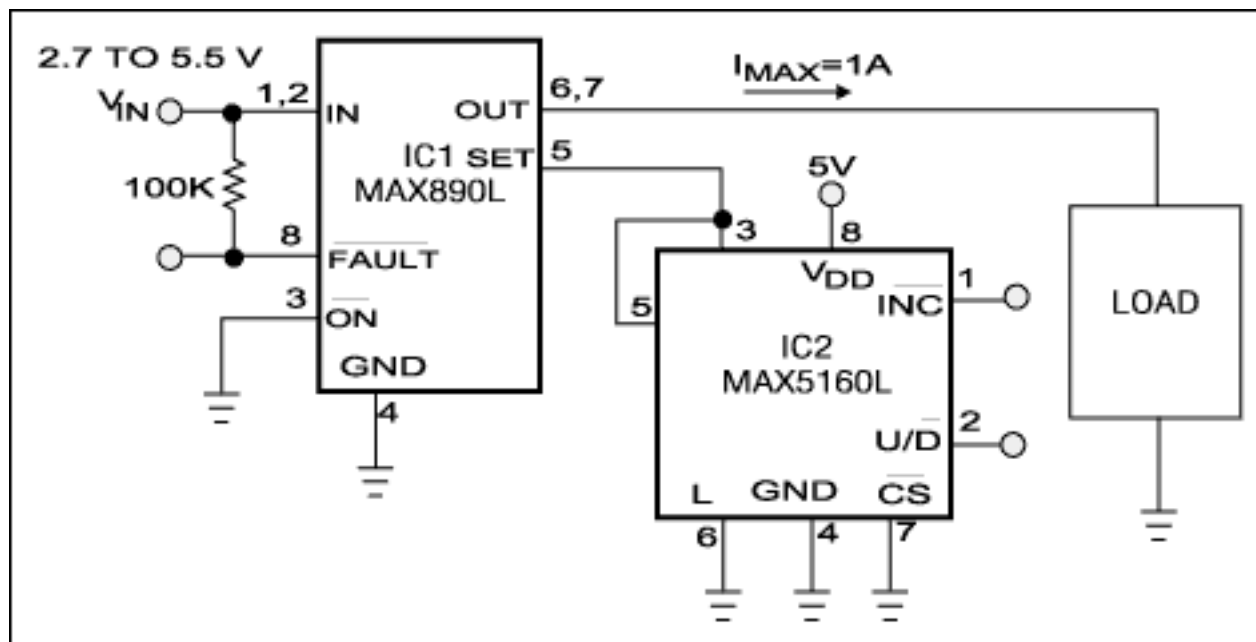

Figure 1. You can program a current limit to 1A in 32 equal increments by using a digital potentiometer.

These transitions increase the resistance between W and L when U/active-low D is low and reduce it when U/active-low D is high. IC₁ includes a thermal-shutdown capability that turns the load current completely off when

the chip temperature exceeds 135°C. It restores the load current when the temperature cools by 10°C. If the short-circuit fault is still present, the switch cycles off and on, yielding a pulsed load current. An open-drain fault output (pin 8) switches low when the load demands current beyond the programmed limit, enabling an external system to monitor the condition of the current switch.

A similar version of this article appeared in the August 17, 2000 issue of *EDN*.

Application Note 298: <http://www.maxim-ic.com/an298>

More Information

For technical questions and support: <http://www.maxim-ic.com/support>

For samples: <http://www.maxim-ic.com/samples>

Other questions and comments: <http://www.maxim-ic.com/contact>

Related Parts

MAX5160: [QuickView](#) -- [Full \(PDF\) Data Sheet](#) -- [Free Samples](#)

MAX890L: [QuickView](#) -- [Full \(PDF\) Data Sheet](#) -- [Free Samples](#)

AN298, AN 298, APP298, Appnote298, Appnote 298

Copyright © by Maxim Integrated Products

Additional legal notices: <http://www.maxim-ic.com/legal>