

APPLICATION NOTE 296

3.3V Supply Taps Power from the -12V PCI Bus

Additional Information:

- [Quick View Data Sheet for the MAX668](#)
- [Samples and Literature Order Form](#)
- [Technical Support: Power](#)

The backplanes of popular multisupply buses (such as VME, VXI, and PCI) each provide power-limited outputs of 3.3V, 5V, and $\pm 12V$ (or $\pm 24V$). If adding line cards to these systems increases the requirements for 3.3V or 5V power, the power budget thus can dictate that a circuit tap its power from the lightly loaded -12V source.

The figure below shows a circuit that derives 3.3V from -12V by boosting the -12V supply to 15.3V (with respect to the -12V rail) and provides up to 300mA. Transistor Q2 level-shifts the 3.3V output to the feedback level of -10.75V.

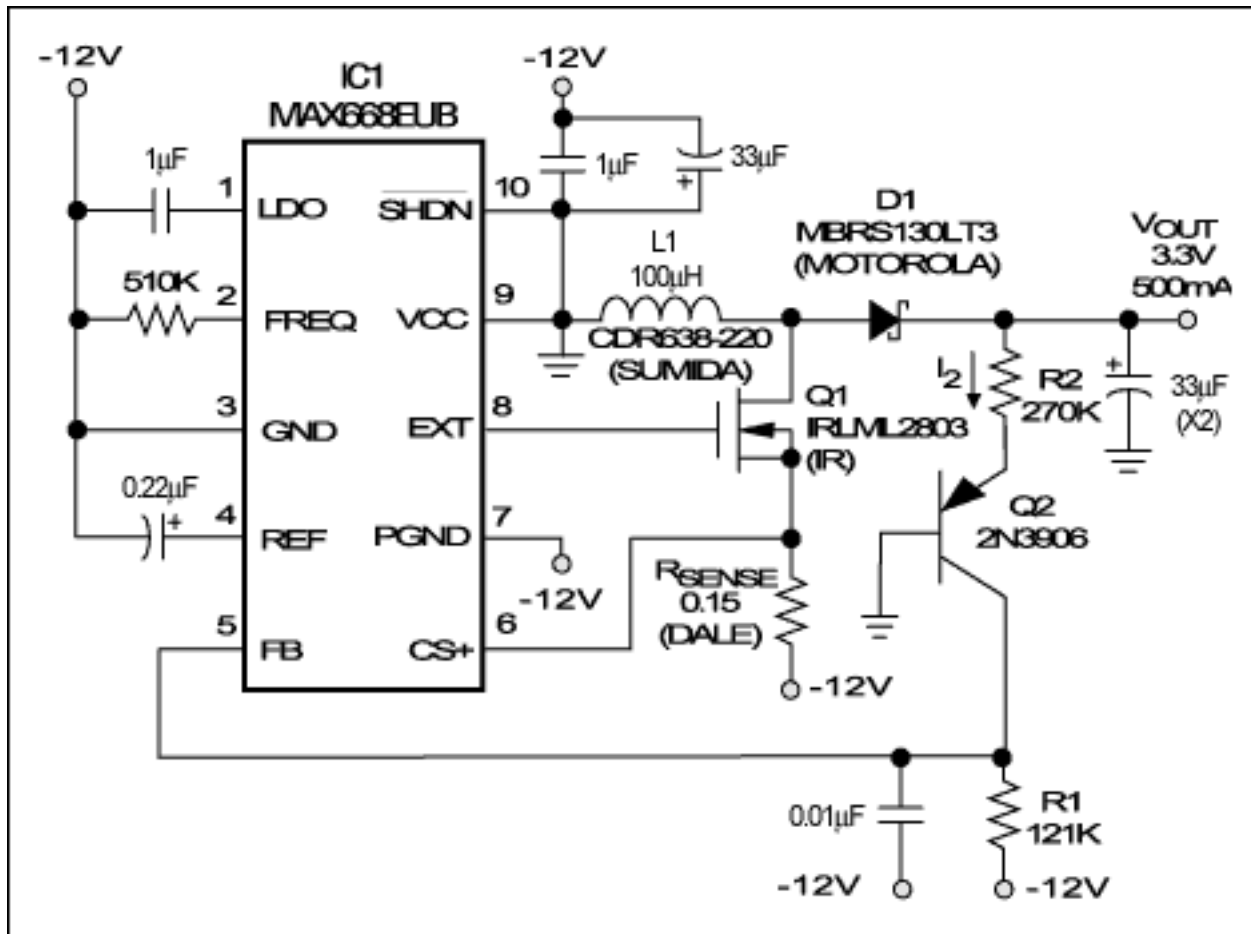

This PWM boost-controller IC provides relief to an overloaded 3.3V backplane supply by generating a supplemental 3.3V regulated output from the lightly loaded -12V rail of a VME, VXI, or PCI backplane.

The circuit occupies approximately 6.25cm² of PC-board space and employs a PWM boost controller that delivers 1W at 83% efficiency levels.

Because the sense resistor (R_{SENSE}) limits peak currents to about 120mA, the n-channel switching MOSFET (Q1) can be an inexpensive logic-level device. Resistors R1 and R2 permit selection of V_{OUT} to either 3.3V or 5V.

Note that the feedback voltage at equilibrium (pin 5, as determined by the trip point of a comparator internal to IC1) is 1.25V above the PGND terminal (pin 7). To calculate the appropriate R1/R2 values:

$$V_{\text{FB}} = -12\text{V} + 1.25\text{V} = -10.75\text{V}$$

Choosing an arbitrary value for R1:

$$I_2 = 1.25\text{V}/R_1 = 1.25\text{V}/12.1\text{k} = 103\mu\text{A}$$

Therefore,

$$R_2 = (V_{\text{OUT}} - V_{\text{BE}})/I_2 = (3.3\text{V} - 0.7\text{V})/103\mu\text{A} = 25.2\text{k}$$

IC1 has another capability that is useful in RF applications, DAQ modules, and other noise-sensitive designs: It lets you program the switching frequency between 100kHz and 500kHz using an external resistor. The circuit's high frequency (100kHz) maintains high efficiency while allowing the use of small inductor and capacitor values.

The circuit is optimized for a 1W output in applications associated with desktop-PC power supplies. In these applications, efficiency must exceed 83%, because the -12V bus is power-limited to 1.2W. If necessary, the output power can be increased to 3W (3V at 1A or more) by scaling L1, D1, and R_{SENSE} . A diode can be added in series with R1 to block unwanted reverse currents.

A similar version of this article appeared in the February 7, 2000 issue of *Electronic Design*.

Application Note 296: www.maxim-ic.com/an296

More Information

For technical support: www.maxim-ic.com/support

For samples: www.maxim-ic.com/samples

Other questions and comments: www.maxim-ic.com/contact

Automatic Updates

Would you like to be automatically notified when new application notes are published in your areas of interest?
[Sign up for EE-Mail™.](#)

Related Parts

MAX668: [QuickView](#) -- [Full \(PDF\) Data Sheet](#) -- [Free Samples](#)

AN296, AN 296, APP296, Appnote296, Appnote 296

Copyright © by Maxim Integrated Products

Additional legal notices: www.maxim-ic.com/legal