

APPLICATION NOTE 2930

HFAN-02.4.0: Over-Voltage Protection for SFP Laser Drivers [Application Brief]

Abstract: Small Form Factor Pluggable (SFP) Modules often require that various safety requirements be met to prevent the optical output from exceeding pre-defined power limits. Using a Zener diode, over-voltage protection can be integrated with the internal safety features of the MAX3740 and MAX3735A SFP laser drivers.

Small Form Factor Pluggable (SFP) Modules often require that various safety requirements be met to prevent the optical output from exceeding pre-defined power limits. The MAX3740 and MAX3735A SFP laser drivers integrate many of these safety features on the IC. These devices are designed to be single-point fault tolerant and also provide adjustable fault levels for the bias and monitor diode currents. These features ensure safe and proper operation when the device is operated within its specified range.

In some SFP applications, it is required that the laser driver be disabled when the supply voltage has exceeded (over-voltage) its normal operating range. Providing over-voltage protection can be easily implemented when using the Maxim SFP laser drivers by placing a Zener diode as shown in **Figure 1**.

The potential of the BIASMON pin of the MAX3740 (Figure 1) is between 0V and 0.8V under normal conditions. If the voltage at BIASMON exceeds approximately 0.8V, a fault is latched and the device shuts down. When the voltage difference between V_{CC} and BIASMON exceeds the reverse breakdown voltage of the Zener diode, current will flow through the diode and into the resistor.

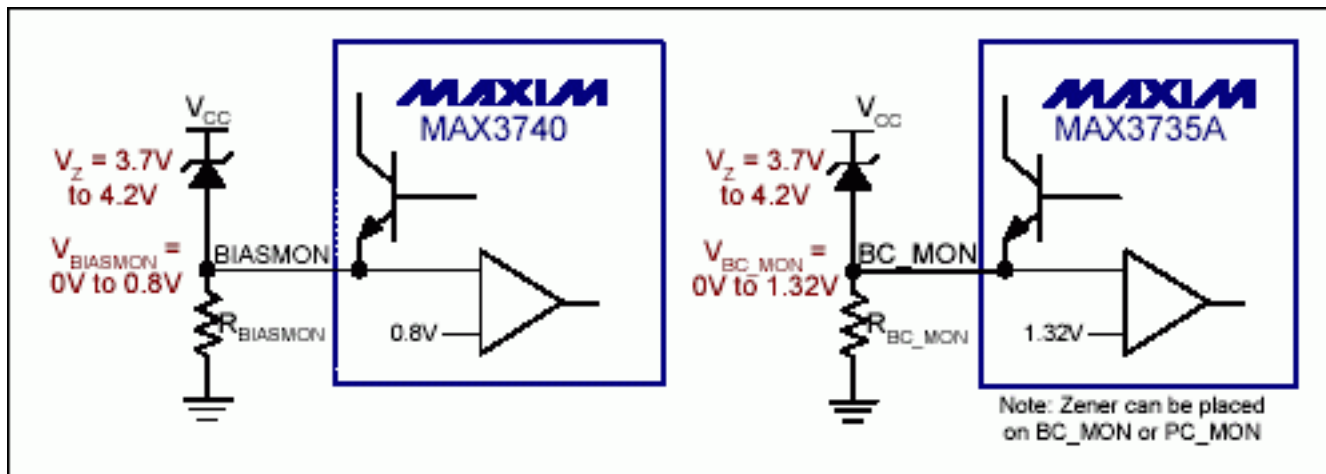

Figure 1. Zener diode placement.

The MAX3740 will then shutdown once the current has caused the voltage at BIASMON to exceed 0.8V. Typically, voltages just slightly above the breakdown point create sufficient current to cause the shutdown condition.

The V_{CC} operating range of the MAX3740 is 2.97V to 3.63 volts. Given this supply range, the Zener diode should be selected to have a reverse breakdown voltage of approximately 3.7V minimum to 4.2V maximum and be rated to an appropriate power level. A Zener diode with a maximum reverse voltage of 4.2V would create a worstcase over-voltage shutdown condition of approximately 5V and a typical shutdown of approximately 4.3V.

For the MAX3735A, a similar procedure can be done. A fault is latched and the MAX3735A shuts down when the

voltage at PC_MON or BC_MON exceeds approximately 1.32V. The diode can be placed on either pin to V_{CC} (Figure 1). Using a diode with similar breakdown specifications as described above would equate to a worst-case breakdown of approximately 5.52V and a typical shutdown of approximately 4.6V.

Note that the supply voltage of the MAX3740 and MAX3735A should not exceed 6V or permanent IC damage may occur. If the over-voltage of the power supply is expected to exceed 6V, another Zener diode and a resettable fuse should be placed on the SFP host board or on the SFP module. (**Figure 2**). The reverse breakdown of this Zener diode should be a maximum of 6.0V. The resettable fuse should be used to limit the current draw from the supply in the event of an over-voltage condition.

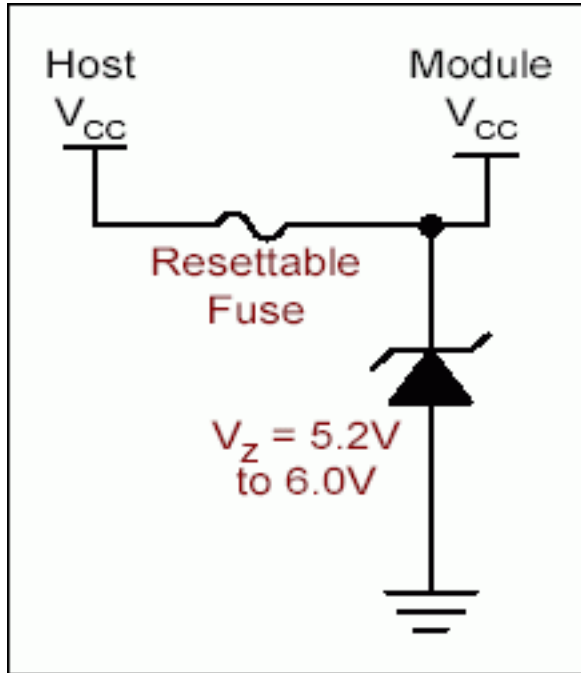

Figure 2. 6.0V limiting circuit.

Application Note 2930: <http://www.maxim-ic.com/an2930>

More Information

For technical questions and support: <http://www.maxim-ic.com/support>

For samples: <http://www.maxim-ic.com/samples>

Other questions and comments: <http://www.maxim-ic.com/contact>

Related Parts

MAX3735A: [QuickView](#) -- [Full \(PDF\) Data Sheet](#) -- [Free Samples](#)

AN2930, AN 2930, APP2930, Appnote2930, Appnote 2930

Copyright © by Maxim Integrated Products

Additional legal notices: <http://www.maxim-ic.com/legal>