

APPLICATION NOTE 2874

2.5GHz LNA with Gain Step for 802.11b/g and Bluetooth Applications

Abstract: This application note presents the design of an LNA at 2.45 GHz for WLAN applications meeting 802.11b/g needs. It presents curves that show gain, noise figure, input and output return loss, and linearity.

The MAX2645 is a Silicon Germanium (SiGe) Low-Noise Amplifier (LNA) that features a 25dB gain step, shutdown mode, and adjustable IP3. The LNA has been optimized to improve the sensitivity of CMOS receivers for 2.4GHz, 802.11b and 802.11g applications. The device features +18.7dB of gain, a noise figure of 1.9dB, and an Input IP3 of +0.5dB in High-Gain Mode. In Low-Gain Mode, the LNA has -7.0dB of insertion loss and an Input IP3 of +15.3dB. Supply current is a low 8.9mA in High-Gain Mode, 2.7mA in Low-Gain Mode and typically 0.1uA in Shutdown Mode. The LNA also features an externally adjustable bias control, set with a single resistor, which allows the user to meet minimum linearity requirements while minimizing current consumption. Table 1 below summarizes MAX2645 performance. The schematic for optimizing the MAX2645 for 2.45GHz is represented in **Figure 1**. **Figures 2-6** demonstrate High-Gain, and Low-Gain performance of the LNA versus frequency. For further information, consult the MAX2645 SiGe LNA and MAX2645 EV kit datasheets.

Table 1. MAX2645 SiGe LNA Performance

Mode	Supply Current (mA)	Gain (dB)	Noise Figure (dB)	Input IP3 (dBm)	Input Return Loss (dB)	Output Return Loss (dB)
High-Gain	8.9	+18.7	1.9	+0.5	-8.3	-15.2
Low-Gain	2.7	-7.0	14.1	+15.3	-11.3	-8.5

(f = 2.45GHz, V_{CC} = 3.0V, R_{BIAS} = 20kΩ)

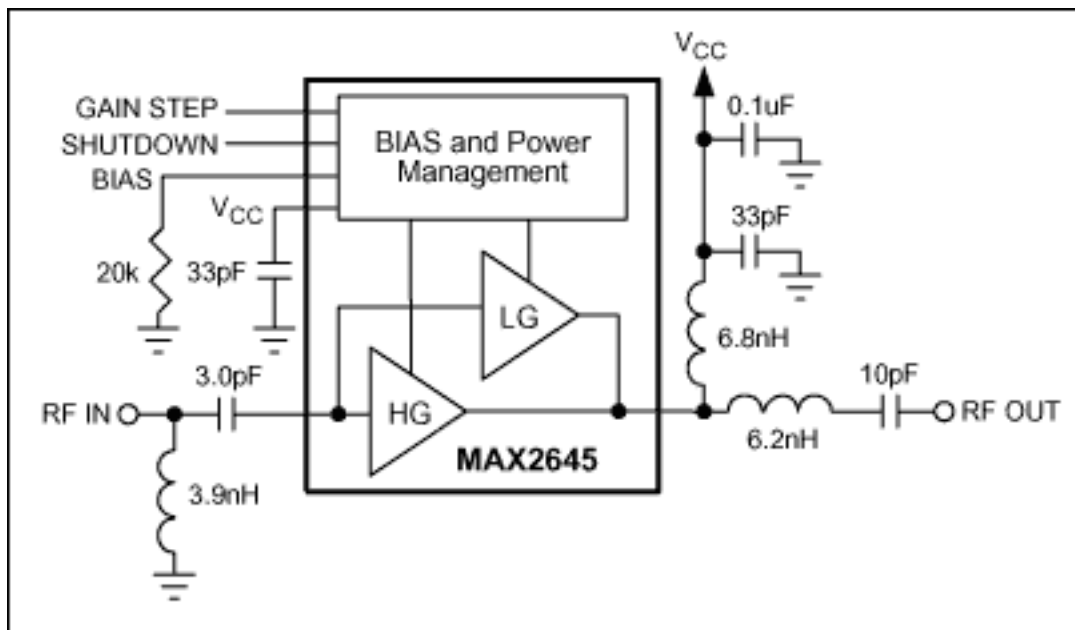

Figure 1. MAX2645 SiGe LNA 2.45GHz LNA schematic.

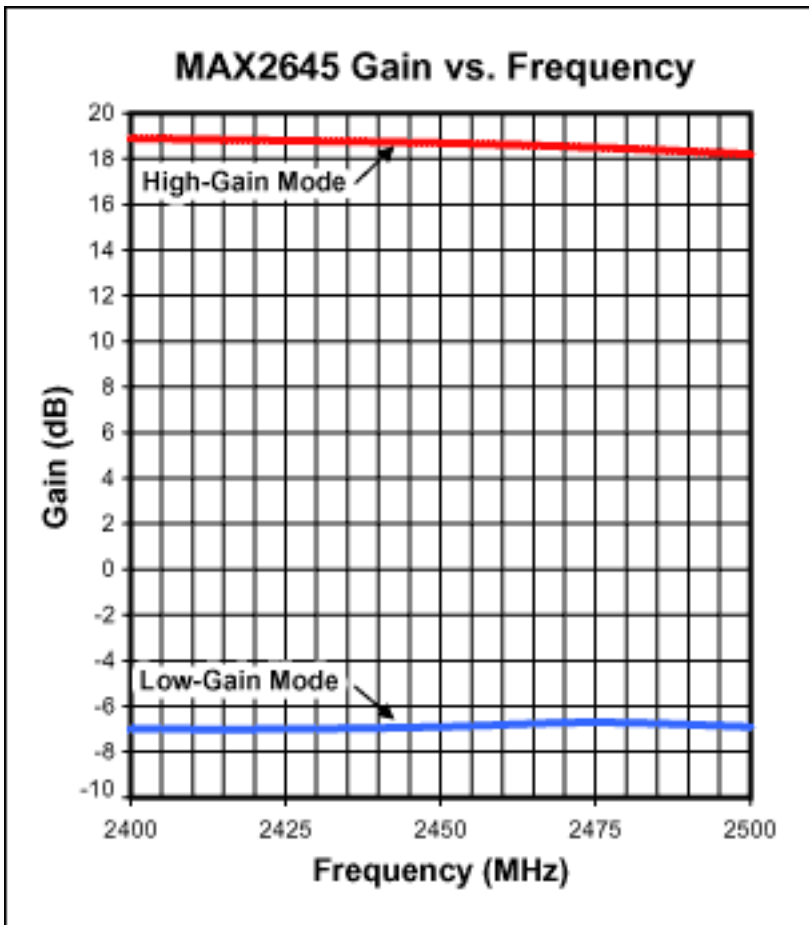

Figure 2. MAX2645 Gain versus frequency ($V_{CC} = 3.0V$, $R_{BIAS} = 20k\Omega$).

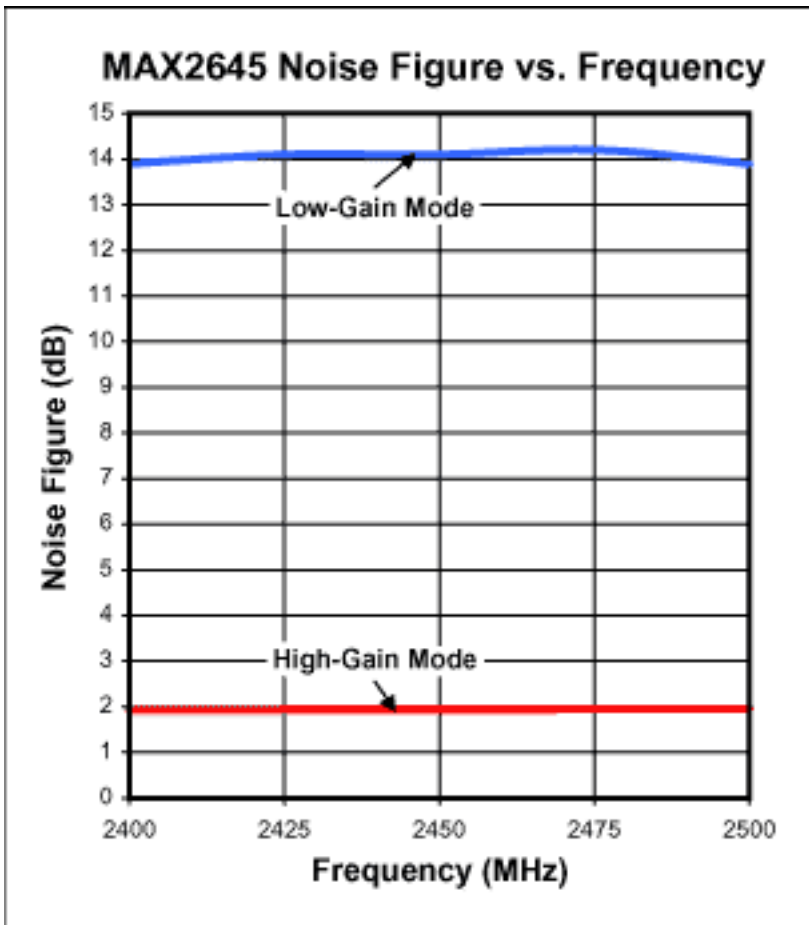

Figure 3. MAX2645 Noise figure versus frequency ($V_{CC} = 3.0V$, $R_{BIAS} = 20k\Omega$).

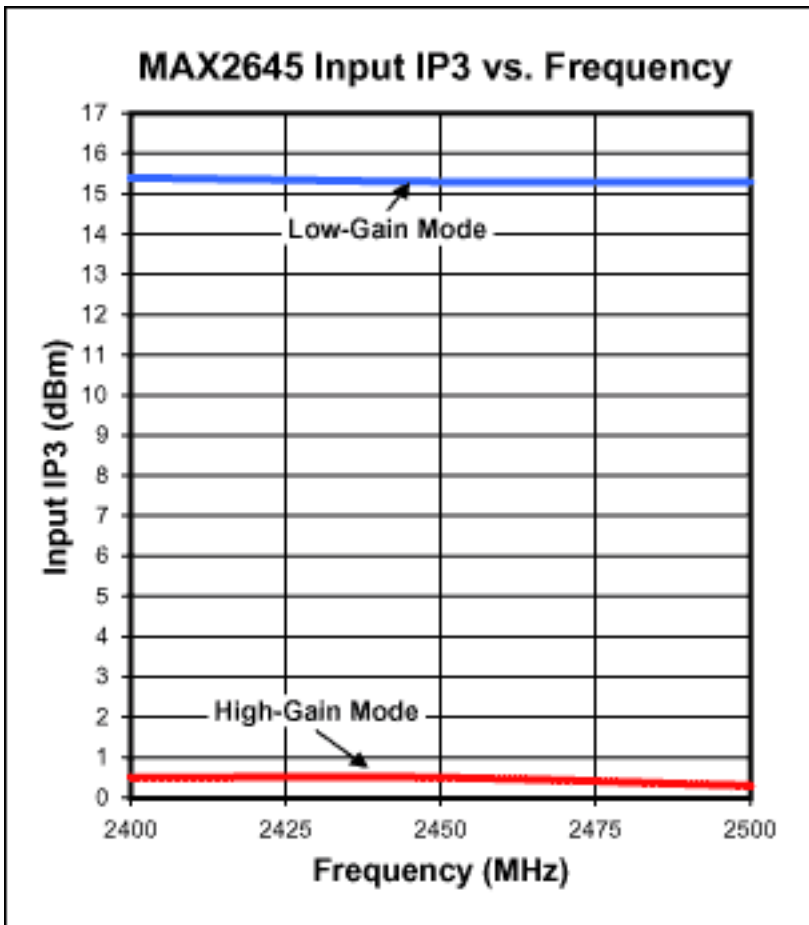

Figure 4. MAX2645 Input IP3 versus frequency ($V_{CC} = 3.0V$, $R_{BIAS} = 20k\Omega$).

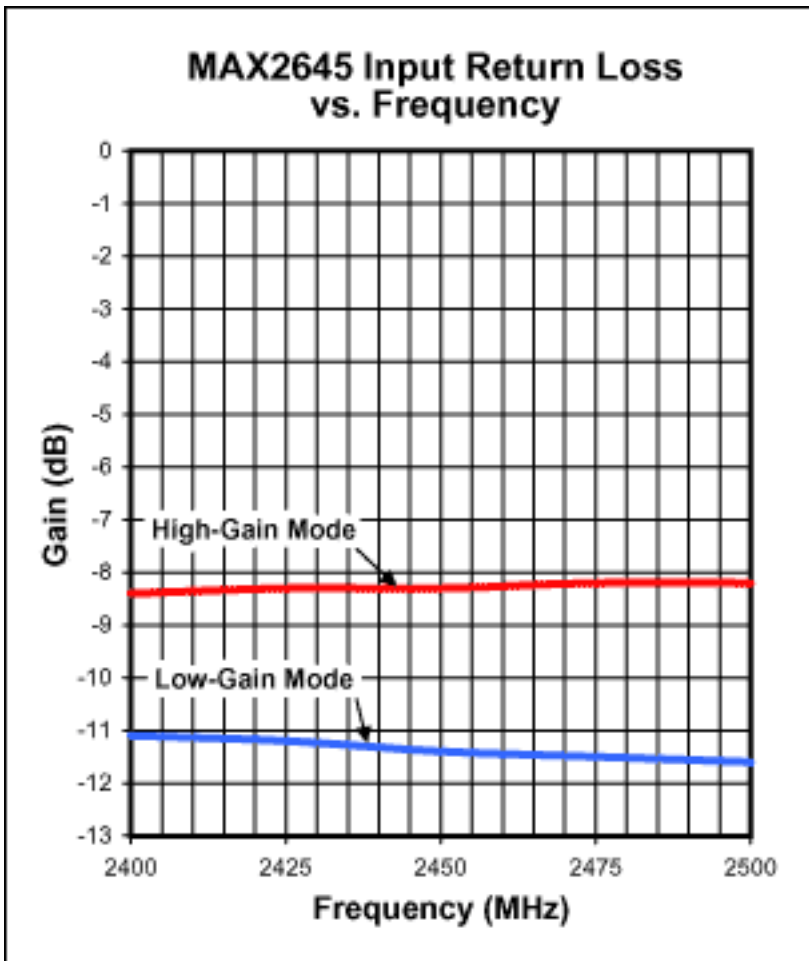

Figure 5. MAX2645 Input Return Loss Versus Frequency ($V_{CC} = 3.0V$, $R_{BIAS} = 20k\Omega$).

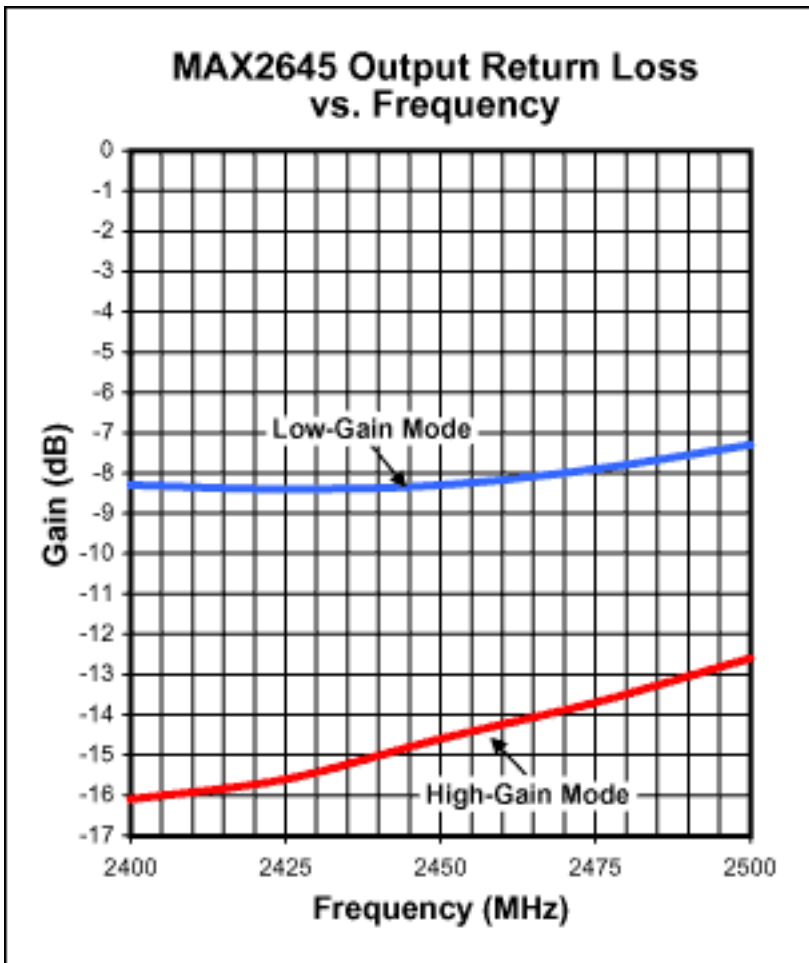

Figure 6. MAX2645 Output return loss ($V_{CC} = 3.0V$, $R_{BIAS} = 20k\Omega$).

Application Note 2874: <http://www.maxim-ic.com/an2874>

More Information

For technical questions and support: <http://www.maxim-ic.com/support>

For samples: <http://www.maxim-ic.com/samples>

Other questions and comments: <http://www.maxim-ic.com/contact>

Related Parts

MAX2645: [QuickView](#) -- [Full \(PDF\) Data Sheet](#)

AN2874, AN 2874, APP2874, Appnote2874, Appnote 2874

Copyright © by Maxim Integrated Products

Additional legal notices: <http://www.maxim-ic.com/legal>