

APPLICATION NOTE 2869

Tune the MAX2530 LNA for 450MHz CDMA2000 Operation

This application note describes how to tune the MAX2530 LNA to perform in a 450MHz CDMA application. Its performance and features at 450MHz are described and we present a practical circuit and measurement data.

Overview

Cellular telephone companies are now designing CDMA handsets for the European market at 450MHz, which was previously used for analog communication in Europe. RF designers developing a 450MHz CDMA cellular phone or wireless modem face the challenge of choosing a front-end chip set with the best performance to meet their system specification.

The MAX2530 receiver RF front-end IC, using Maxim's advanced SiGe process, was originally designed for cellular-band and PCS band operation. For 450MHz CDMA, the NF (noise figure) and the IIP3 (input third-order intercept) of the low noise amplifier (LNA) are very critical in considering the sensitivity, and the single-tone desensitization effect. This technical note gives the tuning method and measurement data for using the MAX2530 in a 450MHz cdma2000® application.

Design Constraints

Using external matching components, re-tune the MAX2530's Cellular LNA for operation within the following guidelines:

- Operating Frequency = 463MHz to 467.5MHz
- Gain = 13.8 to 14.5dB
- NF = 1.8 to 2.2dB
- IIP3 = 4.0 to 5.0dBm
- $|S_{11}| = < -10\text{dB}$
- $|S_{22}| = < -10\text{dB}$

Methodology

The IIP3 and NF of the LNA are influenced by the input and output matching circuit and quiescent bias current. During tuning of the LNA, a microwave tuner was placed on the input or output of the LNA and adjusted for optimum performance. The tuner was then removed and the associated matching components are changed with the aim of achieving the same input/output return loss and impedance as noted with the tuner. This process was performed one port at a time (i.e.- the best input match was determined and fixed then the focus shifted to the output). As an added variable, R_{BIAS} was replaced with a 20k Ω potentiometer that could be used to quickly identify the best bias setting for any given match.

Results

Testing numerous combinations of matching components and bias settings (approx. 40 different combinations)

yielded a few possible solutions. The results from one such combination follows:

Solution A

- $V_{CC} = 3.0\text{VDC}$
- $I_{CC} = 42.2\text{mA}$
- Gain = 14.0dB
- NF = 2.3dB
- IIP3 = 5.6dBm
- $S_{11} = -12.5\text{dB}$
- $S_{22} = -8.1\text{dB}$

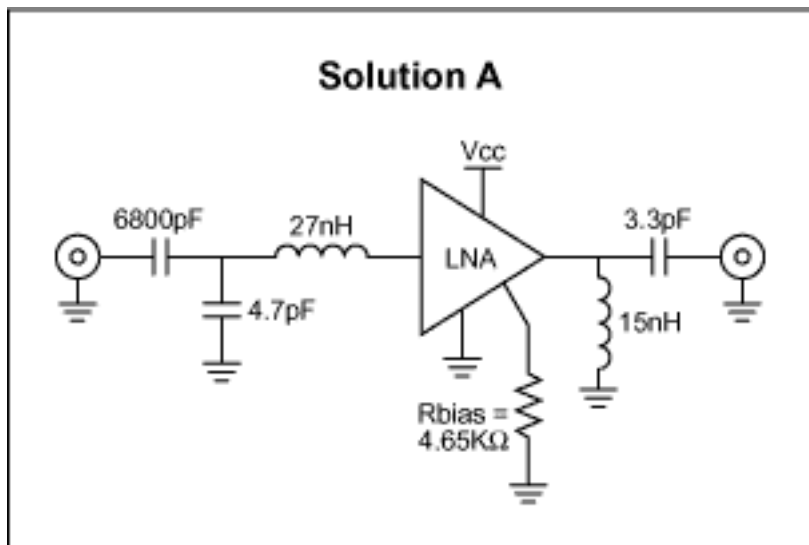

Figure 1.

While the Noise Figure shown is 0.1dB above the objective, the PCB has an insertion loss of approx. 0.06dB from the SMA connector to the DC blocking cap at 465MHz. This has not been de-embedded from the measurement. So the actual NF is closer to 2.24dB.

A slightly different input match and bias setting provided a minor improvement in NF but degraded IIP3:

Solution B

- $V_{CC} = 3.0\text{VDC}$
- $I_{CC} = 40.5\text{mA}$
- Gain = 14.0dB
- NF = 2.23dB
- IIP3 = 5.0dBm
- $S_{11} = -13.8\text{dB}$
- $S_{22} = -8.0\text{dB}$

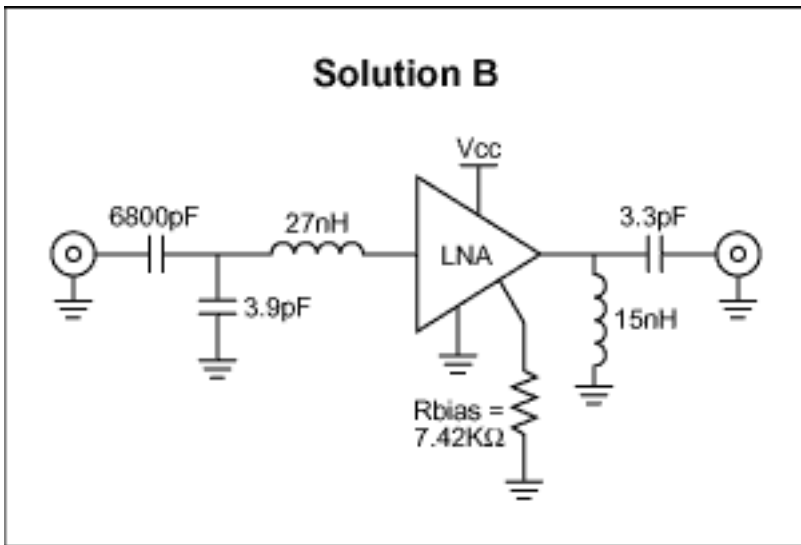

Figure 2.

Subtracting the insertion loss from Noise figure yields about 2.17dB.

For both matches shown above the bias setting did affect the NF and IIP3 performance. An increase in the bias resistor value reduces the bias current and improves the NF (to as low as 1.8dB) but also degrades linearity. By this method the two parameters can be balanced for system requirements. If more linearity is required but a higher Noise Figure can be tolerated, a lower bias resistor value can be used. Unfortunately, linearity is much more sensitive to bias changes than NF so the range and effectiveness of adjustment is limited.

The following table displays the two solutions discussed above

Parameter	Maxim Objective	Solution A (MAX2530)	Solution B (MAX2530)	Units
V _{CC}	3.0	3.0	3.0	VDC
I _{CC}	tbd	42.2	40.5	mA
Gain	13.8 to 14.5	14.0	14.0	dB
NF	1.8 to 2.2	2.24	2.17	dB
IIP3	4.0 to 5.0	5.6	5.0	dBm
S ₁₁	< -10	-12.5	-13.8	dB
S ₂₂	< -10	-8.1	-8.0	dB

Receiver System Cascade Analysis

Based on the previous optimum measurement results of MAX2530 LNA and Mixer, the receiver system cascade analysis is done with spreadsheet file, it is shown that the Eb/Nt = 5.0dB, which meets the system specification requirement for Eb/Nt = 4.3dB with 0.7dB margin.

References

1. "3rd Generation Partnership Project 2, Recommend Minimum Performance Standards for cdma2000 Spread Spectrum Mobile Stations."
2. Ali-Ahmad, Walid Y., "RF system issues related to CDMA receiver specification," RF Design, September, 1999.

Application Note 2869: <http://www.maxim-ic.com/an2869>

More Information

For technical questions and support: <http://www.maxim-ic.com/support>

For samples: <http://www.maxim-ic.com/samples>

Other questions and comments: <http://www.maxim-ic.com/contact>

Related Parts

MAX2530: [QuickView](#) -- [Full \(PDF\) Data Sheet](#)

AN2869, AN 2869, APP2869, Appnote2869, Appnote 2869

Copyright © 2005 by Maxim Integrated Products

Additional legal notices: <http://www.maxim-ic.com/legal>