



APPLICATION NOTE 286

The MAX2683 Low-Cost High-Performance 3.5GHz Upconverter

Abstract: This application note describes the features of the MAX2683 3.5GHz upconverter. A typical schematic is given with the matching components for 3.55GHz output, 1.6GHz LO and 350MHz input. The noise figure is ~12.5dB, and the conversion gain is 8.6dB. The integrated circuit (IC) can also be used for a downconverter. Links to tables of S-parameters are provided to aid the design engineer.

Additional Information:

- [Wireless Product Line Page](#)
- [Quick View Data Sheet](#)
- [Applications Technical Support](#)

Introduction

The MAX2683 is a double-balanced active mixer based on the Gilbert cell that is capable of accepting RF inputs up to 3.5GHz and producing IF outputs up to 3.6GHz. It features an adjustable bias control, conversion gain, insensitivity to mismatch, and superior isolation in a very compact format.

This application note presents a brief description of the mixer, design tips, and typical performance features for the MAX2683.

Upconverter Review

A fundamental property of mixers is frequency conversion. This property is put to use in virtually all transmitters. For typical operation, a modulating signal operating at a frequency of f_{MOD} is injected into one port of the mixer, and a local oscillator (LO) signal at a frequency of f_{LO} is injected into a second port. The resulting output radio frequency (RF) signal is upconverted to a frequency of $f_{MOD} + f_{LO}$. Frequency conversion results from a multiplication of the modulated f_{MOD} waveform, $\cos(f_{MOD} * t)$, and LO waveform. From trigonometry, we have the following:

$$\cos(f_{MOD} * t) * \cos(f_{LO} * t) = 1/2 \cos(f_{LO} - f_{MOD}) \pm 1/2 \cos(f_{LO} \pm f_{MOD})$$

In this ideal multiplication, the output of the mixer contains only signals at frequencies $f_{LO} - f_{MOD}$ and $f_{LO} + f_{MOD}$; that is, the original modulation signal f_{MOD} and the local signal f_{LO} are completely suppressed at the upconverter output RF port.

The Gilbert cell active mixer is based on an emitter-coupled-pair amplifier. The operation of this amplifier is best understood by dividing the modulated signal into its common-mode and differential-mode components. The modulated signal enters one side of the pair, while the opposite side is AC-grounded through a capacitor. From symmetry, the common-mode component shifts the current between the two branches and, for small signals, acts as a standard common-emitter amplifier. The MAX2683 employs four cross-coupled devices to the basic amplifier to multiply the modulated signal by \pm at the LO rate and to achieve the desired double-balanced mixer

characteristics. The combination of these devices with the emitter-coupled pair completes the basic Gilbert cell. As with the modulated signal input, the LO is injected in a single-ended fashion with the opposite side AC-grounded through a capacitor. The positive LO voltages cause the outer set of the device to be on, resulting in a multiplication of the modulated signal by \pm at the LO rate, while negative voltages cause the inner pair to be on, also multiplying the modulated signal by \pm at the LO rate.

Product Design and Performance Features

The MAX2683 operates from a single +2.7V to +5.5V supply. The device is available in an ultra-small 16-pin TSSOP-EP package with an exposed paddle for the special application up to 3.6GHz. It uses a double-balanced Gilbert cell architecture with single-ended RF and LO inputs and differential open-collector output ports. Differential output ports provide a wideband, flexible interface for either single-ended or differential applications. The MAX2683 features an adjustable bias control, set with an external resistor, that lets the user trade supply current for linearity to optimize system performance. A logic-level control enables an internal frequency doubler on this device, allowing the external local oscillator source to run at full or half frequency. An internal LO filter reduces LO harmonics and spurious mixing. **Figure 1** is a simplified block diagram of a MAX2683 application. **Figure 2** is a pin description of the MAX2683. The details of consequent performance features are described below.

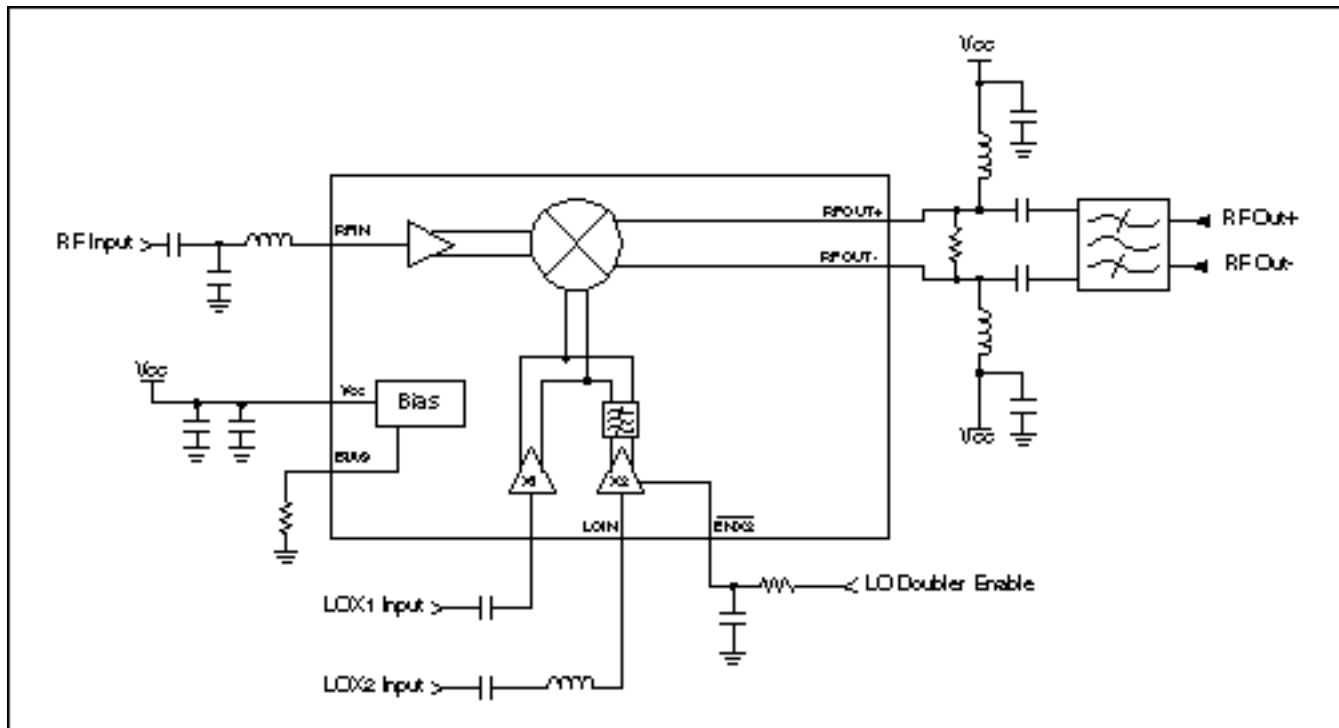

Figure 1. Simplified block diagram of a MAX2683 application.

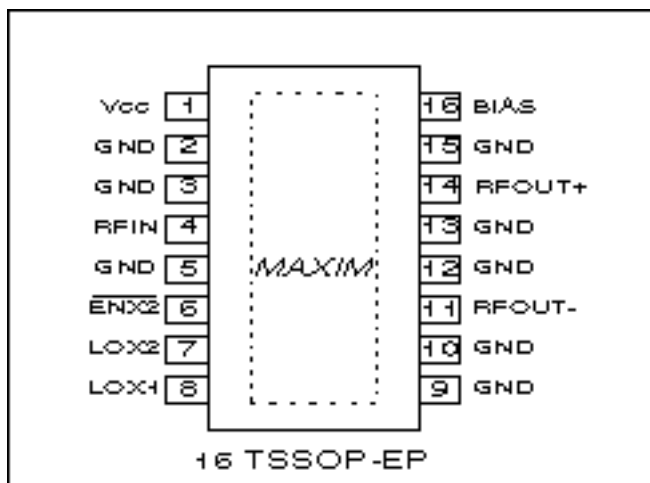

Figure 2. Pin description of the MAX2683.

DC Bias

The MAX2683 requires a DC bias. Whereas conventional passive mixers use AC signals to create device conduction, active Gilbert cell mixers require a DC power supply. DC bias is applied to the device in the form of a voltage V_{CC} . Enough voltage must be applied to cause the transistors in the Gilbert cell to conduct, otherwise the desired switching action will not occur. The minimal voltage required for the mixer to operate is 2.7V. As V_{CC} is increased, the simple bias scheme allows the transistors to turn on harder. The gain of the mixer increases, as does the compression point. Because change in bias affects linearity, such changes alter the levels of harmonic and spurious signals produced by the mixer. Bias changes also affect f_t of the transistors in the chip and hence the frequency range over which the mixer operates. The linearity and supply current of the MAX2683 is externally programmable with a single resistor, BIAS, from BIAS to GND. A nominal resistor value of 1.2k Ω will set the supply current of 55mA. Decreasing the resistor value improves linearity at the cost of increasing the supply current. Increasing the resistor value decreases the supply current while degrading linearity. Use a resistor value in the range of 820 Ω to 2.0k Ω .

Gain

The MAX2683 has conversion gain, so in conventional use the output signal will be at a higher power level than the input signal. Most of the gain in the MAX2683 comes from the emitter-coupled amplifier in the Gilbert cell. The amount of gain achieved will vary with the frequency, the temperature of the operation, the oscillator signal, and the bias level. In order to optimize the gain and the linearity, a properly designed PC board is an essential part of any RF/microwave circuit. Keep RF signal lines as short as possible to reduce losses, radiation, and inductance. Use separate, low inductance vias to the ground plane for each ground pin. For best performance, solder the exposed pad on the bottom of the device package to the board ground plane. The differential open-collector RFOUT- and RFOUT+ ports require external pullup inductors to V_{CC} , as well as an output matching network for optimum gain performance. The S-parameters of modulated signal input, LO input, and RF output are shown in Table 2. Designers can refer to that table to develop optimized matching circuits to meet their system specifications.

Oscillator Signals

The MAX2683 requires low oscillator drive levels. In the mixer based on the Gilbert cell, the primary function of the LO signal is to switch the conduction path between the outer and inner transistors of the cross-coupled quad. This requires relatively little power. In general, the spurious response of a Gilbert cell mixer will improve at a lower oscillator drive level. Increasing the LO power to the MAX2683 upconverter will saturate (actually, "quasi-saturate") the transistors of the quad and emitter-coupled pair, and decrease linearity. As the LO drive level is decreased from a nominal characterization value, there is a 5dB to 10dB range over which conversion gain is not affected significantly. When the LO drive level is reduced still further, conversion gain will "roll off." No sinusoidal LO signals can have frequency components at many (harmonically related) frequencies. A typical LO input power is -5dBm at 50 Ω matching for the MAX2683.

Operating Frequency Range

The MAX2683 operates over a very wide frequency range. It can operate as a downconverter or an upconverter. The frequency of the modulated signal through the Gilbert cell quad can go up to 3.8GHz. The output frequency range can reach 3.6GHz if a proper output matching network is provided. The MAX2683 features an internal LO frequency doubler that allows the external LO to run at full or half frequency. Running the LO at half frequency has the benefit of reducing unwanted LO leakage through the amplifier to the antenna. An internal LO band pass filter is integrated after the frequency doubler to help reduce LO harmonic content and spurious mixing. To enable the LO frequency doubler, drive ENX2 to a logic low level and connect the half-frequency external LO to the LOX2 port. To disable and bypass the LO frequency doubler and LO filter, drive ENX2 to a logic high level and connect the full-frequency external LO to the LOX1 port. Disabling the LO doubler has the benefit of reducing the

supply current by 15mA. The maximum frequency range of LOX1 is up to 3.9GHz, and the LOX2 frequency range is up to 1.95GHz.

Noise Figure

The Gilbert cell structure is not a low-noise configuration. The mixer noise figure comes primarily from the shot noise of the four collector-cross-coupled transistors, the noise of both transistors in the emitter-coupled pair, and the thermal noise of both feedback resistors used with the emitter-coupled pair. The switching action of the LO can affect the mixer noise figure when there is very low input LO power. The typical noise figure of the MAX2683 is close to 12.5dB.

Matching Circuit

Three ports need to be matched properly in order to achieve optimum performance. Table 1 provides a complete S-parameter for three ports, the frequency range covered from 50MHz to 6GHz. The designer can refer to this table to choose the best matching circuit to meet system specifications. This application note includes an application schematic that shows a typical matching circuit for three ports. The input port is matched to 350MHz frequency, the LO port is matched to 1.6GHz, and the output port is matched to 3.55GHz.

Table 1. S-Parameters of the MAX2683

Table 1.1. F Input S_{11} -Parameter

FREQ.	5VDC	5VDC	3.3VDC	3.3VDC		FREQ.	5VDC	5VDC	3.3VDC	3.3VDC
(MHz)	Amplitude	Degree	Amplitude	Degree		(MHz)	Amplitude	Degree	Amplitude	Degree
50	0.868	-4.4	0.868	-4.5		3050	0.566	-147.1	0.557	-154.6
100	0.851	-7.7	0.850	-7.9		3100	0.563	-147.5	0.555	-157.1
150	0.817	-13.9	0.813	-16.4		3150	0.562	-151.9	0.556	-159.2
200	0.801	-10.1	0.797	-11.6		3200	0.544	-154.3	0.559	-162.4
250	0.816	-11.8	0.814	-12.5		3250	0.568	-156.6	0.564	-164.7
300	0.831	-21.1	0.830	-22.5		3300	0.574	-160.0	0.572	-167.1
350	0.791	-22.4	0.789	-25.0		3350	0.583	-162.0	0.582	-169.4
400	0.770	-27.4	0.578	-30.0		3400	0.593	-164.0	0.592	-171.2
450	0.710	-27.2	0.639	-30.6		3450	0.604	-167.3	0.603	-174.2
500	0.715	-28.3	0.700	-29.9		3500	0.617	-169.1	0.616	-176.4
550	0.713	-30.8	0.701	-32.2		3550	0.631	-171.4	0.636	-178.7
600	0.705	-33.3	0.691	-34.8		3600	0.644	-173.8	0.644	179.0
650	0.698	-35.8	0.688	-37.5		3650	0.657	-176.2	0.656	176.3
700	0.690	-38.4	0.680	-40.1		3700	0.669	-178.8	0.665	173.5
750	0.682	-40.9	0.672	-42.6		3750	0.678	178.6	0.672	170.8
800	0.672	-43.1	0.662	-44.9		3800	0.685	175.8	0.677	168.1
850	0.665	-45.0	0.654	-47.0		3850	0.688	172.2	0.677	165.2
900	0.660	-47.0	0.648	-49.1		3900	0.689	170.1	0.674	162.0
950	0.654	-49.1	0.643	-51.3		3950	0.684	167.0	0.666	158.9
1000	0.651	-50.9	0.638	-52.0		4000	0.675	164.0	0.654	155.0
1050	0.635	-55.1	0.623	-58.0		4050	0.661	163.3	0.639	136.0

1100	0.635	-58.1	0.622	-61.5	4100	0.648	160.1	0.624	153.7
1150	0.633	-60.3	0.618	-63.6	4150	0.632	158.2	0.608	151.2
1200	0.631	-61.9	0.617	-65.6	4200	0.615	155.7	0.591	148.8
1250	0.631	-63.5	0.619	-67.1	4250	0.599	152.2	0.575	146.5
1300	0.633	-65.2	0.618	-68.6	4300	0.584	151.9	0.561	144.4
1350	0.633	-66.7	0.615	-70.4	4350	0.571	149.7	0.550	142.4
1400	0.630	-68.7	0.615	-72.4	4400	0.561	147.8	0.541	140.7
1450	0.630	-70.7	0.615	-74.5	4450	0.553	146.7	0.535	139.0
1500	0.630	-72.7	0.614	-76.5	4500	0.549	144.2	0.532	137.1
1550	0.629	-74.8	0.614	-78.1	4550	0.547	140.5	0.532	133.4
1600	0.627	-77.3	0.612	-81.0	4600	0.548	138.8	0.534	131.8
1650	0.622	-79.9	0.607	-82.2	4650	0.552	137.3	0.541	130.4
1700	0.619	-82.5	0.604	-85.9	4700	0.558	135.9	0.548	129.1
1750	0.618	-85.0	0.604	-89.4	4750	0.566	134.4	0.556	127.5
1800	0.618	-87.6	0.605	-92.1	4800	0.577	133.1	0.569	126.2
1850	0.616	-90.5	0.604	-95.0	4850	0.589	131.7	0.581	124.9
1900	0.615	-93.3	0.602	-98.2	4900	0.604	130.4	0.595	123.6
1950	0.612	-96.0	0.600	-101.0	4950	0.616	128.9	0.607	122.1
2000	0.612	-98.7	0.601	-103.2	5000	0.628	127.3	0.619	120.4
2050	0.609	-96.7	0.600	-100.9	5050	0.671	127.8	0.644	120.9
2100	0.614	-98.1	0.605	-102.6	5100	0.660	127.9	0.644	121.2
2150	0.620	-100.0	0.613	-105.1	5150	0.663	127.7	0.647	121.1
2200	0.626	-102.0	0.618	-107.5	5200	0.668	127.2	0.651	120.1
2250	0.634	-105.1	0.626	-109.9	5250	0.671	126.2	0.654	119.4
2300	0.640	-107.5	0.632	-112.4	5300	0.674	124.3	0.653	117.9
2350	0.644	-110.1	0.636	-115.1	5350	0.672	123.1	0.650	116.1
2400	0.647	-112.2	0.636	-118.1	5400	0.668	121.4	0.644	114.3
2450	0.642	-115.0	0.634	-121.0	5450	0.659	119.4	0.632	112.4
2500	0.645	-116.7	0.632	-123.9	5500	0.647	117.7	0.618	110.9
2550	0.642	-119.3	0.626	-126.7	5550	0.633	116.4	0.603	108.0
2600	0.636	-122.0	0.616	-129.5	5600	0.620	114.6	0.591	107.4
2650	0.627	-124.4	0.604	-132.1	5650	0.608	113.1	0.581	106.5
2700	0.616	-127.1	0.596	-134.3	5700	0.598	111.4	0.572	105.2
2750	0.608	-129.2	0.590	-136.4	5750	0.587	109.6	0.563	103.3
2800	0.600	-131.1	0.584	-138.8	5800	0.577	108.1	0.554	101.4
2850	0.592	-134.2	0.577	-141.4	5850	0.569	106.2	0.547	99.9
2900	0.583	-136.7	0.569	-144.1	5900	0.562	105.1	0.541	98.5
2950	0.576	-139.2	0.562	-146.7	5950	0.556	103.0	0.557	97.1
3000	0.570	-141.7	0.558	-149.2	6000	0.551	102.1	0.553	96.0

Table 1.2. LOX1 Input S_{11} -Parameter

FREQ.	5VDC	5VDC	3.3VDC	3.3VDC		FREQ.	5VDC	5VDC	3.3VDC	3.3VDC
(MHz)	Amplitude	Degree	Amplitude	Degree		(MHz)	Amplitude	Degree	Amplitude	Degree

50	0.648	-30.3	0.648	-30.4	3050	0.155	173.0	0.162	170.5
100	0.460	-33.8	0.459	-39.9	3100	0.157	169.0	0.164	165.7
150	0.382	-32.2	0.381	-32.2	3150	0.159	165.0	0.167	161.5
200	0.343	-30.7	0.342	-30.7	3200	0.162	161.0	0.169	157.7
250	0.318	-29.8	0.318	-29.0	3250	0.165	158.0	0.173	154.4
300	0.301	-29.6	0.300	-29.8	3300	0.168	155.0	0.175	151.6
350	0.287	-30.0	0.287	-30.2	3350	0.171	152.0	0.177	149.5
400	0.276	-30.7	0.276	-30.9	3400	0.173	150.0	0.179	147.7
450	0.266	-30.7	0.267	-32.1	3450	0.173	149.0	0.178	146.1
500	0.260	-33.3	0.261	33.6	3500	0.172	147.0	0.177	144.8
550	0.260	-33.3	0.261	-33.6	3550	0.170	146.0	0.174	143.6
600	0.255	-35.1	0.250	-37.0	3600	0.167	145.0	0.171	142.9
650	0.250	-37.0	0.248	-39.4	3650	0.162	145.0	0.166	142.4
700	0.245	-41.1	0.245	-41.5	3700	0.155	145.0	0.160	142.1
750	0.244	-43.4	0.245	-43.8	3750	0.148	144.0	0.152	141.9
800	0.244	-45.6	0.245	-46.1	3800	0.140	144.0	0.143	141.2
850	0.250	-47.7	0.246	-48.3	3850	0.131	144.0	0.134	141.4
900	0.245	-50.0	0.247	-50.7	3900	0.122	144.0	0.126	140.5
950	0.246	-52.3	0.247	-53.3	3950	0.112	143.0	0.116	139.4
1000	0.246	-54.7	0.246	-55.0	4000	0.102	142.0	0.106	137.9
1050	0.242	-59.1	0.242	-60.5	4050	0.100	142.0	0.104	138.4
1100	0.240	-61.5	0.240	-62.3	4100	0.091	141.0	0.095	137.1
1150	0.238	-63.1	0.238	-63.9	4150	0.083	139.0	0.087	135.1
1200	0.235	-64.7	0.236	-65.5	4200	0.074	138.0	0.079	132.5
1250	0.233	-66.2	0.233	-67.1	4250	0.067	135.0	0.071	129.8
1300	0.230	-68.0	0.230	-68.9	4300	0.060	133.0	0.065	126.7
1350	0.226	-69.7	0.226	-70.5	4350	0.055	129.0	0.060	123.0
1400	0.222	-71.5	0.222	-72.5	4400	0.050	126.0	0.055	119.1
1450	0.218	-73.6	0.218	-74.6	4450	0.046	123.0	0.051	116.3
1500	0.214	-75.9	0.214	-77.0	4500	0.045	123.0	0.050	115.8
1550	0.209	-78.4	0.211	-79.5	4550	0.045	124.0	0.050	117.2
1600	0.205	-81.1	0.207	-82.2	4600	0.047	126.0	0.053	118.8
1650	0.202	-84.0	0.204	-85.2	4650	0.053	128.0	0.058	121.2
1700	0.199	-87.1	0.200	-88.4	4700	0.060	129.0	0.064	122.7
1750	0.197	-90.5	0.199	-91.9	4750	0.068	130.0	0.072	123.9
1800	0.195	-94.0	0.197	-95.4	4800	0.076	130.0	0.064	122.5
1850	0.195	-97.4	0.197	-99.0	4850	0.083	130.0	0.086	125.3
1900	0.195	-97.5	0.197	-102.4	4900	0.091	131.0	0.094	126.4
1950	0.194	-101.0	0.195	-106.6	4950	0.099	132.0	0.102	127.6
2000	0.193	-105.0	0.195	-109.5	5000	0.100	133.0	0.111	128.6
2050	0.196	-110.0	0.199	-111.4	5050	0.122	132.0	0.125	128.0
2100	0.199	-112.0	0.202	-113.7	5100	0.129	132.0	0.131	128.0

2150	0.201	-114.0	0.204	-116.0	5150	0.134	133.0	0.137	129.4
2200	0.202	-116.0	0.206	-128.1	5200	0.139	133.0	0.142	129.2
2250	0.204	-118.0	0.208	-120.0	5250	0.142	133.0	0.144	128.5
2300	0.205	-120.0	0.209	-122.0	5300	0.144	132.0	0.146	127.4
2350	0.205	-122.0	0.209	-123.8	5350	0.144	130.0	0.146	125.5
2400	0.204	-123.0	0.208	-125.1	5400	0.141	127.0	0.142	123.2
2450	0.202	-125.0	0.206	-127.4	5450	0.136	125.0	0.137	120.1
2500	0.200	-127.0	0.204	-129.7	5500	0.129	122.0	0.131	116.5
2550	0.197	-129.0	0.202	-132.4	5550	0.121	1118.0	0.121	112.9
2600	0.193	-132.0	0.198	-135.7	5600	0.110	113.0	0.117	106.4
2650	0.189	-136.0	0.193	-139.6	5650	0.098	106.0	0.100	99.3
2700	0.183	-141.0	0.187	-144.4	5700	0.088	99.0	0.091	190.9
2750	0.175	-146.0	0.179	-149.4	5750	0.079	189.0	0.083	181.1
2800	0.168	-151.0	0.172	-154.6	5800	0.070	78.0	0.076	169.3
2850	0.162	-156.0	0.167	-159.9	5850	0.065	63.0	0.073	155.9
2900	0.157	-161.0	0.163	-165.1	5900	0.063	49.0	0.073	142.0
2950	0.155	-167.0	0.161	-170.9	5950	0.064	33.0	0.075	28.5
3000	0.153	-173.0	0.160	-176.7	6000	0.067	18.0	0.079	16.1

Table 1.3. LOX2 Input S_{11} -Parameter

FREQ. (MHz)	5VDC Amplitude	5VDC Degree	3.3VDC Amplitude	3.3VDC Degree	FREQ. (MHz)	5VDC Amplitude	5VDC Degree	3.3VDC Amplitude	3.3VDC Degree
50	0.756	-18.6	0.775	-19.6	1550	0.304	-92.1	0.306	-93.3
100	0.619	-26.4	0.625	-27.2	1600	0.301	-94.5	0.304	-95.7
150	0.537	-29.1	0.599	-29.7	1650	0.299	-97.1	0.303	-98.4
200	0.488	-30.7	0.489	-31.2	1700	0.299	-99.8	0.302	-101.1
250	0.455	-32.2	0.456	-32.7	1750	0.298	-102.3	0.300	-103.9
300	0.431	-34.1	0.432	-34.5	1800	0.298	-105.4	0.301	-106.7
350	0.411	-35.1	0.413	-36.6	1850	0.299	-108.1	0.301	-109.5
400	0.395	-38.4	0.397	-38.8	1900	0.299	-110.8	0.303	-112.2
450	0.382	-40.8	0.382	-41.3	1950	0.302	-113.4	0.305	-114.7
500	0.370	-43.4	0.372	-43.9	2000	0.303	-115.9	0.307	-117.4
550	0.362	-46.1	0.362	-46.6	2050	0.310	-117.1	0.314	-118.6
600	0.354	-48.8	0.355	-49.4	2100	0.315	-119.2	0.319	-120.7
650	0.348	-51.6	0.349	-52.2	2150	0.305	-115.0	0.324	-122.7
700	0.344	-54.3	0.345	-55.9	2200	0.324	-123.0	0.329	-124.6
750	0.341	-57.1	0.342	-57.9	2250	0.327	-124.8	0.332	-126.4
800	0.338	-59.9	0.340	-60.5	2300	0.330	-126.5	0.335	-128.2
850	0.337	-62.4	0.337	-632.0	2350	0.334	-128.1	0.327	-129.9
900	0.335	-65.0	0.336	-65.7	2400	0.335	-129.7	0.339	-131.4
950	0.332	-67.3	0.334	-68.0	2450	0.335	-131.4	0.337	-133.2
1000	0.331	-69.4	0.332	-70.2	2500	0.333	-133.1	0.336	-137.9
1050	0.326	-72.1	0.327	-73.4	2550	0.330	-134.7	0.333	-136.7

1100	0.325	-74.6	0.325	-75.6	2600	0.325	-136.8	0.330	-138.7
1150	0.323	-76.3	0.325	-77.1	2650	0.319	-138.8	0.323	-140.8
1200	0.322	-78.1	0.323	-78.9	2700	0.312	-140.7	0.316	-142.9
1250	0.319	-79.8	0.321	-80.7	2750	0.305	-142.6	0.309	-144.9
1300	0.316	-81.5	0.318	-82.5	2800	0.299	-144.7	0.303	-146.0
1350	0.327	-71.1	0.315	-84.4	2850	0.295	-146.9	0.298	-147.1
1400	0.312	-85.4	0.313	-83.4	2900	0.291	-149.1	0.293	-151.4
1450	0.308	-87.4	0.311	-88.5	2950	0.287	-151.4	0.289	-153.7
1500	0.306	-89.7	0.309	-90.9	3000	0.285	-153.6	0.287	-156.0

Table 1.4. Up converter output S_{22} -Parameter

FREQ.	5VDC	5VDC	3.3VDC	3.3VDC		FREQ.	5VDC	5VDC	3.3VDC	3.3VDC
(MHz)	Amplitude	Degree	Amplitude	Degree		(MHz)	Amplitude	Degree	Amplitude	Degree
50	0.883	-6.1	0.912	-6.9		3050	0.739	129.7	0.738	129.6
100	0.962	-11.1	0.883	-11.5		3100	0.729	126.8	0.729	126.8
150	0.838	-14.6	0.857	-14.7		3150	0.710	124.5	0.711	124.7
200	0.827	-16.5	0.845	-16.5		3200	0.686	122.6	0.687	122.8
250	0.841	-17.6	0.859	-18.3		3250	0.654	120.8	0.657	121.1
300	0.854	-20.3	0.871	-21.1		3300	0.620	119.0	0.625	119.4
350	0.863	-23.0	0.878	-24.2		3350	0.589	116.8	0.595	117.4
400	0.863	-26.4	0.877	-27.3		3400	0.564	114.6	0.570	115.0
450	0.858	-29.7	0.872	-30.7		3450	0.543	111.7	0.551	112.2
500	0.851	-33.3	0.864	-34.3		3500	0.532	108.6	0.541	109.1
550	0.841	-37.6	0.853	-38.7		3550	0.530	105.6	0.541	106.2
600	0.827	-42.4	0.840	-43.6		3600	0.539	103.6	0.550	103.8
650	0.812	-47.8	0.825	-49.1		3650	0.558	101.0	0.570	101.8
700	0.793	-53.7	0.807	-55.2		3700	0.583	99.9	0.597	100.5
750	0.774	-59.7	0.787	-61.6		3750	0.613	99.4	0.628	99.9
800	0.756	-65.6	0.762	-67.7		3800	0.644	99.4	0.660	99.8
850	0.739	-71.0	0.737	-73.1		3850	0.672	99.7	0.690	99.9
900	0.723	-75.7	0.714	-77.1		3900	0.694	100.4	0.713	100.2
950	0.709	-79.1	0.700	-79.9		3950	0.707	100.1	0.726	100.3
1000	0.712	-83.3	0.715	-83.7		4000	0.706	100.5	0.725	100.3
1050	0.715	-87.0	0.711	-87.6		4050	0.690	103.2	0.709	102.8
1100	0.718	-89.3	0.717	-89.4		4100	0.667	102.9	0.686	102.3
1150	0.723	-91.1	0.723	-91.0		4150	0.635	101.9	0.623	101.2
1200	0.725	-93.0	0.727	-93.2		4200	0.599	100.1	0.615	99.3
1250	0.723	-95.4	0.726	-95.6		4250	0.563	97.3	0.578	96.2
1300	0.715	-98.1	0.720	-98.3		4300	0.531	93.2	0.547	92.0
1350	0.702	-101.0	0.708	-101.0		4350	0.512	87.8	0.527	86.7
1400	0.684	-104.6	0.691	-104.0		4400	0.505	81.7	0.521	80.6
1450	0.661	-108.6	0.669	-109.0		4450	0.511	75.7	0.527	74.7
1500	0.633	-112.8	0.642	-113.0		4500	0.532	70.8	0.547	69.8

1550	0.692	-116.9	0.621	-117.3	4550	0.562	57.3	0.576	86.4
1600	0.594	-121.7	0.609	-122.2	4600	0.594	65.3	0.609	64.4
1650	0.577	-126.5	0.589	-127.0	4650	0.627	64.4	0.641	63.6
1700	0.569	-130.9	0.581	-131.6	4700	0.656	64.7	0.669	63.9
1750	0.567	-135.5	0.581	-136.1	4750	0.677	66.0	0.689	65.2
1800	0.571	-140.1	0.585	-140.7	4800	0.694	67.7	0.705	67.0
1850	0.580	-144.0	0.595	-144.9	4850	0.703	69.8	0.711	69.0
1900	0.592	-148.2	0.607	-148.9	4900	0.706	71.9	0.715	71.1
1950	0.608	-151.0	0.623	-152.6	4950	0.702	73.6	0.710	72.8
2000	0.624	-155.0	0.639	-156.9	5000	0.691	75.0	0.699	74.2
2050	0.651	-156.0	0.667	-157.7	5050	0.697	77.1	0.705	76.3
2100	0.674	-166.5	0.689	-151.3	5100	0.694	76.8	0.702	75.7
2150	0.689	-163.5	0.704	-167.7	5150	0.684	74.5	0.692	73.6
2200	0.704	-166.7	0.717	-167.8	5200	0.665	70.8	0.673	69.7
2250	0.711	-170.3	0.723	-171.5	5250	0.644	65.9	0.651	64.7
2300	0.703	-174.0	0.714	-175.2	5300	0.624	60.2	0.631	59.0
2350	0.687	-177.0	0.695	-178.4	5350	0.607	54.3	0.613	53.9
2400	0.669	-179.9	0.677	178.6	5400	0.592	48.9	0.598	47.5
2450	0.647	176.0	0.652	175.3	5450	0.581	44.5	0.585	43.3
2500	0.622	173.6	0.627	172.3	5500	0.573	41.7	0.578	40.5
2550	0.604	170.5	0.609	169.2	5550	0.569	40.3	0.574	39.1
2600	0.592	166.9	0.597	165.6	5600	0.567	39.7	0.570	38.6
2650	0.589	163.0	0.593	161.7	5650	0.565	40.1	0.569	39.1
2700	0.594	158.8	0.590	157.7	5700	0.565	41.2	0.568	40.2
2750	0.609	154.4	0.612	153.4	5750	0.566	42.6	0.569	41.7
2800	0.631	149.9	0.634	149.0	5800	0.570	43.7	0.572	42.9
2850	0.656	145.3	0.658	144.6	5850	0.576	45.1	0.580	44.3
2900	0.682	141.4	0.683	140.8	5900	0.583	46.0	0.586	45.5
2950	0.709	137.6	0.710	137.2	5950	0.597	47.0	0.595	46.3
3000	0.729	133.9	0.728	133.6	6000	0.605	47.4	0.609	46.7

Linearity and Dynamic Range

The Gilbert cell structure does not yield a mixer with a high dynamic range. The following two equations describe linear dynamic range and spurious free dynamic range:

$$\text{Linear dynamic range} = P_{1\text{dB}} - [\text{NF} + G + 3\text{dB} - 114 \text{ dBm} + 10 \log_{10}(\text{BW})]$$

$$\text{Spurious free dynamic range} = 2/3 [\text{IP}_3 - G - \text{NF} - 10 \log_{10}(\text{BW}) + 114 \text{ dBm}]$$

where $P_{1\text{dB}}$ is the output power of the mixer at 1dB gain compression (in dBm), NF is the noise figure of the mixer (in dB), G is the conversion gain of the mixer (in dB), BW is the bandwidth of the mixer (in dB), and IP_3 is the output third-order interception point (in dB). These equations show that dynamic range is a function of noise figure, output compression point, interception point, and gain. Because the MAX2683 has moderate dB conversion gain, its dynamic range is not very low. The linearity of the MAX2683 is externally programmable with a single resistor. Increasing or decreasing that bias-resistor value will change the linearity performance of

the MAX2683. There is a trade-off between linearity and supply current when the value of the bias resistor is changed.

Typical Application

Figure 3 shows a typical upconverter application circuit. As depicted in the figure, the mixer is a multiplier based on the Gilbert cell with an RF input amplifier. Double-balanced mixers such as this offer good port-to-port isolation and low LO free through at the output. RF output port input is configured for differential operation. However, the RF input and LO input can be driven in a single-ended operation. The LO and RF input are 50Ω . The mixer output requires an external matching network to convert high output impedance into lower impedance to meet system requirements. A balun or impedance matching transformer is required for such impedance transform and differential to single-ended transform. The test data of that application circuit is shown in Table 2.

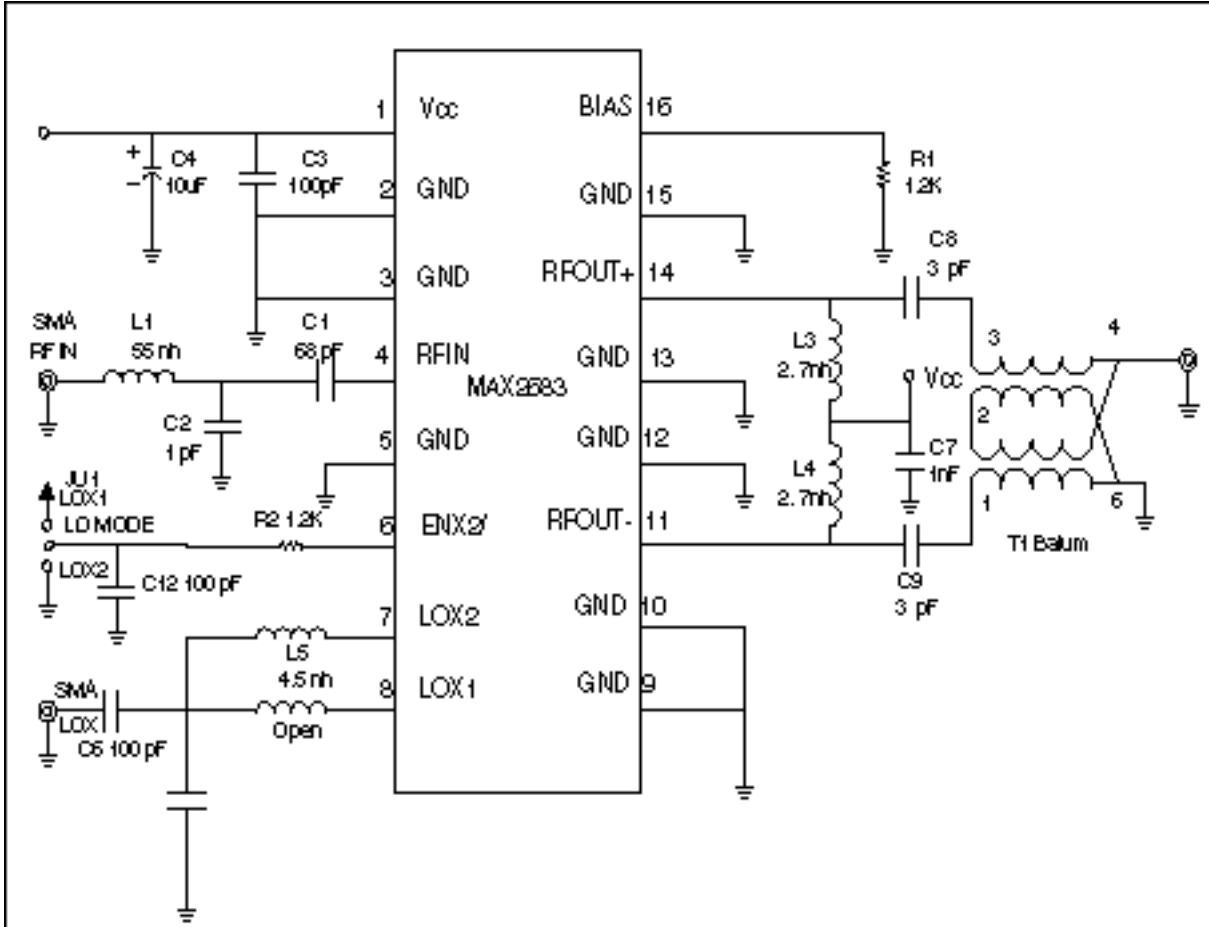

Figure 3. Application Schematic of the MAX2683.

Table 2. Test Data of a MAX2683 Application

(Test conditions: $V_{CC} = +5.0V$, $R_{BIAS} = 1.2k\Omega$, $/ENX2\backslash = GND$, $f_{RFIN} = 350MHz$, $P_{RFIN} = -20dBm$, $f_{LO} = 1600MHz$, $P_{LO} = -5dBm$; all input/output ports terminated in 50Ω ; $RFOUT+$ and $RFOUT-$ matched to single-ended 50Ω load; $T_A = +25^\circ C$, unless otherwise noted.)

PARAMETER	CONDITIONS		TESTED	UNITS
Input Frequency Range	Note 1		350	MHz
RF Output Frequency Range	Note 1		3.55	GHz
LOX2 Frequency Range			1.6	GHz
LOX1 Frequency Range			N/A	GHz
Conversion Gain	$f_{LOX2} = 1600MHz$, $f_{RFOUT} = 3.55GHz$, $V_{CC} = +5V$		8.6	dB
Gain Variation over Temperature	$T_A = -40^\circ C$ to $+85^\circ C$, $V_{CC} = +5V$		TBD	dB
Input 1dB Compression Point	$f_{LOX2} = 1600MHz$, $f_{RFOUT} = 3.55GHz$, $V_{CC} = +5V$		-6	dBm
Input Third-Order Intercept Point	$f_{LOX2} = 1600MHz$, $f_{RFOUT} = 3.55GHz$, $V_{CC} = +5V$, Note 2		+1.3	dBm
Input Second-Order Intercept Point	$f_{LOX2} = 1600MHz$, $f_{RFOUT} = 3.55GHz$, $V_{CC} = +5V$		+42.6	dBm
Noise Figure			TBD	dB
RFIN Input Return Loss	At 350 MHz		<-20	dB
LOX2 Leakage at RFIN	$/ENX2\backslash = GND$	$f_{RFIN} = 1 \times f_{LO}$	-42	dBm
		$f_{RFIN} = 2 \times f_{LO}$	-38	
		$f_{RFIN} = 3 \times f_{LO}$	-49	
LOX1 Leakage at RFIN	$/ENX2\backslash = V_{CC}$	$f_{RFOUT} = 1 \times f_{LO}$	N/A	dBm
LOX2 Leakage at IFOUT+, RFOUT-	$/ENX2\backslash = GND$	$f_{RFOUT} = 1 \times f_{LO}$	-32.7	dBm
		$f_{RFOUT} = 2 \times f_{LO}$	-16.4	
		$f_{RFOUT} = 3 \times f_{LO}$	-53.1	
LOX1 Leakage at IFOUT+, RFOUT-	$/ENX2\backslash = V_{CC}$	$f_{RFOUT} = 1 \times f_{LO}$	-39	dBm
LOX1, LOX2 Input Return Loss			-18	dB

Notes

Note 1. The device has been fully characterized at this specified frequency range. Operation outside this range is possible but not guaranteed.

Note 2. IIP3 is measured with two tones at 350MHz and 351MHz, -20dBm per tone, $f_{RFLO} = 1.6GHz$.

Note 3. IIP2 is measured with $f_{RFIIN} = 350MHz$, $P_{RFIN} = -20dBm$, $f_{LO} = 1.6GHz$.

Note 4. The input match is optimized for best return loss at $f_{RFIIN} = 350MHz$.

More Information

For technical questions and support: <http://www.maxim-ic.com/support>

For samples: <http://www.maxim-ic.com/samples>

Other questions and comments: <http://www.maxim-ic.com/contact>

Related Parts

MAX2683: [QuickView](#) -- [Full \(PDF\) Data Sheet](#)

AN286, AN 286, APP286, Appnote286, Appnote 286

Copyright © by Maxim Integrated Products

Additional legal notices: <http://www.maxim-ic.com/legal>