

APPLICATION NOTE 2857

T1/E1/J1, N+1 Redundancy With Analog Switches

Modern communications systems with multi-port T1/E1/J1 line cards employ redundancy to achieve the high-availability telecom networks require. Traditionally, these systems have used relays to implement N+1 redundancy switching. As the number of T1/E1/J1 ports per line card and the number of line cards per system increases, relays become impractical because of the board space and power they require. Designers are using analog switches to replace relays. The advantages of analog switches over relays include those listed in Table 1.

Related Application Note: [Intel\(R\) T1/E1/J1, N+1 Redundancy With Analog Switches and Intel\(R\) LXT38x Line Interface Units](#)

Table 1. Analog Switches vs. Relays

	Relay	Analog Switch
Board Space	100mm ²	15mm ²
Power Consumption	140mW	5μW
Switching Speed	4ms	30ns
Reliability	Mechanical Operation	No Moving Parts

This application note shows how to implement T1/E1/J1, N+1 redundancy protection using analog switches. It provides guidelines for selecting analog switches for your application and shows test results using Maxim/Dallas analog switches and T1/E1/J1 transceivers.

Redundancy Architectures

Figures 1 and 2 show two redundancy architectures with analog switches. For clarity, there are separate drawings for the transmit and receive interfaces. Receive and transmit interfaces will reside in the same board for each T1/E1 port. The drawings represent the typical interface transformers and resistors recommended for a Dallas/Maxim transceiver such as the DS2155. In both cases, there is a protection bus running in the backplane where the input or output signals can be routed through the analog switches. The protection bus connects directly to a backup (protection) line card.

In Figure 1 ("Architecture A"), analog switches reside in the line cards themselves. Architecture A has the advantage of not requiring a separate line card for protection switching as in the "Architecture B" below. It does require that the switches be powered even through fail-over switching which could require a separate, dedicated power supply.

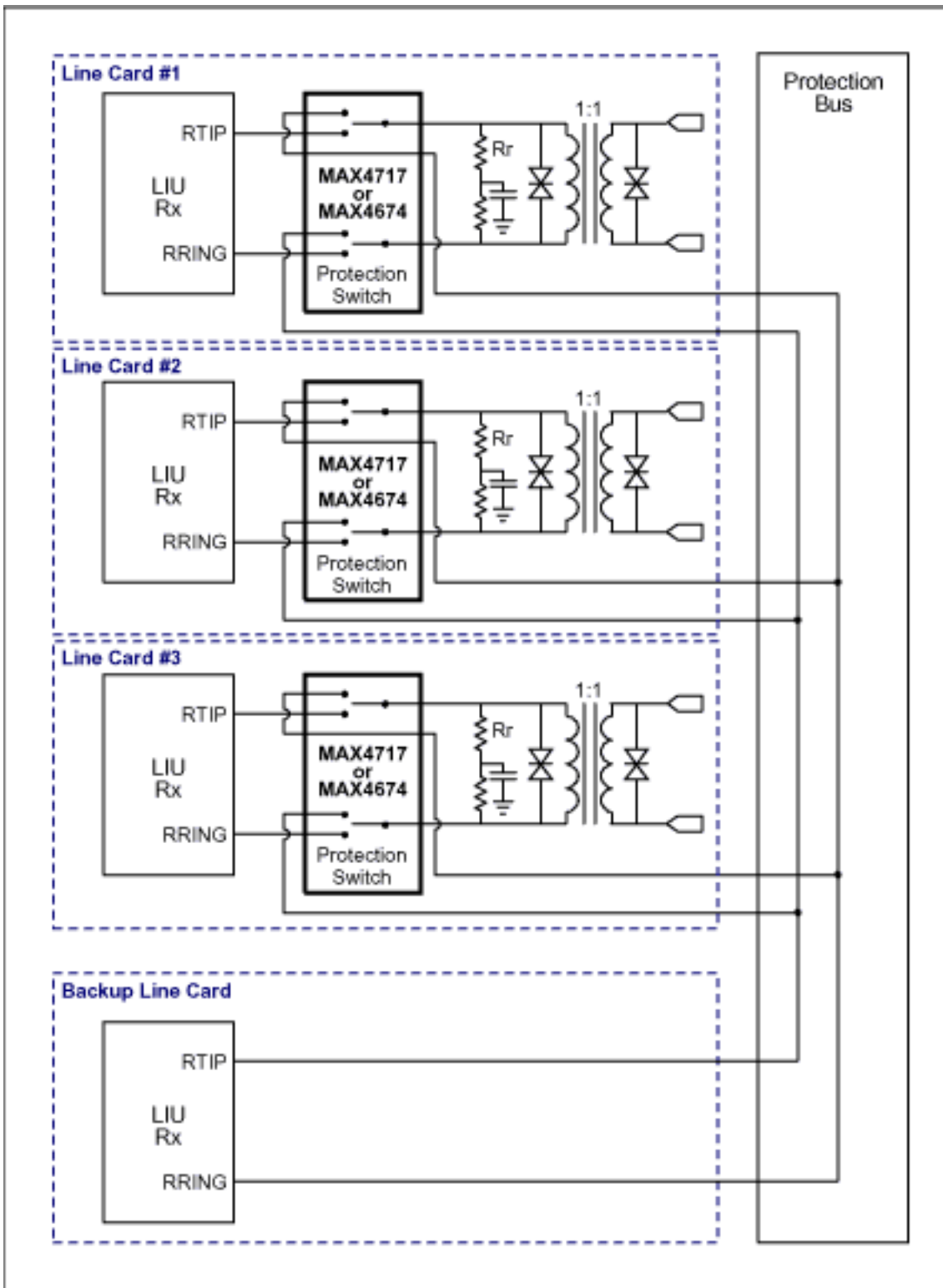

Figure 1a. Redundancy Architecture A: Receive Path.

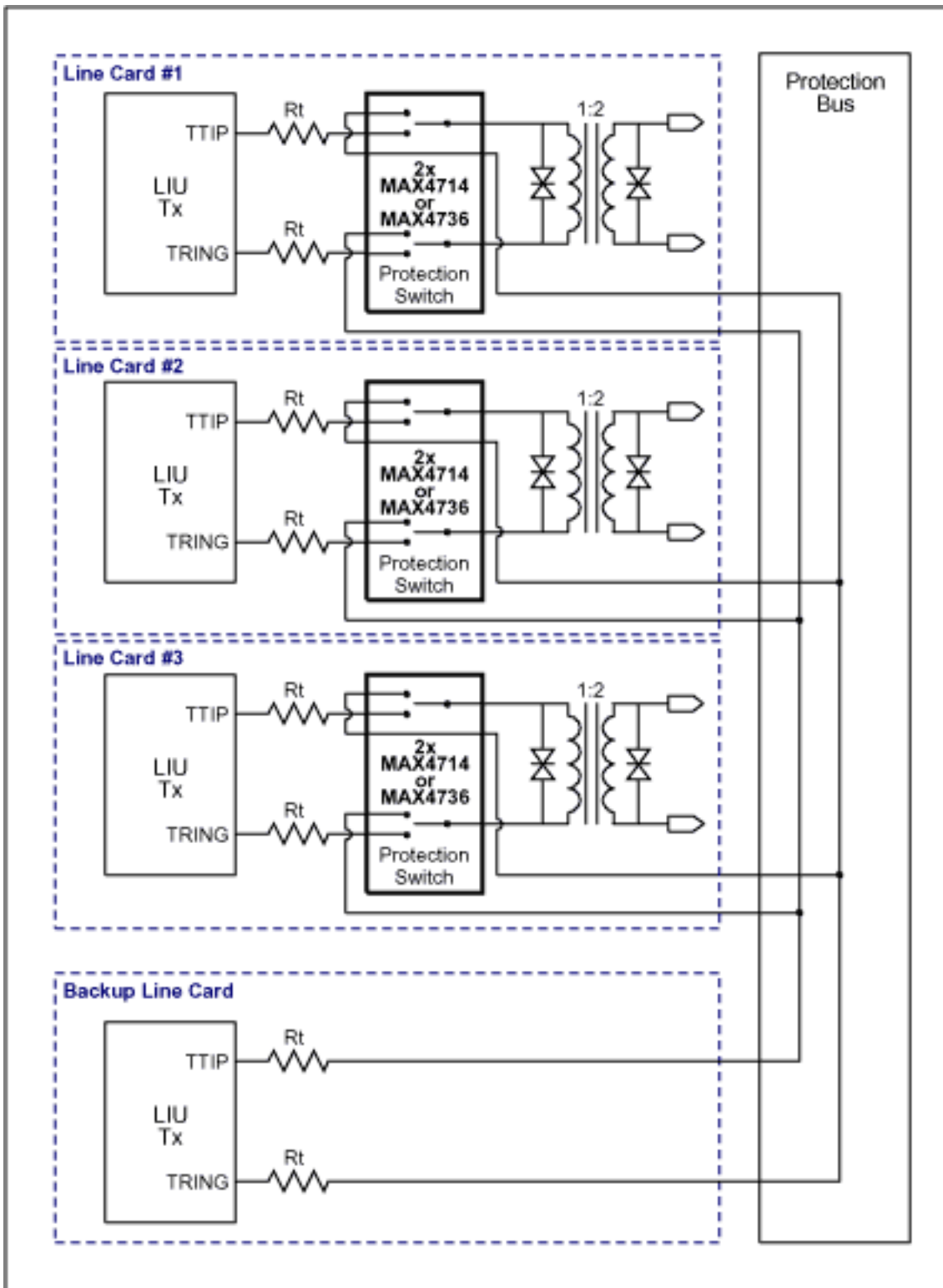

Figure 1b. Redundancy Architecture A: Transmit Path.

In Figure 2 ("Architecture B"), analog switches reside in a separate "Protection Switching Card". Architecture B has the advantage that it does not rely on the power being always "on" in the line cards themselves but it does require an extra protection switching card.

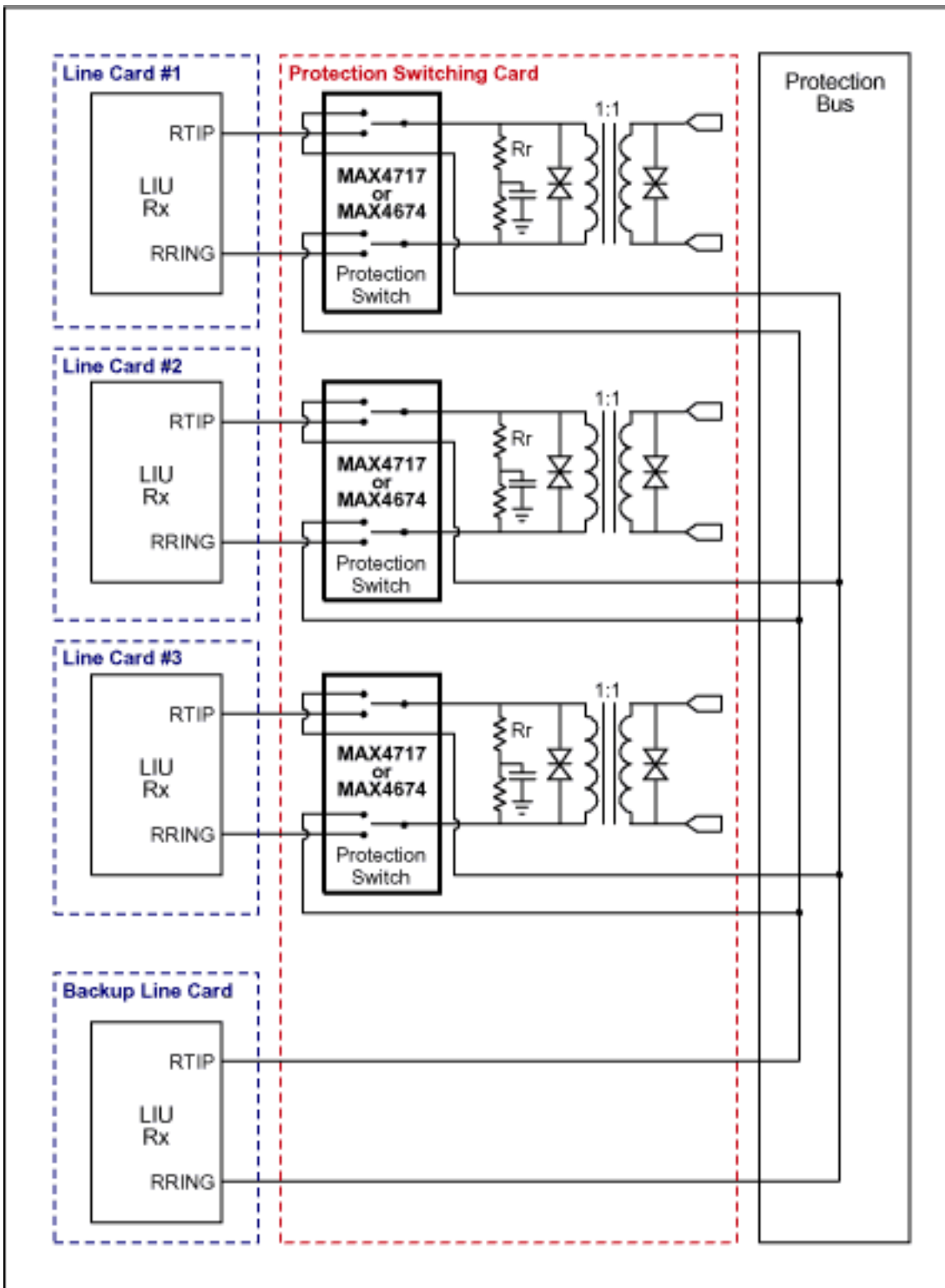

Figure 2a. Redundancy Architecture B: Receive Path.

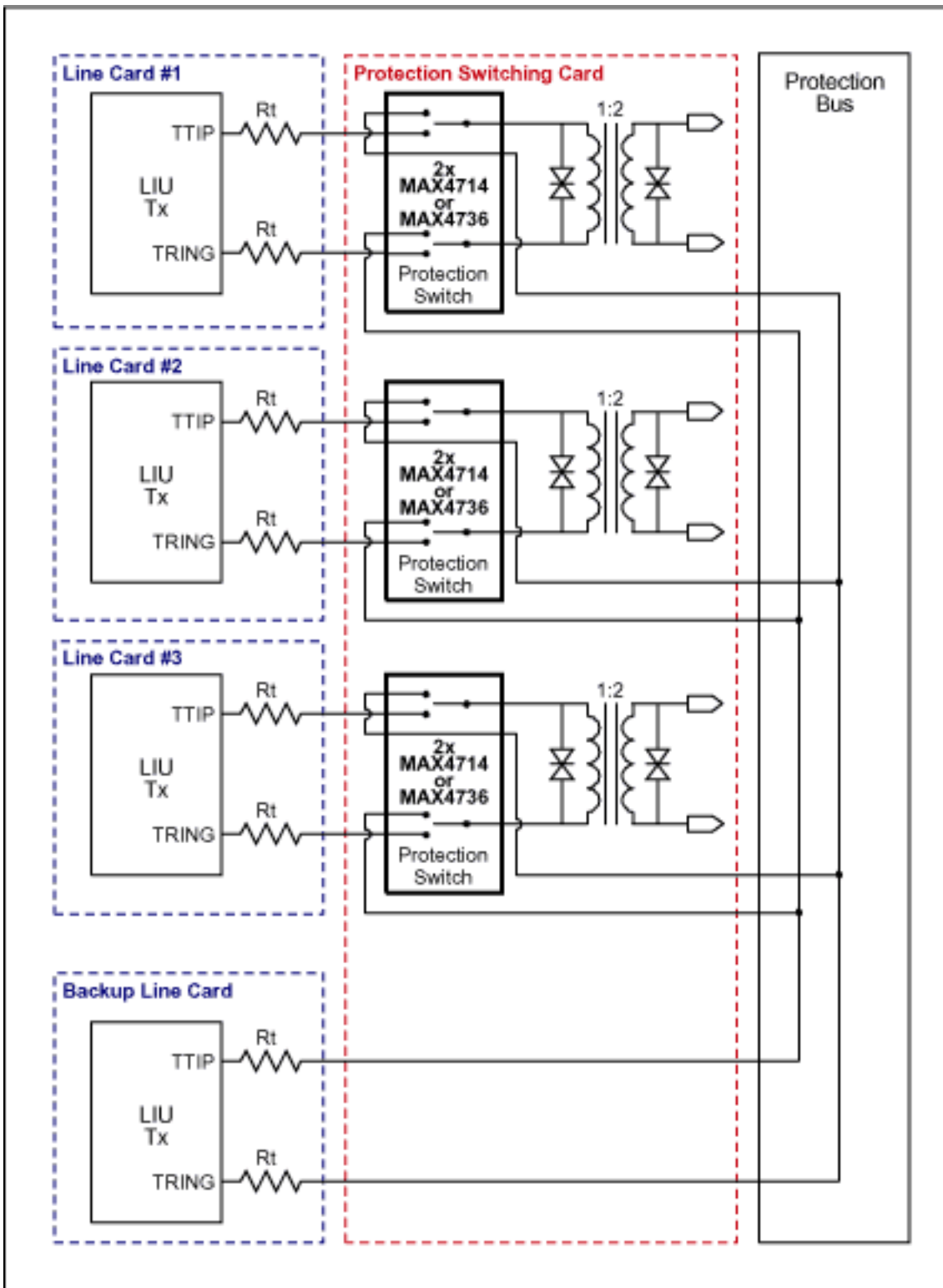

Figure 2b. Redundancy Architecture B: Transmit Path.

Analog Switch Selection

In order to meet the T1/E1/J1 interface specifications, the analog switches must be carefully selected for their electrical characteristics. Since the requirements for transmit and receive interfaces are quite different, we will examine them separately.

Transmit Interface Switch

In the transmit interface, the switch on resistance (R_{on}) is a critical parameter. In Figures 1 and 2 we can see that the switch R_{on} is in series with the output driver and the transformer primary and therefore, can cause a slight reduction in the output pulse amplitude. In most cases, the amplitude reduction can be compensated by simply reducing the series resistors (R_t) by an amount corresponding to the switch typical R_{on} value. As an example, if the transceiver recommended R_t is $11\ \Omega$ and R_{on} (typ.) is $0.5\ \Omega$ then the actual R_t value should be $10.5\ \Omega$. Keeping R_{on} low relative to the R_t resistors is important to ensure proper operation over the complete operating range including temperature and power supply variations. Low R_{on} also results in better R_{on} flatness and therefore reduces distortion of the output pulse.

Some transceivers (such as the DS2155) also allow you to adjust the output pulse amplitude in software. This can be very useful to ensure proper pulse template margin in transceivers where no output resistors are required ($R_t = 0$).

Another important parameter in the transmit interface is the on and off capacitance of the switch (C_{ON} and C_{OFF}). Excessive on capacitance can distort the output pulse and reduce the transmit return loss performance. The off capacitance is important when the backup line card transmits through the protection bus as shown in Figures 1 and 2. In this situation, the output driver sees the parallel combination of all the off capacitance from the other line cards.

Analog switches such as the MAX4714 and MAX4736 offer excellent characteristics for T1/E1 transmit switching applications. They combine very low R_{on} ($0.6\ \Omega$ typ.) with low capacitance ($C_{ON} = 65\text{pF}$ typ. and $C_{OFF} = 30\text{pF}$ typ).

Receive Interface Switch

In the receive path, one of the main considerations is how the switch affects the line termination and consequently the receive return loss performance. Receive return loss is directly tied to how well the input termination matches the nominal line impedance over the relevant frequency range. In T1/E1/J1 applications, this range extends up to 3 MHz. Therefore, it is important to keep capacitance low so that the performance at high frequencies is kept within standards such as ITU-T G.703. Another advantage of low capacitance is that it helps improve the switch off-isolation. Off-isolation is especially important in the receive interface to avoid noise coupling and bit errors.

The switch R_{on} resistance will be in series with the receiver pins (RTIP/RRING) as represented in Figures 1 and 2. If the line termination is provided exclusively by the external resistors R_r , then R_{on} will not impact the receive circuit significantly as the receiver impedance is very high. However, some modern transceivers such as the Dallas DS2155 provide internal termination by connecting a software-selectable resistor in parallel with the external resistors R_r ($60\ \Omega$ each). Therefore R_{on} in the receive interface can be made higher than in the transmit interface (to minimize capacitance) but it should still be small enough not to affect performance with internally terminated transceivers.

The Maxim MAX4717 offers the right balance of R_{on} and low capacitance for T1/E1/J1 receive interface applications. It offers $3\ \Omega$ typ. R_{on} , and very low capacitance ($C_{ON} = 15\text{pF}$ typ. and $C_{OFF} = 9\text{pF}$ typ).

Implementation with Dallas/Maxim DS2155

The circuits in Figures 1 and 2 were tested using the Dallas DS2155 Single-Chip-Transceiver evaluation board. The analog switches were powered with a 3.3V power supply. The following component values were used in this test setup:

Component	Value T1 Mode	Value E1 Mode (Twisted Pair)	Value E1 Mode (Coaxial Cable)	Notes
Transmit Transformer	1:2 PE-65771	1:2 PE-65771	1:2 PE-65771	Can also use other Dallas/Maxim recommended transformers (See App Note 351: "Transformer Selection Guide")
Receive Transformer	1:1 PE-68644	1:1 PE-68644	1:1 PE-68644	
Rt	0 Ω	10 Ω	10 Ω	Internal transmit termination off
Rr	60 Ω	60 Ω	60 Ω	Internal receive termination on
Cr	0.1 μ F	0.1 μ F	0.1 μ F	
Receive Switch	MAX4717			
Transmit Switch	MAX4714			

The internal transmit termination feature must be disabled when using this circuit. In order to use the same transmit resistors for E1 twisted-pair and coaxial cable, you must write the following value to the Transmit Line Build Out Control Register (TLBC):

TLBC (Address 7Dh) = 6Ah

This sets the driver voltage such that the output pulse has the right amplitude for both 120 Ω (twisted pair) and 75 Ω (coaxial) loads.

Depending on the actual application, you will need to add surge protection devices to the circuit in Figures 1 and 2. Please refer to the Dallas/Maxim website for detailed application notes covering surge protection.

Test Results

Referring to Figures 1 and 2, we can see that as the number of boards N in a N+1 redundancy implementation increases so does the maximum parallel off-capacitance that the backup board transceiver will observe. This parallel capacitance will have some effect on the output pulse shape and in the return loss performance. On the other hand, in normal operation (backup board inactive), the switch on-capacitance is the predominant capacitance the transceiver will see and this (smaller) capacitance is easily handled.

For good performance with the worst case capacitive loading condition (backup board active) it is recommended that the number N does not exceed 8 (1:8 redundancy protection). **Figures 3** through **5** show the measured T1/E1 output pulses.

Figure 3. Output Pulses, T1 Mode

T1, 0-133ft LBO, 0 ft cable, Normal Operation ⁽¹⁾	T1, 0-133ft LBO, 0 ft cable, N = 8 ⁽²⁾
--	---

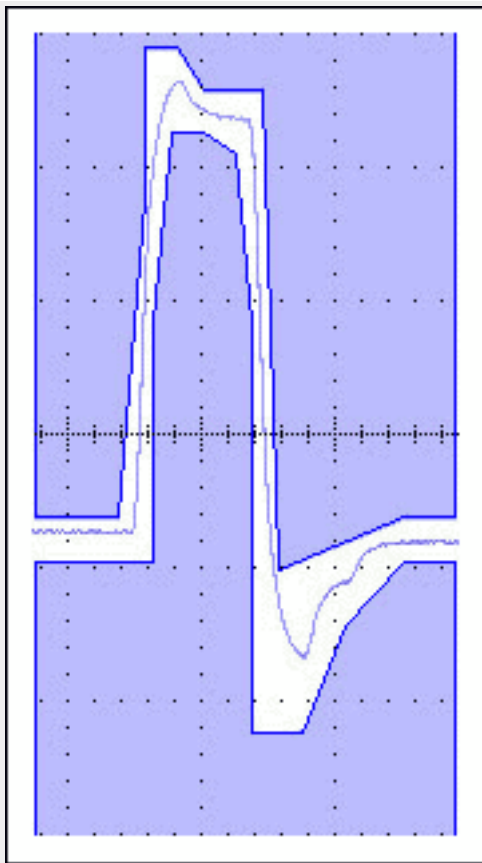

(1) Output pulse through two series switches in the transmit path.

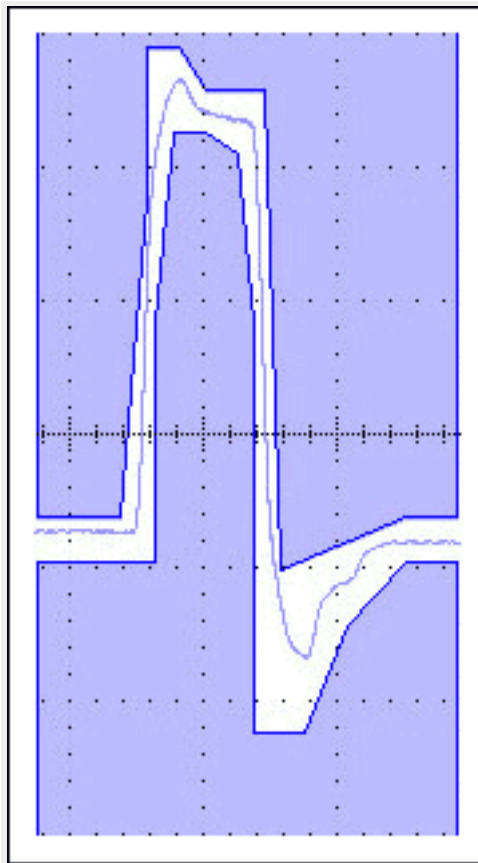

(2) Output pulse from backup board with 8+1 configuration.

Figure 4. Output Pulses, E1 Twisted Pair Cable

E1, Coaxial Cable, Normal Operation (1)

E1, Coaxial Cable, N = 8 (2)

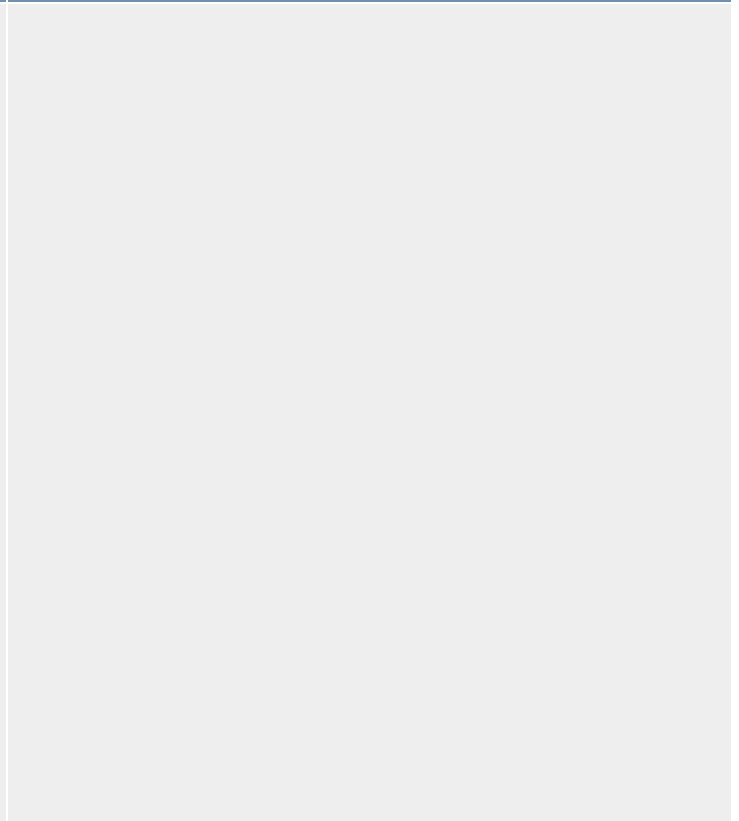
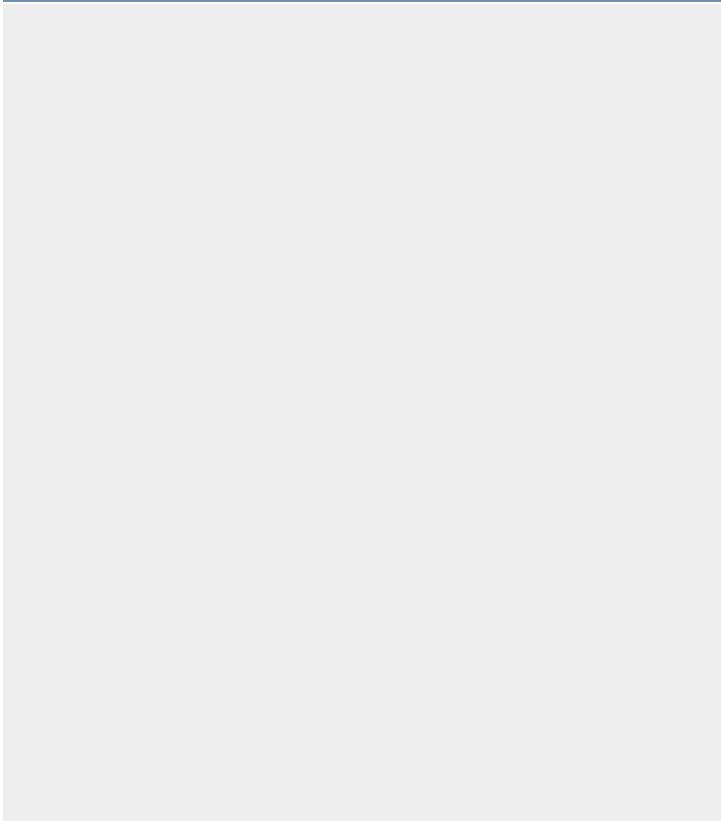

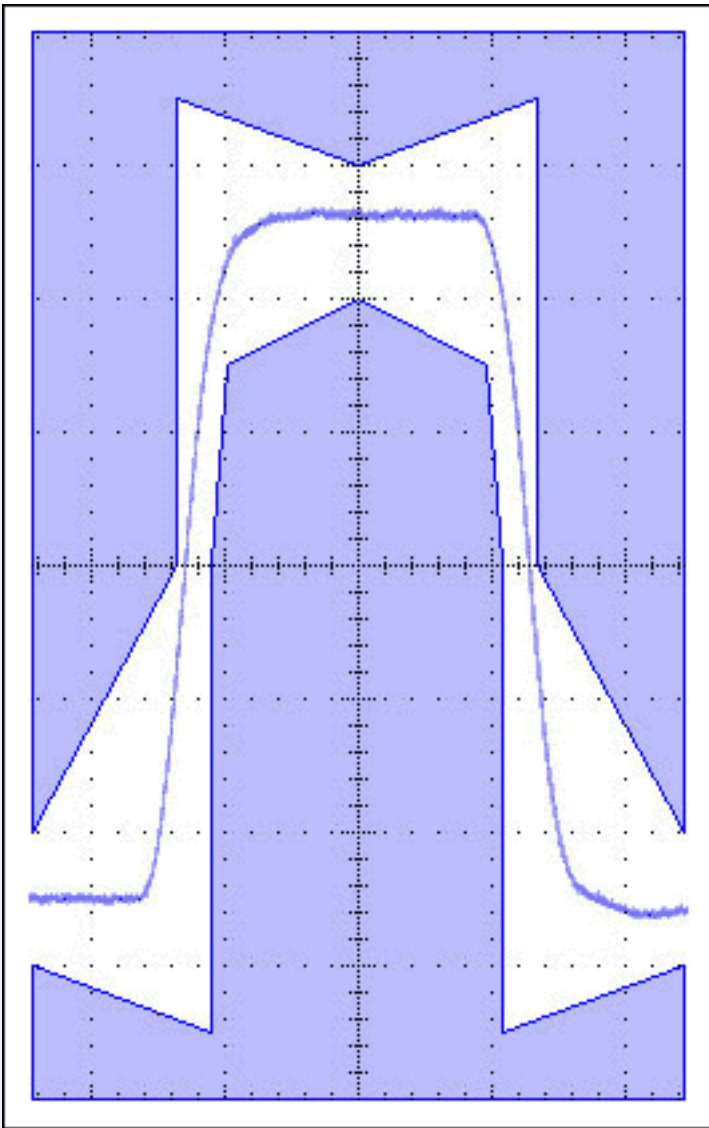

(1) Output pulse through two series switches in the transmit path.

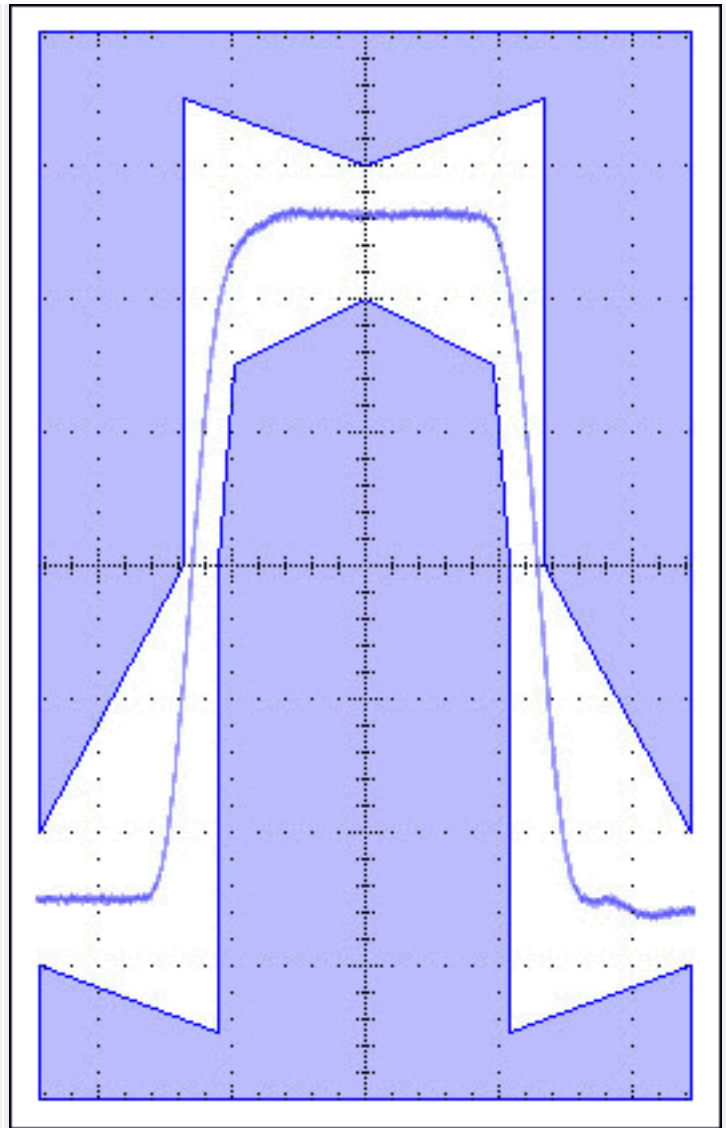

(2) Output pulse from backup board with 8+1 configuration.

Figure 5. Output Pulses, E1 Coaxial Cable

E1, Twisted Pair Cable, Normal Operation (1)

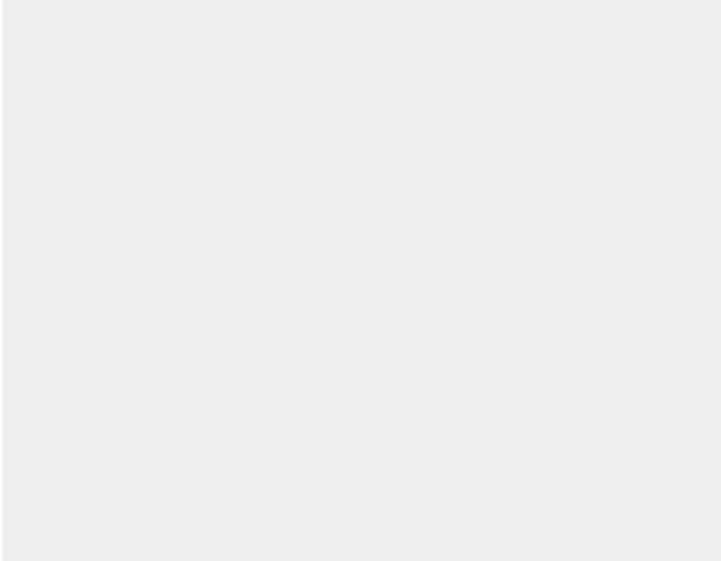

E1, Twisted Pair Cable, N = 8 (2)

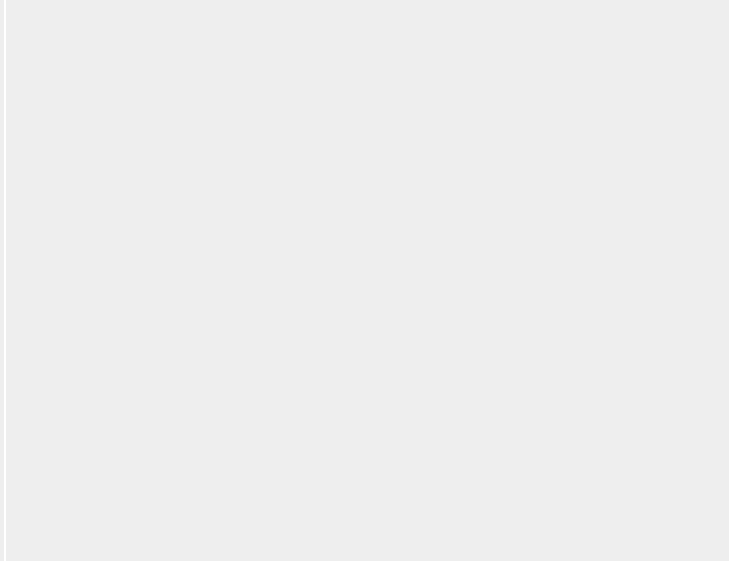

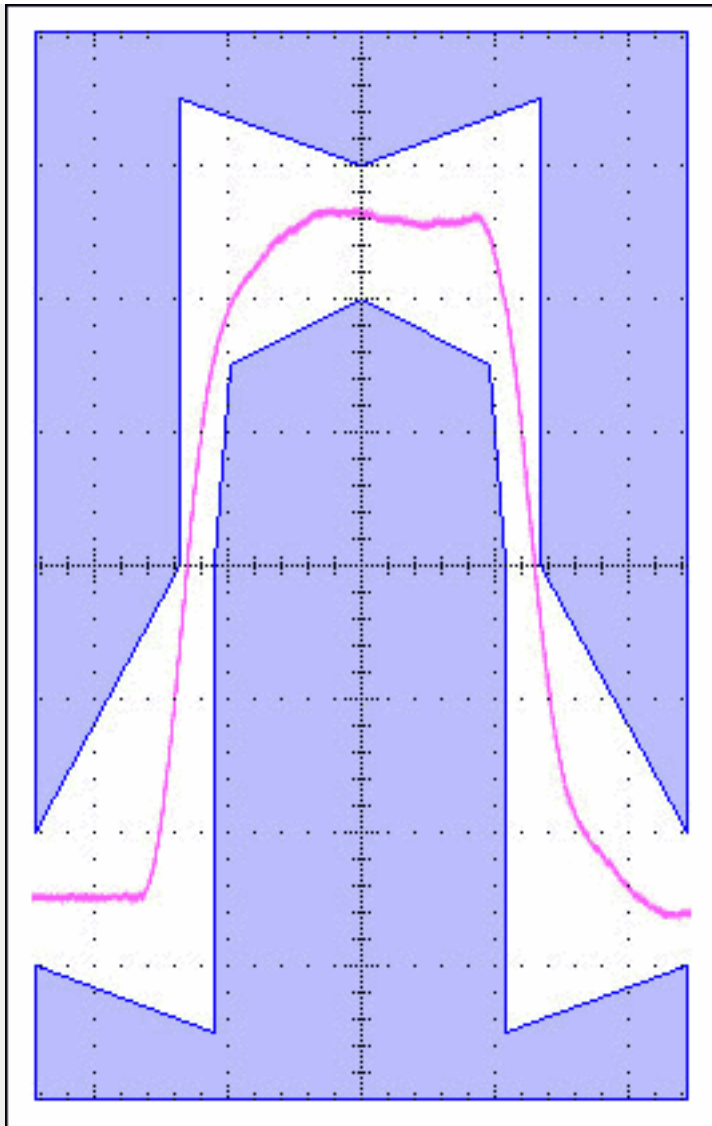

(1) Output pulse through two series switches in the transmit path.

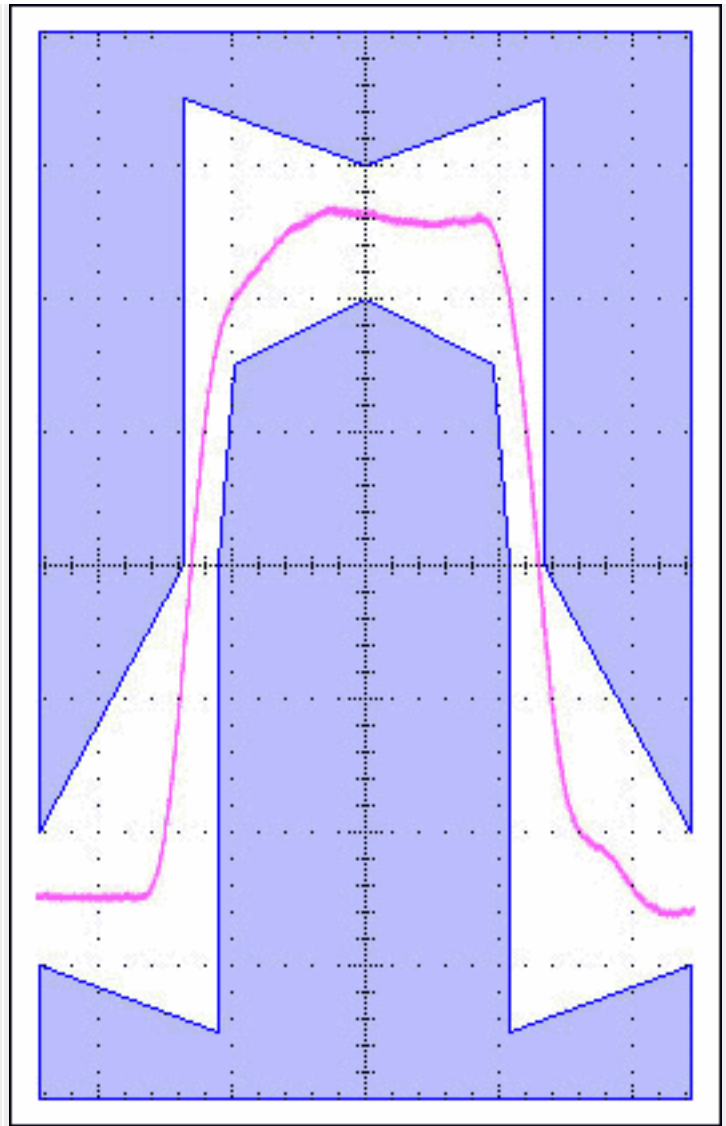

(2) Output pulse from backup board with 8+1 configuration.

Application Note 2857: <http://www.maxim-ic.com/an2857>

More Information

For technical questions and support: <http://www.maxim-ic.com/support>

For samples: <http://www.maxim-ic.com/samples>

Other questions and comments: <http://www.maxim-ic.com/contact>

Related Parts

DS2155: [QuickView](#) -- [Full \(PDF\) Data Sheet](#) -- [Free Samples](#)

MAX4674: [QuickView](#) -- [Full \(PDF\) Data Sheet](#) -- [Free Samples](#)

MAX4714: [QuickView](#) -- [Full \(PDF\) Data Sheet](#)

MAX4717: [QuickView](#) -- [Full \(PDF\) Data Sheet](#) -- [Free Samples](#)

MAX4736: [QuickView](#) -- [Full \(PDF\) Data Sheet](#) -- [Free Samples](#)

AN2857, AN 2857, APP2857, Appnote2857, Appnote 2857

Copyright © 2005 by Maxim Integrated Products

Additional legal notices: <http://www.maxim-ic.com/legal>

