



APPLICATION NOTE 2852

Using a PC to Experiment with the MAX7300/MAX7301 Port Expanders

Abstract: This application note describes a PC program, downloadable for free, to assist in the evaluation of the MAX7300 and MAX7301 GPIO (port expanders).

The MAX7300 and MAX7301 are versatile 28-port, general-purpose input/output (GPIO) processor peripherals. Control is through a high-speed SPI™ (MAX7301) or I²C (MAX7300) serial interface. This application note describes a utility program which allows a MAX7301 or MAX7300 driver to be controlled by a PC. The utility can be used as a stand-alone simply to help an engineer become familiar with the registers and functions of the drivers. Moreover, it can be used to 'prove' an application board prototype by directly controlling the MAX7301 or MAX7300 registers before the equipment's software is complete.

Requirements

A PC running Windows® 95, 98, 98SE, ME, NT, 2000, or XP with a parallel printer port configured for either LPT1 or LPT2.

Description

The utility is a Visual Basic 5 program called MAX7300.EXE which requires the standard Visual Basic run time library MSVBVM50.DLL in order to run at all. The program uses the DriverLINX™ freeware parallel port driver DLPortIO.DLL which provides the Win32 DLL hardware I/O functions not available as standard in Visual Basic. Windows NT and 2000 users also require the DLPortIO.SYS kernel mode driver. Both of these drivers are copyright Scientific Software Tools, Inc. (www.driverlinx.com). DriverLINX is a registered trademark of Scientific Software Tools, Inc.

Installation

To install to a Windows 95, 98, 98SE, ME platform, [download the MAX7300-01.EXE file](#) (812kB). This is a WinZIP self-extracting archive that contains ReadMe.txt, ReadMeSST.txt, MAX7301.EXE, DLPortIO.DLL, and MSVBVM50.DLL. The default download directory is C:\MAX7300. MSVBVM50.DLL may be deleted if the library is already registered on the computer.

To install to a Windows NT, 2000, or XP platform, [download the MAX7300-NT.EXE file](#) (2.3MB). This is a WinZIP self-extracting archive that contains ReadMe.txt, ReadMeSST.txt, MAX7300.EXE, PORT95NT.EXE, and MSVBVM50.DLL. The default download directory is C:\MAX7300. PORT95NT.EXE is the install program for the DriverLINX drivers which installs and registers the DLPortIO.DLL library and DLPortIO.SYS driver. PORT95NT.EXE can be deleted after installation. Windows 95, 98, 98SE, ME users can also use this installation procedure if they wish.

Connecting a MAX7300 or MAX7301 to the Parallel Port

This utility uses 3 of the 8 parallel port printer output lines to simulate SPI serial interface activity, and another 2 output lines to simulate I²C serial interface activity. Parallel port control input lines are used to read back SPI data, I²C data, and interrupt status. Multiple (up to 16, daisy-chained) MAX7301s and/or multiple (up to 16, configured with different I²C addresses) MAX7300s may be operated at once. Either the LPT1 or LPT2 port may be selected from the software. The port can be a standard, ECP, or EPP type. The port connections are shown in **Figure 1**.

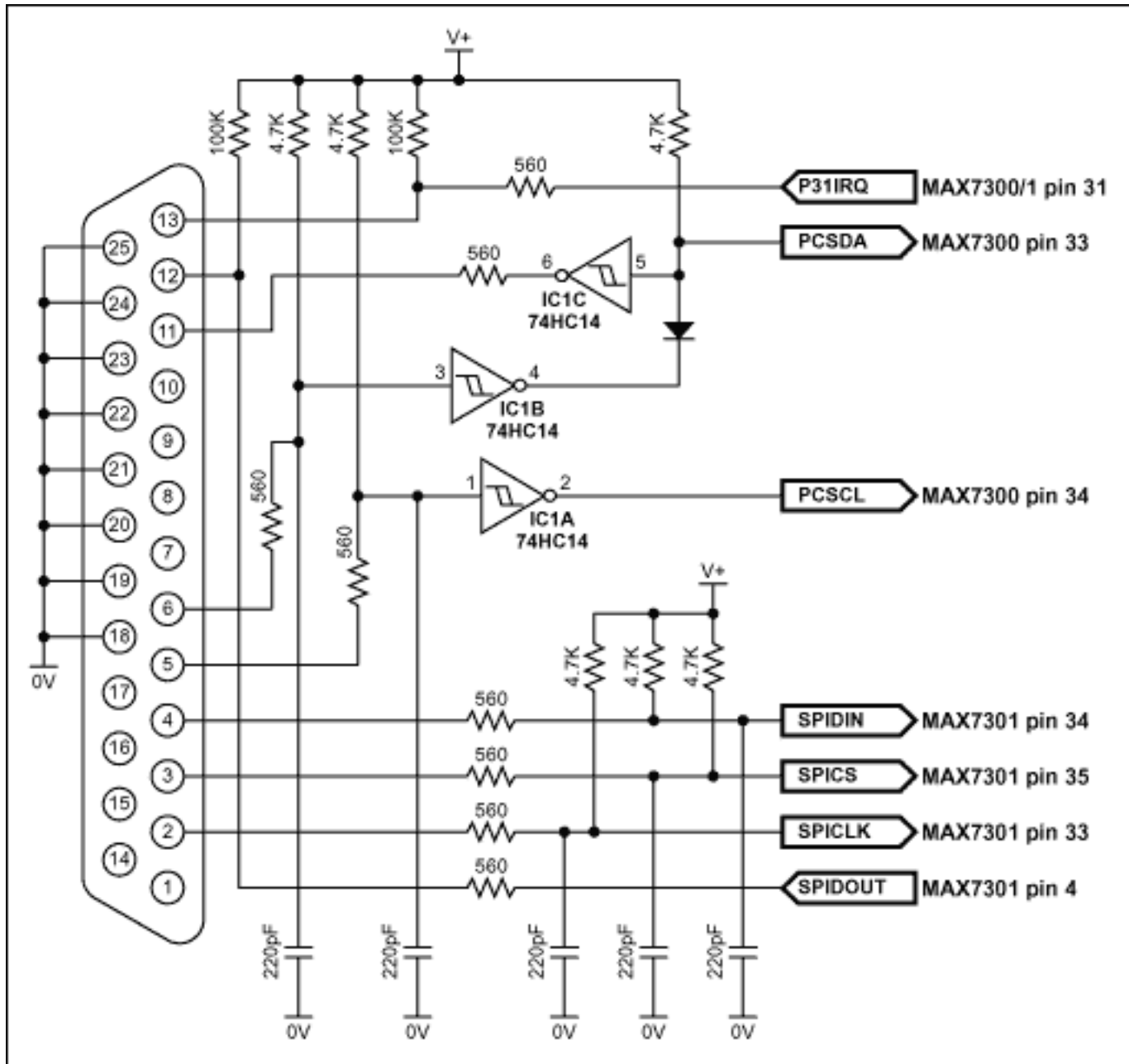

Figure 1. The MAX7300 and MAX7301 connections to the parallel port.

The program brings up 3 windows on startup. These are the main control, I/O control, and port control windows. The register settings on start-up mirror the register power-up conditions of the MAX7300 and MAX7301.

The main control is shown in **Figure 2** below. The 'Driver type' radio buttons select whether the software will transmit to MAX7301 (using the SPI connection) or the MAX7300 (using the I²C connection).

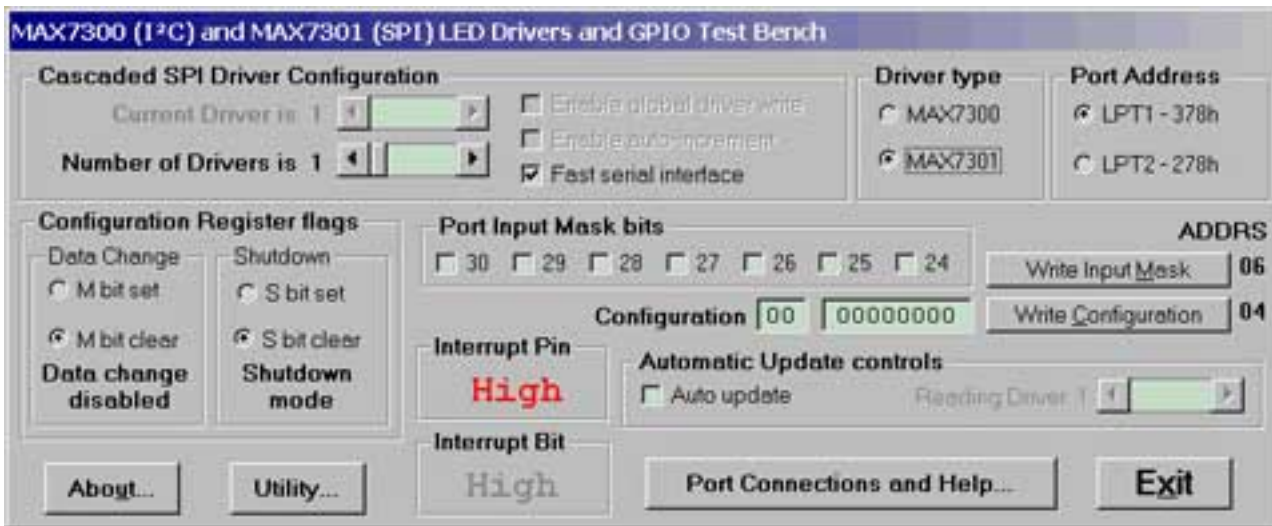

Figure 2. Program display on startup.

In SPI mode, the software controls up to 16 MAX7301 drivers. The drivers are presumed to be cascaded, (i.e., the DOUT pin of the first MAX7301 connects to the DIN pin of the second MAX7301, whose DOUT pin connects to the DIN pin of the third MAX7301, and so on). The total number of MAX7301 devices is set by the 'Number of Drivers' slider. When this is set to more than 1, the 'Enable global driver write' and 'Enable auto-increment' check boxes are available. When 'Enable global driver write' is clear, only the MAX7301 driver selected by the 'Current Driver' slider is written to when a write command is selected - the others receive the no-op instruction. When 'Enable global driver write' is checked, all the MAX7301 drivers are written to with the same data. When 'Enable auto-increment' is checked, the current driver number is automatically incremented after each write action. This allows the user to quickly send the same data for a series of MAX7301 drivers.

The SPI interface connection to the parallel port can be tested with the 'Test Stream' facility which can be found under 'Port Connections and Help...' when the program is running. The 'Test Stream' facility transmits the no-op instruction continuously to the MAX7301(s) (as set by the 'Number of Drivers' slider) allowing the interface connections to be verified without affecting register contents.

In I²C mode, the software controls up to 16 MAX7300 drivers. The first driver is presumed to be set to address 1000000x, with the addresses of subsequent devices increasing to 1001111x for the last device. To access, for example, a single MAX7300 driver at address 1001111x, simply set the 'Number of Drivers' slider to 16 and then the 'Current Driver' slider to 16, address 1001111x. The main form in I²C mode is shown in **Figure 3**.

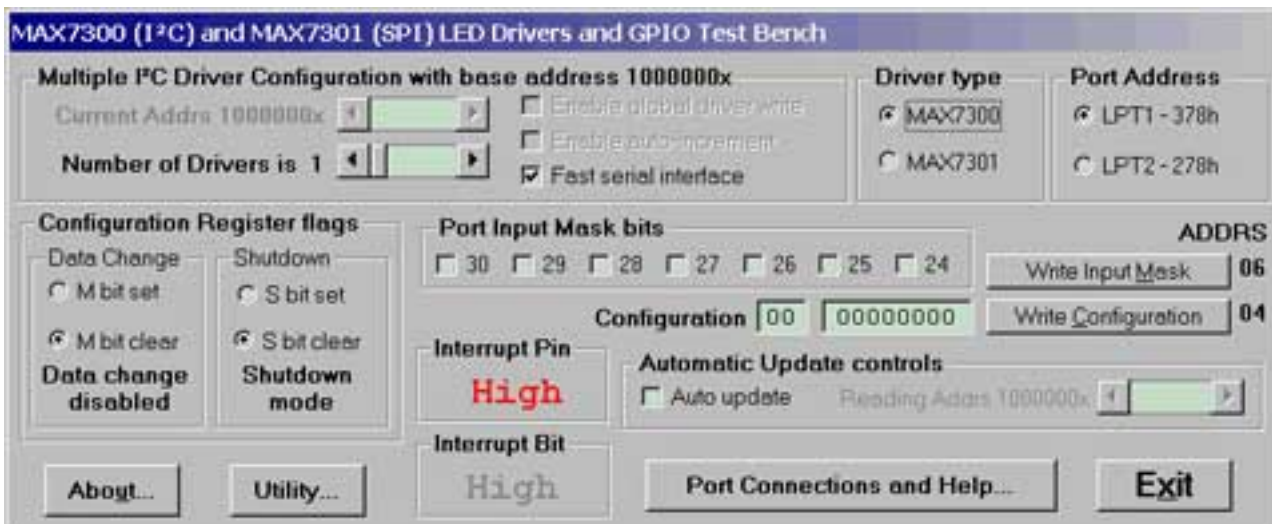

Figure 3. I²C program display.

The I²C interface connection to the parallel port can be tested with the 'Test Stream' facility which can be found under 'Port Connections and Help...' when the program is running. The 'Test Stream' facility transmits the no-op instruction continuously to all MAX7300(s) (as set by the 'Number of Drivers' slider) allowing the interface connections to be verified without affecting register contents.

The 'Fast serial interface' check box sets the serial interface speed for both SPI and I²C interface types. When checked, serial interface runs at machine-dependent full speed up to 1 Mbits/sec; unchecked, the speed is limited to 500 bits/sec maximum. The slow speed may be useful when connecting over very long cables.

The program will normally only communicate with the target driver (or drivers) when a 'Write' or 'Read' button is pressed. However, the program attempts to monitor an interrupt output pin presumed to be connected to the parallel port pin 13. This is displayed on the main window and displays status as High or Low.

The 'Automatic Update control' button, when checked, makes the program continually poll all 28 port input registers and the interrupt register bit. The reading rate depends on the setting of the 'Fast serial interface' check box, and is many times a second (Fast) or every many seconds (Slow). Note: slow mode is very slow! The 'Reading driver x' slider allows the user to set the device being automatically read independently to the driver(s) accessible through the 'Current driver' control.

The main window is the route to Exit the program. The Exit button, or pressing the Esc key on the main window, closes all 3 windows. Pressing the Esc key in one of the other 2 windows takes the user to the main window; therefore, pressing the Esc key twice will close the program quickly. Before closing, the program stores the last settings for device configuration in a file called MAX7300.ini in the same directory that the program was executed from. Nothing is written to Windows registry. The settings includes the positions of the 3 windows, and the interface settings on the main window. If the MAX7300.ini doesn't exist then it is created; otherwise it is overwritten. To restore program default settings, or if the MAX7300.ini is corrupted, simply delete the MAX7300.ini file.

Figures 4 and 5 show snapshots of the other two windows.

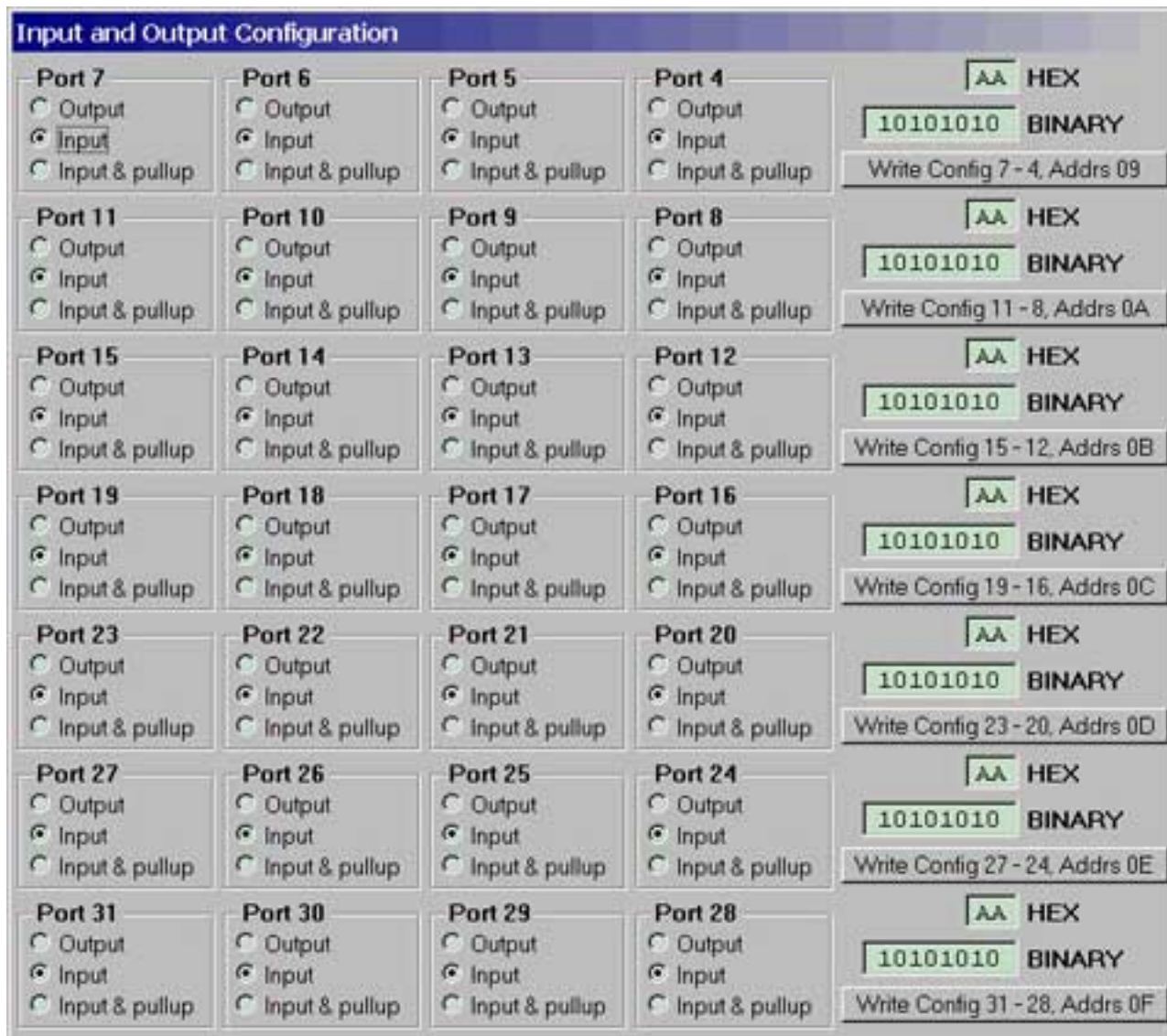

Figure 4. I/O configuration window.

Port Registers										
PORT	WRITE	ADDRS	ADDRS	READ	ADDRS	ADDRS				
Port 0	0	Write Port 0	20	Write 7 - 0	40	? Read Port 0	A0	Read 7 - 0	C0	
Port 1	0	Write Port 1	21	Write 8 - 1	41	? Read Port 1	A1	Read 8 - 1	C1	
Port 2	0	Write Port 2	22	Write 9 - 2	42	? Read Port 2	A2	Read 9 - 2	C2	
Port 3	0	Write Port 3	23	Write 10 - 3	43	? Read Port 3	A3	Read 10 - 3	C3	
Port 4	0	Write Port 4	24	Write 11 - 4	44	? Read Port 4	A4	Read 11 - 4	C4	
Port 5	0	Write Port 5	25	Write 12 - 5	45	? Read Port 5	A5	Read 12 - 5	C5	
Port 6	0	Write Port 6	26	Write 13 - 6	46	? Read Port 6	A6	Read 13 - 6	C6	
Port 7	0	Write Port 7	27	Write 14 - 7	47	? Read Port 7	A7	Read 14 - 7	C7	
Port 8	0	Write Port 8	28	Write 15 - 8	48	? Read Port 8	A8	Read 15 - 8	C8	
Port 9	0	Write Port 9	29	Write 16 - 9	49	? Read Port 9	A9	Read 16 - 9	C9	
Port 10	0	Write Port 10	2A	Write 17 - 10	4A	? Read Port 10	AA	Read 17 - 10	CA	
Port 11	0	Write Port 11	2B	Write 18 - 11	4B	? Read Port 11	AB	Read 18 - 11	CB	
Port 12	0	Write Port 12	2C	Write 19 - 12	4C	? Read Port 12	AC	Read 19 - 12	CC	
Port 13	0	Write Port 13	2D	Write 20 - 13	4D	? Read Port 13	AD	Read 20 - 13	CD	
Port 14	0	Write Port 14	2E	Write 21 - 14	4E	? Read Port 14	AE	Read 21 - 14	CE	
Port 15	0	Write Port 15	2F	Write 22 - 15	4F	? Read Port 15	AF	Read 22 - 15	CF	
Port 16	0	Write Port 16	30	Write 23 - 16	50	? Read Port 16	B0	Read 23 - 16	D0	
Port 17	0	Write Port 17	31	Write 24 - 17	51	? Read Port 17	B1	Read 24 - 17	D1	
Port 18	0	Write Port 18	32	Write 25 - 18	52	? Read Port 18	B2	Read 25 - 18	D2	
Port 19	0	Write Port 19	33	Write 26 - 19	53	? Read Port 19	B3	Read 26 - 19	D3	
Port 20	0	Write Port 20	34	Write 27 - 20	54	? Read Port 20	B4	Read 27 - 20	D4	
Port 21	0	Write Port 21	35	Write 28 - 21	55	? Read Port 21	B5	Read 28 - 21	D5	
Port 22	0	Write Port 22	36	Write 29 - 22	56	? Read Port 22	B6	Read 29 - 22	D6	
Port 23	0	Write Port 23	37	Write 30 - 23	57	? Read Port 23	B7	Read 30 - 23	D7	
Port 24	0	Write Port 24	38	Write 31 - 24	58	? Read Port 24	B8	Read 31 - 24	D8	
Port 25	0	Write Port 25	39	Write 32 - 25	59	? Read Port 25	B9	Read 32 - 25	D9	
Port 26	0	Write Port 26	3A	Write 33 - 26	5A	? Read Port 26	BA	Read 33 - 26	DA	
Port 27	0	Write Port 27	3B	Write 34 - 27	5B	? Read Port 27	BB	Read 34 - 27	DB	
Port 28	0	Write Port 28	3C	Write 35 - 28	5C	? Read Port 28	BC	Read 25 - 28	DC	
Port 29	0	Write Port 29	3D	Write 36 - 29	5D	? Read Port 29	BD	Read 26 - 29	DD	
Port 30	0	Write Port 30	3E	Write 37 - 30	5D	? Read Port 30	BD	Read 37 - 30	DE	
Port 31	0	Write Port 31	3F	Write 38 - 31	5D	? Read Port 31	BF	Read 38 - 31	DF	

Set and write all ports low
Set and write all ports high
Read all ports

Figure 5. Port registers window.

Windows is a registered trademark of Microsoft Corp.
 SPI is a trademark of Motorola, Inc.
 DriverLINX is a trademark of Scientific Software Tools, Inc.

For technical questions and support: <http://www.maxim-ic.com/support>

For samples: <http://www.maxim-ic.com/samples>

Other questions and comments: <http://www.maxim-ic.com/contact>

Related Parts

MAX7300: [QuickView](#) -- [Full \(PDF\) Data Sheet](#) -- [Free Samples](#)

MAX7301: [QuickView](#) -- [Full \(PDF\) Data Sheet](#) -- [Free Samples](#)

AN2852, AN 2852, APP2852, Appnote2852, Appnote 2852

Copyright © by Maxim Integrated Products

Additional legal notices: <http://www.maxim-ic.com/legal>