

APPLICATION NOTE 2768

Ultra-Low Quiescent Supply Current 125kHz ASK Receiver

There is an emerging automotive market: Tire Pressure Monitoring Systems (TPMS). These systems, which will soon be mandated for new cars, monitor the tire pressure and alert the driver when pressure is outside specifications. Proper tire pressure enhances fuel economy and vehicle safety.

Powering these systems is a complex challenge. Components are built into the wheel, so the batteries used must be light in weight. Batteries must offer a seven-year life, as they are permanently molded into the modules and cannot be replaced.

Because of the difficulty in providing a connection between the vehicle and a rotating wheel, wireless systems are a common solution. Pressure information is transmitted via a RF channel at a frequency that varies with the country (usually, 315MHz, 434MHz or 868MHz). Transmitters are generally switched on and off, to prevent excess interference and improve battery life.

Some systems use a mechanical switch, others use an algorithm which cycles the transmitter based on rotation speed. Many designs use a LFRF (low-frequency RF) solution: A 125kHz magnetic field wakes the tire-mounted TPMS module, which transmits the pressure-related signal and returns to sleep mode. The module is controlled by electronics on the vehicle. The TPMS module needs a LFRF receiver with very low power consumption.

This application note describes an ASK receiver at 125kHz with a 2.1V supply voltage requirement and only 4µA typical supply current when there is no LFRF trigger signal. Sensivity is adjustable and is typically around 5mV_{peak-to-peak}. The design is based on the best speed/consumption comparator on the market : the MAX9075. It is available in a tiny SC70 package

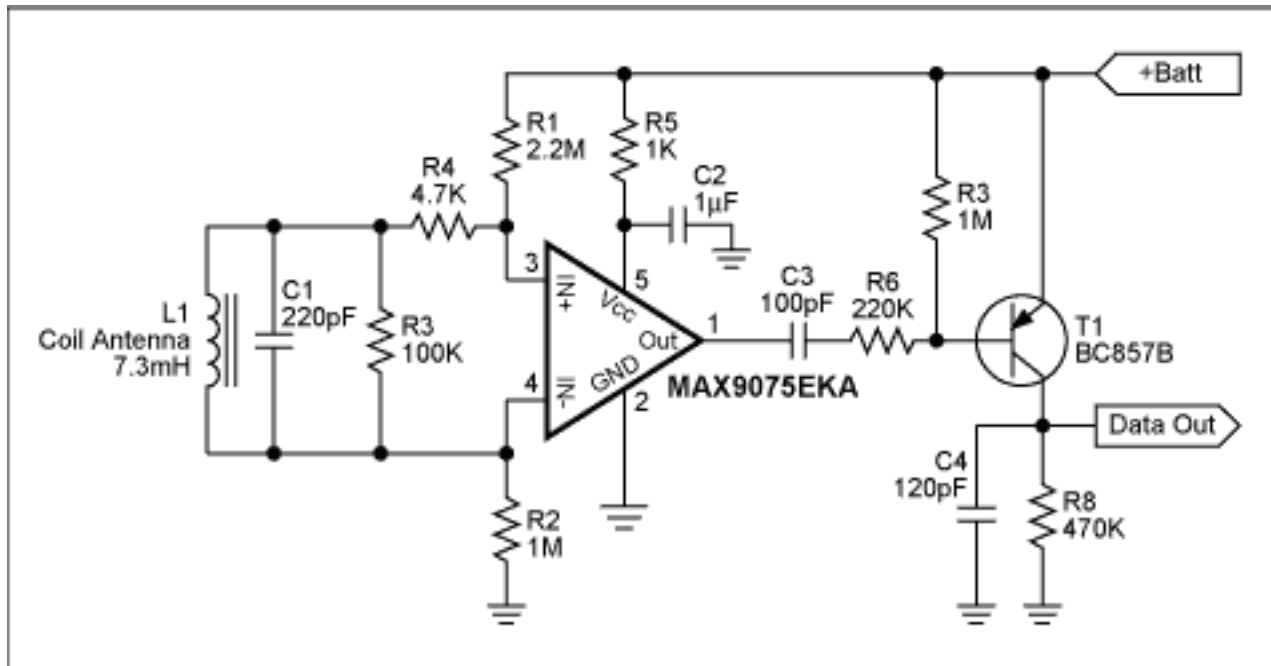

Figure 1.

The antenna is a coil, tuned with a fixed or adjustable capacitor. The loaded Q factor is set by R3 and can be 10 or more, depending on the accuracy of the coil and the capacitors and the desired data rate.

The MAX9075 acts as a limiting amplifier. A single transistor is used for detection. The values of the detector section are adjusted according to the desired data rate.

R1, R2 is the bias resistor network. The bias current is about 1 μ A with a new lithium battery (\approx 3.2V). R4 generates an offset to adjust the sensitivity. If R4=0, sensitivity is optimum but there is a risk of oscillation because the MAX9075 has no internal hysteresis. In this case, the real sensitivity is unknown because it depends upon internal offset. It is typically \pm 1mV but the maximum is \pm 8mV.

According to the global offset, the output state of the comparator is unknown. C3 eliminates the "DC level." In this example, the detector transistor is a PNP, and the demodulated output is positive. DataOut \approx Vcc if LF signal is present, and DataOut \approx 0V without the LFRF input signal.

R5/C2 is the power supply filter. It has about a 1ms rise time (cycling mode).

If a high magnetic field can be applied at the antenna, a dual diode, such as the BAV99, is necessary between pins 3 and 4 of U1, to limit the peak/peak voltage applied to the comparator's inputs. In TPMS systems, the dynamic range of the input signal is not very high because the distance between the emitting coil and the TPMS module is fairly constant.

An optional nanopower comparator, such as the MAX9117 in SC70, can be used to ensure a good square output waveform (see **Figure 2**). Its supply current is only 600nA typical at 1.8V and it integrates a voltage reference internally connecting to IN- (pin4) which is AC decoupled with C5=1nF.

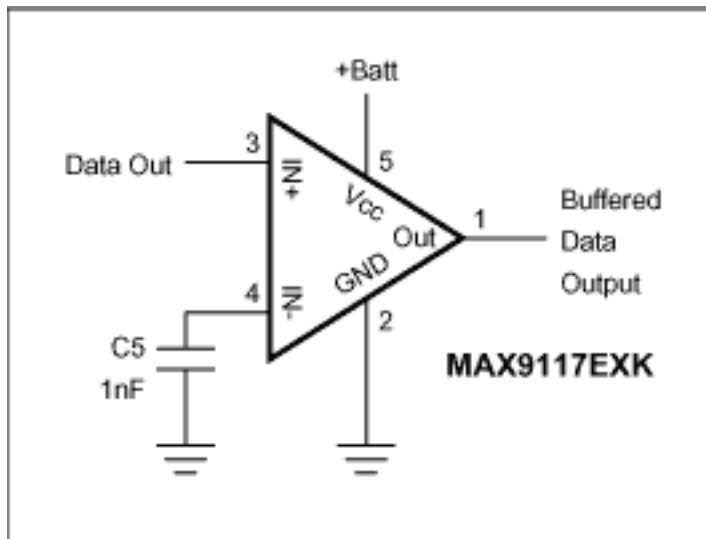

Figure 2.

Application Note 2768: <http://www.maxim-ic.com/an2768>

More Information

For technical questions and support: <http://www.maxim-ic.com/support>

For samples: <http://www.maxim-ic.com/samples>

Other questions and comments: <http://www.maxim-ic.com/contact>

Related Parts

MAX9075: [QuickView](#) -- [Full \(PDF\) Data Sheet](#) -- [Free Samples](#)

MAX9117: [QuickView](#) -- [Full \(PDF\) Data Sheet](#) -- [Free Samples](#)

AN2768, AN 2768, APP2768, Appnote2768, Appnote 2768

Copyright © by Maxim Integrated Products

Additional legal notices: <http://www.maxim-ic.com/legal>