



APPLICATION NOTE 272

## IF Tank Design for the MAX2360

*Abstract: This application note presents three voltage-controlled oscillator (VCO) designs for popular IF frequencies of 130MHz, 165MHz, and 380MHz. These designs reduce the number of iterations required for optimized results. Analysis can be accomplished with a simple spreadsheet program.*

### Additional Information

- [Wireless Product Line Page](#)
- [Quick View Data Sheet for the MAX2360/MAX2362/MAX2364](#)
- [Applications Technical Support](#)

## Introduction

This application note presents three voltage-controlled oscillator (VCO) designs for popular IF frequencies of 130MHz, 165MHz, and 380MHz. These designs reduce the number of iterations required for optimized results. Analysis can be accomplished with a simple spreadsheet program.

## VCO Design

**Figure 2** shows the differential tank circuit used for the MAX2360 IF VCO. For analysis purposes, the tank circuit must be reduced to an equivalent simplified model. **Figure 1** depicts the basic VCO model. The frequency of oscillation can be characterized by EQN1:

$$f_{osc} = \frac{1}{2\pi\sqrt{L(C_{int} + C_t)}}$$

EQN1

$f_{osc}$  = frequency of oscillation

L = inductance of the coil in the tank circuit

$C_{int}$  = internal capacitance of the MAX2360 tank port

$C_t$  = total equivalent capacitance of the tank circuit

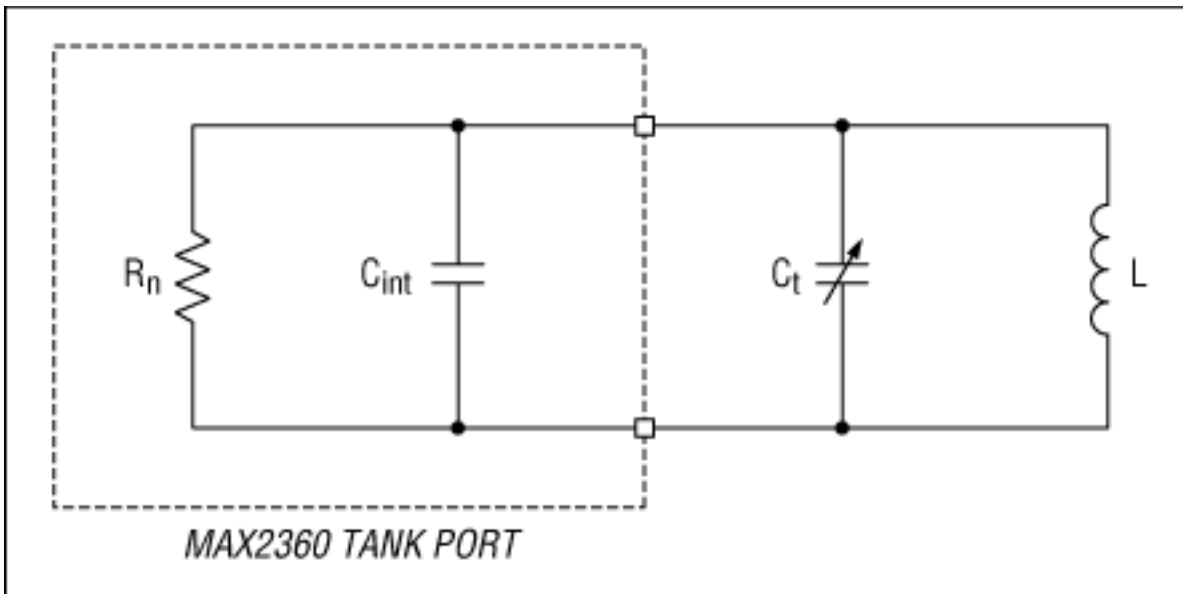

Figure 1. Basic VCO model.

$R_n$  = equivalent negative resistance of the MAX2360 tank port

$C_{int}$  = internal capacitance of the MAX2360 tank port

$C_t$  = total equivalent capacitance of the tank circuit

$L$  = inductance of the coil in the tank circuit

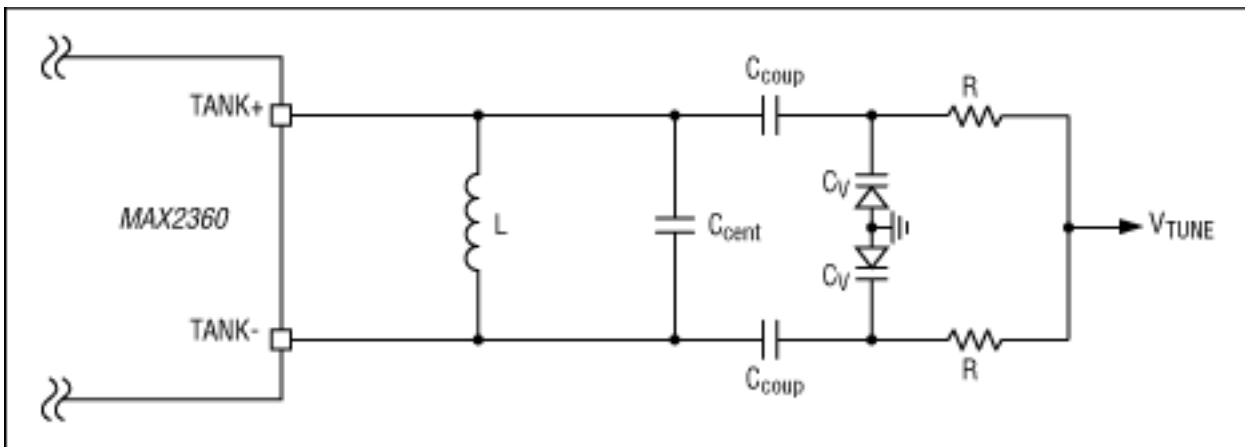

Figure 2. The MAX2360 tank circuit.

Inductor  $L$  resonates with the total equivalent capacitance of the tank and the internal capacitance of the oscillator ( $C_t + C_{int}$ ) (see Figure 1).  $C_{coup}$  provides DC block and couples the variable capacitance of the varactor diodes to the tank circuit.  $C_{cent}$  is used to center the tank's oscillation frequency to a nominal value. It is not required but adds a degree of freedom by allowing you to fine-tune resonance between inductor values. Resistors ( $R$ ) provide reverse-bias voltage to the varactor diodes via the tune voltage line ( $V_{tune}$ ). Their value should be chosen large enough so as not to affect loaded tank  $Q$  but small enough so that  $4kTBR$  noise is negligible. The resistors' noise voltage gets modulated by  $K_{vco}$ , producing phase noise. Capacitance  $C_V$  is the variable tuning component in the tank. The capacitance of the varactor diode ( $C_V$ ) is a function of reverse-bias voltage (see Appendix A for the varactor model).  $V_{tune}$  is the tuning voltage from a phase-locked loop (PLL).

**Figure 3** shows the lumped  $C_{stray}$  VCO model. Parasitic capacitance and inductance plague every RF circuit. In order to predict the frequency of oscillation, the parasitic elements must be taken into account. The circuit in Figure 3 lumps the parasitic elements in one capacitor called  $C_{stray}$ . The frequency of oscillation can be characterized by EQN2:

$$f_{osc} = \frac{1}{2\pi \sqrt{L \left[ C_{int} + C_{cent} + C_{stray} + \left( \frac{1}{\frac{2}{C_{coup}} + \frac{2}{C_V + C_{vp}}} \right) \right]}}$$

EQN2

- L = inductance of the coil in the tank circuit
- C<sub>int</sub> = internal capacitance of the MAX2360 tank port
- C<sub>cent</sub> = tank capacitor used to center oscillation frequency
- C<sub>stray</sub> = lumped stray capacitance
- C<sub>coup</sub> = tank capacitor used to couple the varactor to the tank
- C<sub>V</sub> = net variable capacitance of the varactor diode (including series inductance)
- C<sub>vp</sub> = varactor pad capacitance

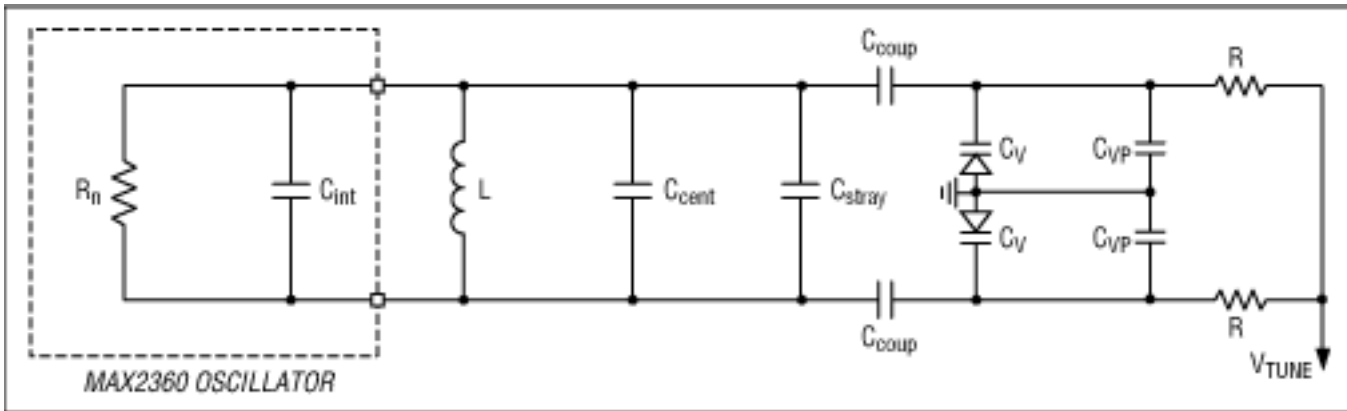

Figure 3. Lumped C<sub>stray</sub> model.

**Figure 4** depicts the detailed VCO model. It takes into account the capacitance of the pads but does not include the effects of series inductance for simplicity. C<sub>stray</sub> is defined as:

$$C_{stray} = C_L + \frac{C_{LP}}{2} + C_{DIFF}$$

EQN3

- C<sub>L</sub> = capacitance of the inductor
- C<sub>LP</sub> = capacitance of inductor pads
- C<sub>DIFF</sub> = capacitance due to parallel traces

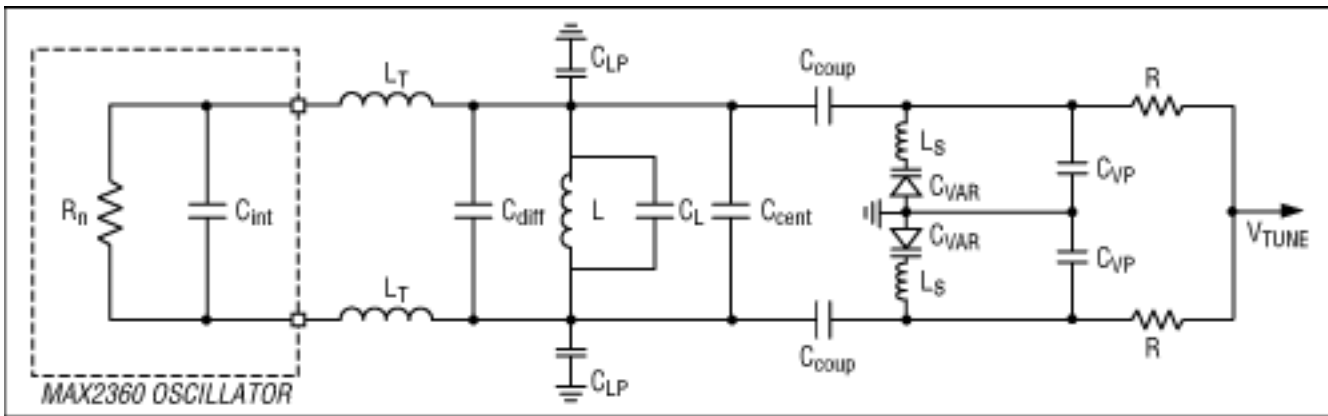

Figure 4. Detailed VCO model.

$R_n$  = equivalent negative resistance of the MAX2360 tank port

$C_{int}$  = internal capacitance of the MAX2360 tank port

$L_T$  = inductance of series trace to the inductor tank circuit

$C_{DIFF}$  = capacitance due to parallel traces

$L$  = inductance of the coil in the tank circuit

$C_L$  = capacitance of the inductor

$C_{LP}$  = capacitance of inductor pads

$C_{cent}$  = tank capacitor used to center oscillation frequency

$C_{coup}$  = tank capacitor used to couple the varactor to the tank

$C_{var}$  = variable capacitance of the varactor diode

$C_{vp}$  = varactor pad capacitance

$L_S$  = series inductance of the varactor

$R$  = resistance of varactor reverse-bias resistors

To simplify analysis, inductance  $L_T$  is ignored in this design. The effects of  $L_T$  are more pronounced at higher frequencies. To mathematically model the shift in frequency due to  $L_T$  with the spreadsheets that follow, the value of  $C_{DIFF}$  can be increased appropriately. Minimize inductance  $L_T$  to prevent undesired series resonance. This can be accomplished by making the traces short.

## Tuning Gain

Tuning gain ( $K_{VCO}$ ) must be minimized for best closed-loop phase noise. Resistors in the loop filter as well as the resistors "R" (Figure 2) will produce broadband noise. Broadband thermal noise ( $V_n = \sqrt{4kTB R}$ ) will modulate the VCO by  $K_{VCO}$ , which is measured in MHz/V. There are two ways to minimize  $K_{VCO}$ . One is to minimize the frequency range over which the VCO must tune. The second way is to maximize the tuning voltage available. To minimize the frequency range over which the VCO must tune, tight tolerance components must be used, as will be shown. To maximize tuning voltage, a charge pump with a large compliance range is needed. This is usually accomplished by using a larger  $V_{CC}$ . The compliance range for the MAX2360 is 0.5V to  $V_{CC}-0.5V$ . In battery-powered applications, the compliance range is usually fixed by the battery voltage or regulator.

## Basic Concept for Trimless Design

VCO design manufacturability with real-world components will require an error budget analysis. In order to design a VCO to oscillate at a fixed frequency ( $f_{osc}$ ), the tolerance of components must be taken into consideration. Tuning gain ( $K_{VCO}$ ) must be designed into the VCO to account for these component tolerances. The

tighter the component tolerance, the smaller the tuning gain and the lower the closed-loop phase noise. For the worst-case error budget design, we will look at three VCO models:

1. Maximum-value components (EQN5)
2. Nominal tank, all components perfect (EQN2)
3. Minimum-value components (EQN4)

All three VCO models must cover the desired nominal frequency. Figure 5 shows how the three designs must converge to provide a manufacturable design solution. Observations of EQN1 and **Figure 5** reveal that *minimum-value* components shift the oscillation frequency *higher*, and *maximum-value* components shift the oscillation frequency *lower*.

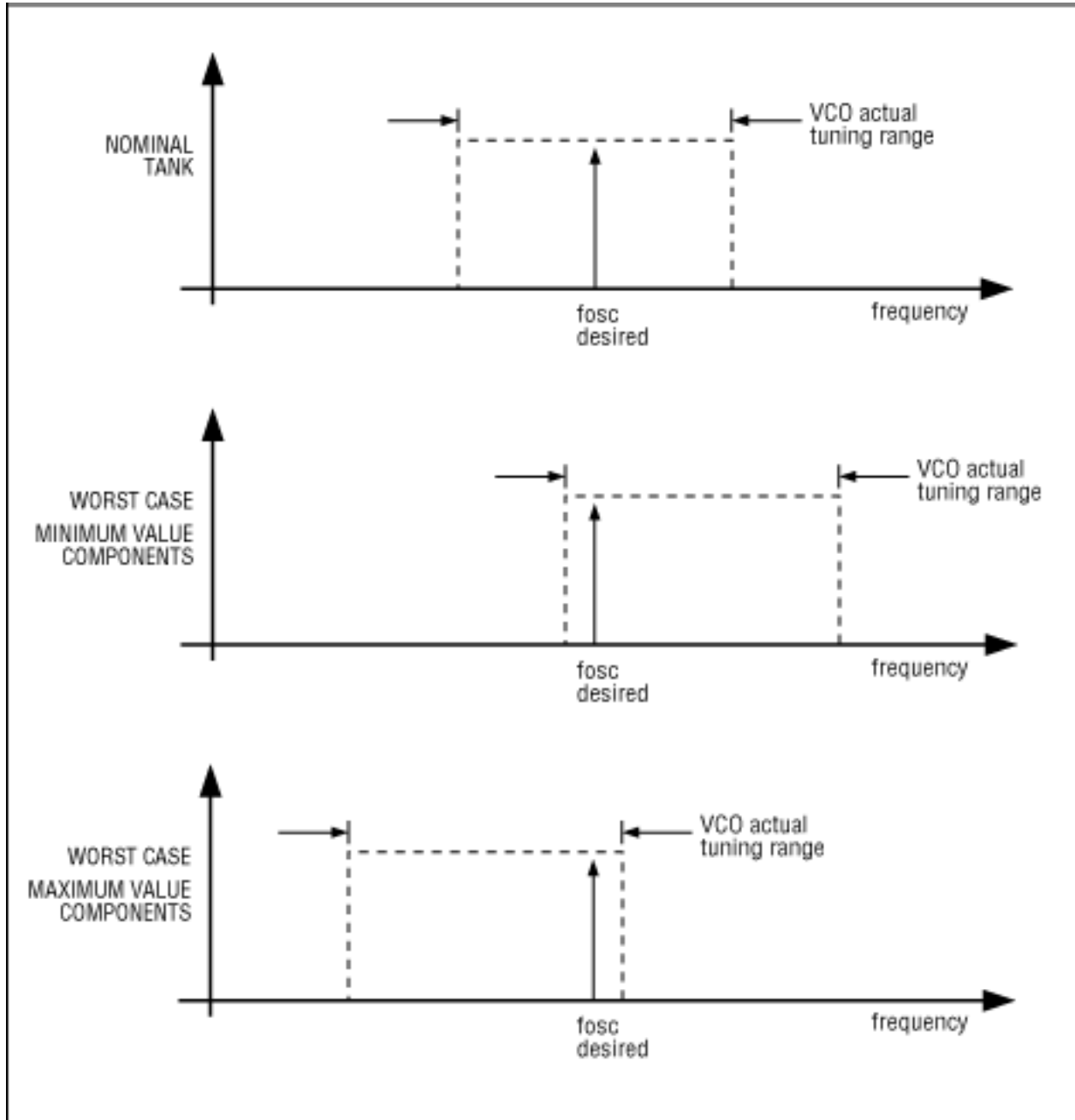

Figure 5. Worst-case and nominal-tank centering.

Minimum tuning range must be used in order to design a tank with the best closed-loop phase noise. Therefore, the nominal tank should be designed to cover the center frequency with overlap to take into account device tolerance. The worst-case high-tune tank and worst-case low-tune tank should tune just to the edge of the desired oscillation frequency. EQN2 can be modified by component tolerance to produce a worst-case high-tune tank EQN4 and worst-case low-tune tank EQN5.

$$f_{osc} = \frac{1}{2\pi \sqrt{L(1-T_L) \left[ C_{INT}(1-T_{C_{INT}}) + C_{CENT}(1-T_{C_{CENT}}) + C_{STRAY} + \frac{1}{\frac{2}{C_{COUP}(1-T_{C_{COUP}})} + \frac{2}{C_V(1-T_{C_V})} + C_{VP}} \right]}} \quad \text{EQN4}$$

$$f_{osc} = \frac{1}{2\pi \sqrt{L(1+T_L) \left[ C_{INT}(1+T_{C_{INT}}) + C_{CENT}(1-T_{C_{CENT}}) + C_{STRAY} + \frac{1}{\frac{2}{C_{COUP}(1+T_{C_{COUP}})} + \frac{2}{C_V(1+T_{C_V})} + C_{VP}} \right]}} \quad \text{EQN5}$$

$T_L$  = % tolerance of inductor (L)

$T_{C_{INT}}$  = % tolerance of capacitor ( $C_{INT}$ )

$T_{C_{CENT}}$  = % tolerance of capacitor ( $C_{CENT}$ )

$T_{C_{COUP}}$  = % tolerance of capacitor ( $C_{COUP}$ )

$T_{C_V}$  = % tolerance of varactor capacitance ( $C_V$ )

EQN4 and EQN5 assume that the strays do not have a tolerance.

## General Design Procedure

### Step 1

Estimate or measure pad capacitance and other strays. The stray capacitance on the MAX2360 Rev A EV Kit has been measured with a Boonton Model 72BD capacitance meter.  $C_{LP} = 0.981\text{pF}$ ,  $C_{VP} = 0.78\text{pF}$ ,  $C_{DIFF} = 0.118\text{pF}$ .

### Step 2

Determine the value for capacitance  $C_{int}$ . This can be found in the MAX2360/MAX2362/MAX2364 Data Sheet on page 5. The typical operating characteristic TANK 1/S11 vs. FREQUENCY shows the equivalent parallel RC values for several popular LO frequencies. Keep in mind that the LO frequency is twice the IF frequency.

### Example:

For an IF frequency of 130MHz, the LO operates at 260MHz. From the 1/s11 chart,  $R_n = -1.66\text{k}\Omega$  and  $C_{int} = 0.31\text{pF}$ .

### Step 3

Choose an inductor. A good starting point is using the geometric mean. This is an iterative process.

$$L = \sqrt{\frac{1}{(2\pi f_{osc})^2 \times 1 \times 10^{-21}}}$$

EQN6

This equation assumes L in (nH) and C in (pF) ( $1 \times 10^{-9} \times 1 \times 10^{-12} = 1 \times 10^{-21}$ ). L = 19.3nH for a  $f_{osc} = 260.76$ MHz. This implies a total tank capacitance C = 19.3pF. An appropriate initial choice for an inductor would be 18nH Coilcraft 0603CS-18NXGBC 2% tolerance.

When choosing an inductor with finite step sizes, the following formula EQN6.1 is useful. The total product LC should be constant for a fixed oscillation frequency  $f_{osc}$ .

$$LC = \frac{1}{(2\pi f_{osc})^2 \times 1 \times 10^{-21}}$$

EQN6.1

LC = 372.5 for a  $f_{osc} = 260.76$ MHz. The trial-and-error process with the spreadsheet in Table1 yielded an inductor value of 39nH 5% with a total tank capacitance of 9.48pF. The LC product for the tank in **Figure 6** is 369.72, which is close enough to the desired LC product of 372.5. One can see this is a useful relationship to have on hand. For best phase noise, choose a high Q inductor like the Coilcraft 0603CS series. Alternatively, a microstrip inductor can be used if the tolerance and Q can be controlled reasonably.

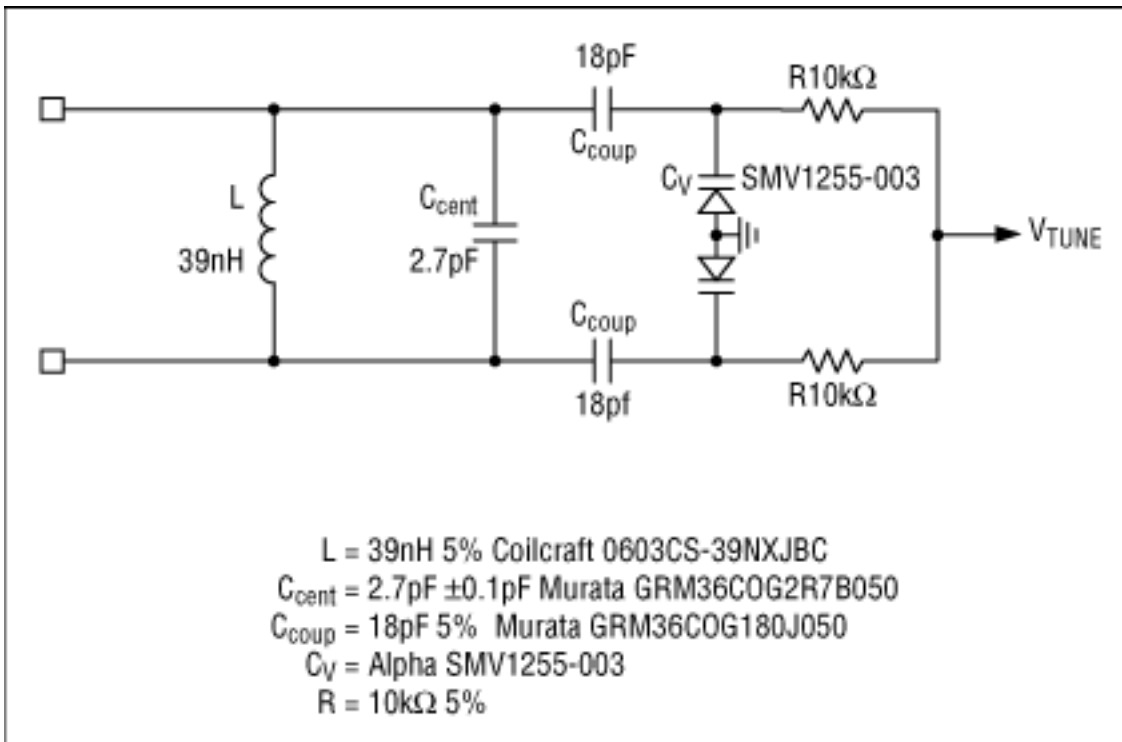

Figure 6. 130.38MHz IF tank schematic.

## Step 4

Determine the PLL compliance range. This is the range the VCO tuning voltage ( $V_{tune}$ ) is designed to work over. For the MAX2360, the compliance range is 0.5V to  $V_{CC} - 0.5V$ . For a  $V_{CC} = 2.7V$ , this would set the compliance range to 0.5 to 2.2V. The charge-pump output sets this limit. The voltage swing on the tank is  $1V_{p-p}$  centered at

1.6VDC. Even with large values for  $C_{\text{coup}}$ , the varactor diodes are not forward-biased. This is a condition to be avoided, as the diode rectifies the AC signal on the tank pins, producing undesirable spurious response and loss of lock in a closed-loop PLL.

## Step 5

Choose a varactor. Look for a varactor with good tolerance over your specified compliance range. Keep the series resistance small. For a figure of merit, check that the self-resonant frequency of the varactor is above the desired operating point. Look at the  $C_V(2.5V)/C_V(0.5V)$  ratio at your voltage compliance range. If the coupling capacitors  $C_{\text{coup}}$  were chosen large, then the maximum tuning range can be calculated using EQN2. Smaller values of capacitor  $C_{\text{coup}}$  reduce this effective frequency tuning range. When choosing a varactor, it should have a tolerance specified at your given compliance-range mid and end points. Select a hyperabrupt varactor such as the Alpha SMV1763-079 for the linear tuning range. Take the value for total tank capacitance, and use that for  $C_{\text{jo}}$  of the varactor. Remember that  $C_{\text{coup}}$  reduces the net capacitance coupled to the tank.

## Step 6

Pick a value for  $C_{\text{coup}}$ . Large values of  $C_{\text{coup}}$  increase the tuning range by coupling more of the varactor in the tank at the expense of decreasing tank loaded Q. Smaller values of  $C_{\text{coup}}$  increase the effective Q of the coupled varactor and loaded Q of the tank at the expense of reducing the tuning range. Typically this value is chosen as small as possible, while still getting the desired tuning range. Another benefit of choosing a small value for  $C_{\text{coup}}$  is that it reduces the voltage swing across the varactor diode. This helps thwart forward-biasing the varactor.

## Step 7

Pick a value for  $C_{\text{cent}}$ , which is usually around 2pF or greater for tolerance purposes. Use  $C_{\text{cent}}$  to center up the VCO's frequency.

## Step 8

Iterate with the spreadsheet.

## MAX2360VCO Tank Designs for IF Frequencies of 130.38MHz, 165MHz, and 380MHz

The following spreadsheets show designs for several popular IF frequencies for the MAX2360. Keep in mind that the LO oscillates at twice the desired IF frequency.

 Light grey indicates calculated values

 Darker grey indicates user input

**Table 1. 130.38MHz IF Tank Design**

MAX2360 Tank Design and Tuning Range for 130.38MHz IF Frequency				
Total Tank Capacitance vs. V tune				
V tune	Total C	Ct (Nominal)	Ct (Low)	Ct (High)

0.5V	Ct high	10.9296pF	10.1242pF	11.6870pF
1.375V	Ct mid	9.4815pF	8.4068pF	10.4077pF
2.2V	Ct low	8.0426pF	6.9014pF	9.0135pF

Tank Components	Tolerance		
C coup	18pF	0.9pF	5%
C cent	2.7pF	0.1pF	4%
C stray	0.69pF		
L	39nH	5.00%	
C int	0.31pF	10.00%	

Parasitics and Pads (C stray)			
Due to Q	C L		0.08pF
Ind. pad	C Lp		0.981pF
Due to	C diff		0.118pF
Var. pad	C vp		0.78pF

Varactor Specs			
Alpha SMV1255-003			
Cjo	82pF	Varactor Tolerance	
Vj	17V	0.5V	19.00%
M	14	1.5V	29.00%
Cp	0pF	2.5V	35.00%
Rs	1Ω	Reactance	
Ls	1.7nH	X Ls	2.79
Freq	260.76MHz		

Nominal Varactor		X c	Net Cap
Cv high	54.64697pF	-11.16897	72.80216pF
Cv mid	27.60043pF	-22.11379	31.57772pF
Cv low	14.92387pF	-40.89758	16.01453pF

Negative Tol Varactor (Low Capacitance)			
Cv high	44.26404pF	-13.78885	55.46841pF
Cv mid	19.59631pF	-31.14619	21.52083pF
Cv low	9.700518pF	-62.91935	10.14983pF

Positive Tol Varactor (High Capacitance)			
Cv high	65.02989pF	-9.385688	92.47168pF
Cv mid	35.60456pF	-17.14248	42.51182pF
Cv low	20.14723pF	-30.2945	22.18712pF

--	--	--	--

	Nominal LO (Nom) Range	Low Tol IF (High) Range	Nominal IF (Nom) Range	High Tol IF (Low) Range
F low	243.77MHz	<b>129.93MHz</b>	121.89MHz	115.03MHz
F mid	261.73MHz	142.59MHz	<b>130.86MHz</b>	121.90MHz
F high	284.18MHz	157.37MHz	142.09MHz	<b>130.98MHz</b>
BW	40.40MHz	27.44MHz	20.20MHz	15.95MHz
% BW	15.44%	19.24%	15.44%	13.09%

Nominal IF Frequency 130.38MHz

Design Constraints			
Condition for bold number	< IF	= IF	> IF
Delta	0.45	-0.48	0.60
Test	pass	pass	pass
Raise or lower cent freq by		-0.48	MHz
Inc or dec BW		-1.05	MHz
Cent adj for min BW		130.46	MHz

K vco 23.77MHz/V

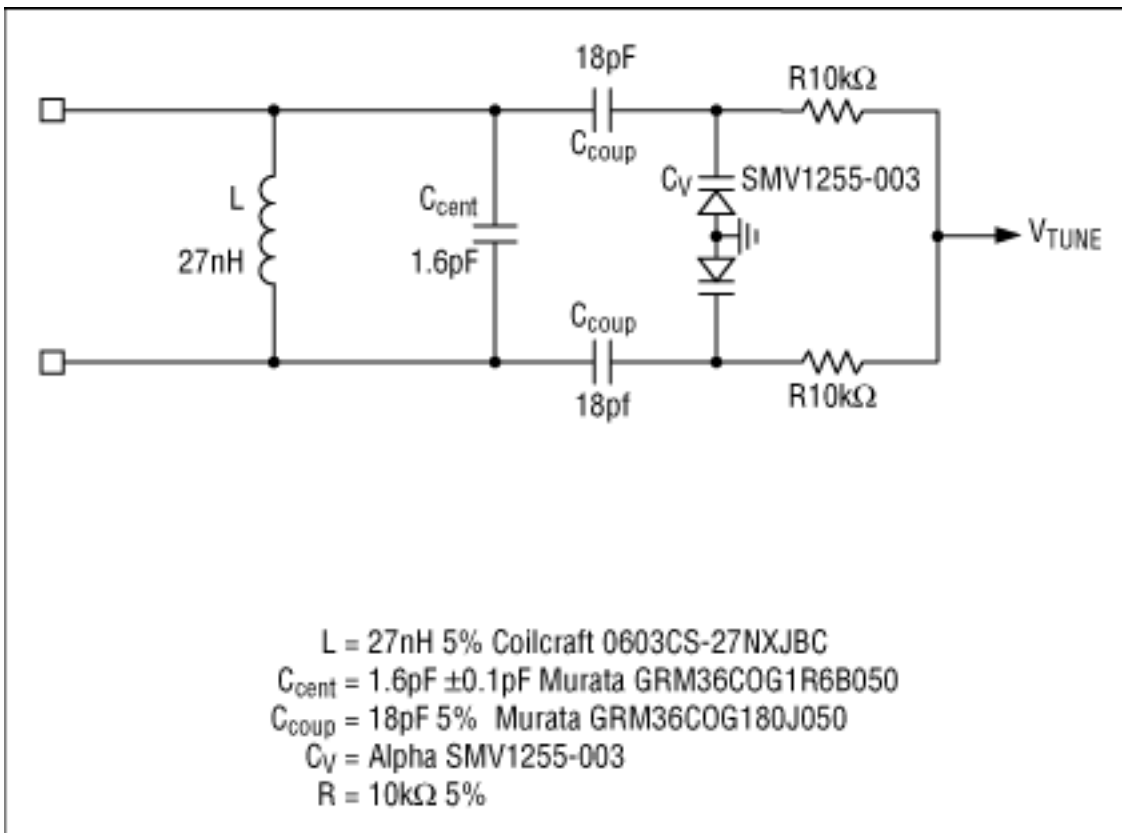

Figure 7. 165MHz IF tank schematic.

Light grey indicates calculated values

Darker grey indicates user input

**Table 2. 165MHz IF Tank Design**

MAX2360 Tank Design and Tuning Range for 165MHz IF Frequency				
Total Tank Capacitance vs. V tune				
V tune	Total C	Ct (Nominal)	Ct (Low)	Ct (High)
0.5V	Ct high	10.0836pF	9.2206pF	10.8998pF
1.375V	Ct mid	8.5232pF	7.3878pF	9.5095pF
2.2V	Ct low	7.0001pF	5.8130pF	8.0193pF

Tank Components	Tolerance		
C coup	18pF	0.9pF	5%
C cent	1.6pF	0.1pF	6%
C stray	0.62pF		
L	27nH	5.00%	
C int	0.34pF	10.00%	

Parasitics and Pads (C stray)		
Due to Q	C L	0.011pF
Ind. pad	C Lp	0.981pF
Due to	C diff	0.118pF
Var. pad	C vp	0.78pF

Varactor Specs			
Alpha SMV1255-003			
Cjo	82pF	Varactor Tolerance	
Vj	17V	0.5V	19.00%
M	14	1.5V	29.00%
Cp	0pF	2.5V	35.00%
Rs	1ohm	Reactance	
Ls	1.7nH	X Ls	3.52
Freq	330.00MHz		

Nominal Varactor	X c	Net Cap
Cv high	54.646968pF	-8.8255163
Cv mid	27.600432pF	-17.473919
Cv low	14.923873pF	-32.316524

Negative Tol Varactor (Low Capacitance)			
Cv high	44.264044pF	-10.895699	65.431921pF
Cv mid	19.596307pF	-24.611153	22.872103pF

Cv low	9.7005176pF	-49.717729	10.440741pF
--------	-------------	------------	-------------

### Positive Tol Varactor (High Capacitance)

Cv high	65.029892pF	-7.4164003	123.93257pF
Cv mid	35.604558pF	-13.545673	48.128632pF
Cv low	20.147229pF	-23.938166	23.626152pF

	Nominal LO (Nom) Range	Low Tol IF (High) Range	Nominal IF (Nom) Range	High Tol IF (Low) Range
F low	305.02MHz	<b>163.63MHz</b>	152.51MHz	143.15MHz
F mid	331.77MHz	182.81MHz	<b>165.88MHz</b>	153.26MHz
F high	366.09MHz	206.08MHz	183.04MHz	<b>166.90MHz</b>
BW	61.07MHz	42.45MHz	30.53MHz	23.74MHz
% BW	18.41%	23.22%	18.41%	15.49%

Nominal IF Frequency	165MHz
----------------------	--------

### Design Constraints

Condition for bold number	< IF	= IF	> IF
Delta	1.37	-0.88	1.90
Test	pass	pass	pass
Raise or lower cent freq by		-0.88	MHz
Inc or dec BW		-3.26	MHz
Cent adj for min BW		165.26	MHz

K vco	35.92MHz/V
-------	------------

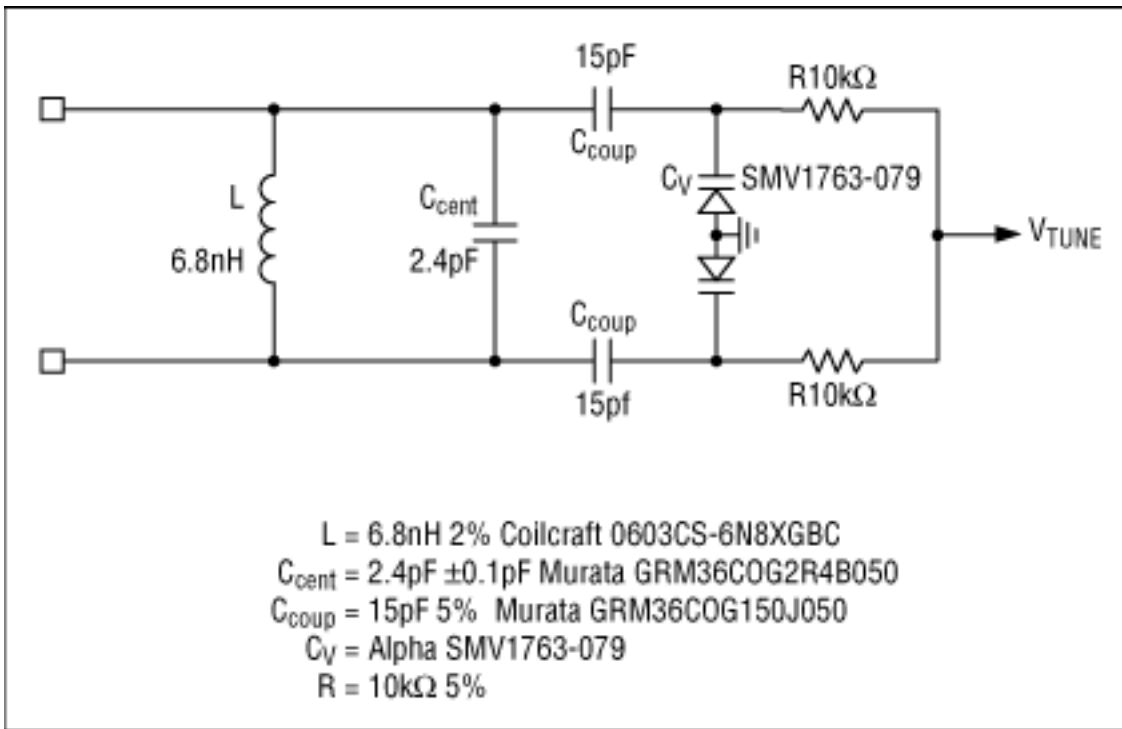

Figure 8. 380MHz IF tank schematic.

- Light grey indicates calculated values
- Darker grey indicates user input

Table 3. 380MHz IF Tank Design

MAX2360 Tank Design and Tuning Range for 380MHz IF Frequency

Total Tank Capacitance vs. V tune				
V tune	Total C	Ct (Nominal)	Ct (Low)	Ct (High)
0.5V	Ct high	6.9389pF	6.6119pF	7.2679pF
1.35V	Ct mid	6.2439pF	5.9440pF	6.5449pF
2.2V	Ct low	5.7813pF	5.5040pF	6.0593pF

Tank Components	Tolerance		
C coup	15pF	0.8pF	5%
C cent	2.4pF	0.1pF	4%
C stray	1.42pF		
L	6.8nH	2.00%	
C int	0.43pF	10.00%	

Parasitics and Pads (C stray)		
Due to Q	C L	0.08pF
Ind. pad	C Lp	0.981pF
Due to	C diff	0.85pF
Var. pad	C vp	0.78pF

**Varactor Specs****Alpha SMV1255-003**

Cjo	8.2pF	<b>Varactor Tolerance</b>	
Vj	15V	0.5V	7.50%
M	9.5	1.5V	9.50%
Cp	0.67pF	2.5V	11.50%
Rs	0.5Ω	<b>Reactance</b>	
Ls	0.8nH	X Ls	3.82
Freq	760.00MHz		

<b>Nominal Varactor</b>		<b>X c</b>	<b>Net Cap</b>
C <sub>V</sub> high	6.67523pF	-31.37186	7.600784pF
C <sub>V</sub> mid	4.286281pF	-48.8569	4.649858pF
C <sub>V</sub> low	2.904398pF	-72.10251	3.06689pF

**Negative Tol Varactor (Low Capacitance)**

C <sub>V</sub> high	6.174588pF	-33.91552	6.958364pF
C <sub>V</sub> mid	3.879084pF	-53.98553	4.174483pF
C <sub>V</sub> low	2.570392pF	-81.47176	2.696846pF

**Positive Tol Varactor (High Capacitance)**

C <sub>V</sub> high	7.175873pF	-29.18313	8.256705pF
C <sub>V</sub> mid	4.693477pF	-44.61818	5.132957pF
C <sub>V</sub> low	3.238404pF	-64.66593	3.441726pF

	<b>Nominal LO (Nom) Range</b>	<b>Low Tol IF (High) Range</b>	<b>Nominal IF (Nom) Range</b>	<b>High Tol IF (Low) Range</b>
F low	732.69MHz	<b>379.11MHz</b>	366.35MHz	354.43MHz
F mid	772.40MHz	399.84MHz	<b>386.20MHz</b>	373.50MHz
F high	802.70MHz	415.51MHz	401.35MHz	<b>388.17MHz</b>
BW	70.00MHz	36.41MHz	35.00MHz	33.74MHz
% BW	9.06%	9.11%	9.06%	9.03%

Nominal IF Frequency	380MHz
----------------------	--------

**Design Constraints**

Condition for bold number	< IF	= IF	> IF
Delta	0.89	-6.20	8.17
Test	pass	pass	pass

Raise or lower cent freq by	-6.20	MHz
Inc or dec BW	-9.07	MHz
Cent adj for min BW	383.64	MHz
K vco	41.18MHz/V	

## Appendix A

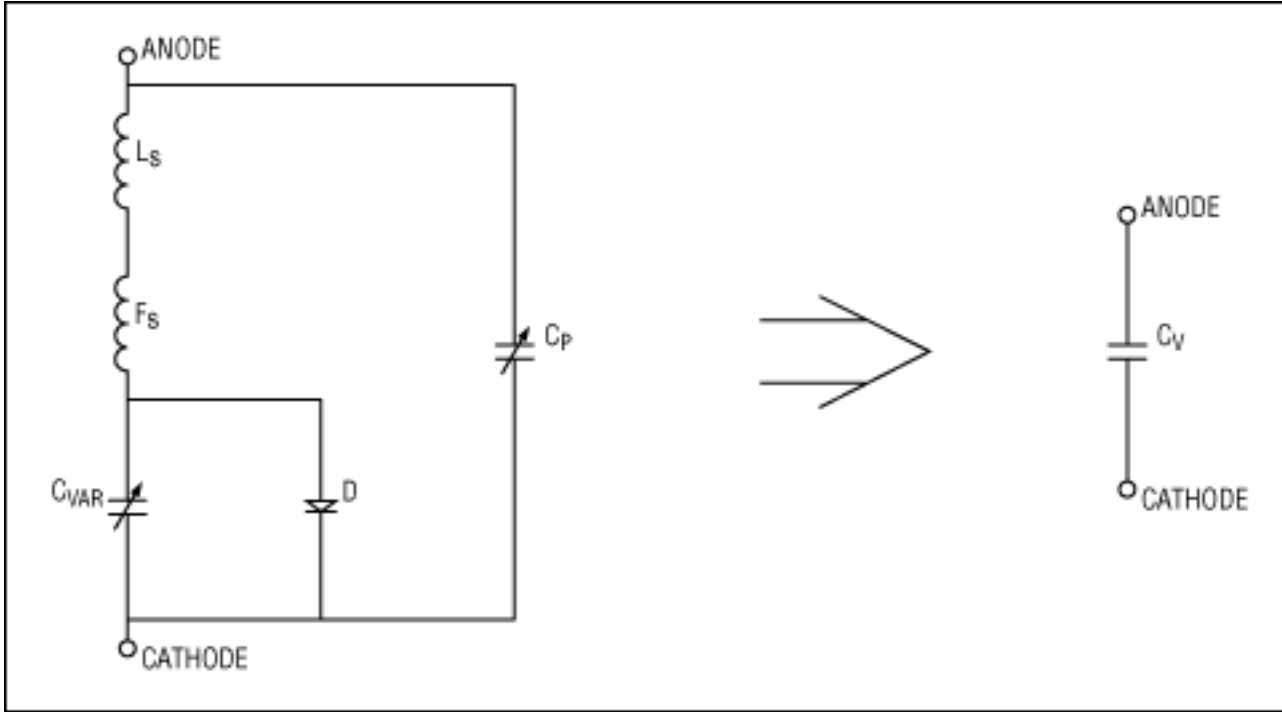

Figure 9. Varactor model.

Alpha Application Note AN1004 has additional information on varactor models. Varactor capacitance is defined in EQN7.

$$C_{VAR} = \frac{C_p}{\left(1 + \frac{V_F}{V_j}\right)^M} + C_p$$

EQN7

Alpha SMV1255-003

$C_{j0} = 82 \text{ pF}$

$V_j = 17 \text{ V}$

$M = 14$

$C_p = 0$

$R_s = 1 \Omega$

$L_s = 1.7 \text{ nH}$

Alpha SMV1763-079

$C_{j0} = 8.2 \text{ pF}$

$V_j = 15 \text{ V}$

$M = 9.5$

$C_p = 0.67$

$R_s = 0.5 \Omega$

$L_s = 0.8 \text{ nH}$

The series inductance of the varactor is taken into account by backing out the inductive reactance and calculating a new effective capacitance  $C_V$ .

$$C_v = -\frac{1}{2\pi f(X_{CVAR} + X_{LS})}$$

EQN8

## References

1. Chris O'Connor, Develop Trimless Voltage-Controlled Oscillators, Microwaves and RF, July 1999.
2. Wes Hayward, Radio Frequency Design, Chapter 7.
3. Krauss, Bostian, Raab, Solid State Radio Engineering, Chapters 2, 3, 5.
4. Alpha Industries Application Note AN1004.
5. Coilcraft, RF Inductors Catalog, March 1998, p.131.
6. Maxim, MAX2360/MAX2362/MAX2364 Data Sheet Rev 0.
7. Maxim, MAX2360 Evaluation Kit Data Sheet Rev 0.

---

Application Note 272: <http://www.maxim-ic.com/an272>

### More Information

For technical questions and support: <http://www.maxim-ic.com/support>

For samples: <http://www.maxim-ic.com/samples>

Other questions and comments: <http://www.maxim-ic.com/contact>

### Related Parts

MAX2360: [QuickView](#) -- [Full \(PDF\) Data Sheet](#)

MAX2361: [QuickView](#) -- [Full \(PDF\) Data Sheet](#)

MAX2362: [QuickView](#) -- [Full \(PDF\) Data Sheet](#)

MAX2363: [QuickView](#) -- [Full \(PDF\) Data Sheet](#)

MAX2364: [QuickView](#) -- [Full \(PDF\) Data Sheet](#)

MAX2365: [QuickView](#) -- [Full \(PDF\) Data Sheet](#)

AN272, AN 272, APP272, Appnote272, Appnote 272

Copyright © by Maxim Integrated Products

Additional legal notices: <http://www.maxim-ic.com/legal>