



APPLICATION NOTE 2696

Redundancy Protection for T3/E3/STS-1 Networks

Abstract: Reliability yields itself to profitability. This is a strong theme that is considered when designing any system; especially in the telecommunications industry where increased competition has caused a greater need to get the most out of the equipment that is purchased. Service providers are demanding that their networking equipment remain active 99.999% of the time, or the 5 nines as it is sometimes called. This is done to not only stay competitive but also to remain profitable. Therefore, the burden has been placed on the networking equipment manufacturers to design new systems that meet or exceed this expectation.

One of the ways to do this is to design systems that have built-in redundancy in the key areas of the design. This concept is not new, but what is new is how you approach this problem with respect to the T3, E3, or STS-1 network interface. In the past, designing redundancy for the network interface was trivial because the port count was relatively low. If redundancy was required, a circuit could switch in and out of the network by a variety of methods. However, as the demand for bandwidth increases, so does the port count as well as the need for redundancy in your design. This article will examine some different types of redundancy protection schemes for a T3/E3/STS-1 network interface while paying particular attention to how this scheme can be implemented with a Maxim T3/E3/STS-1 line interface unit (LIU) or specifically for the DS315x family of parts (DS3151, DS3152, DS3153, and DS3154).

Types of Redundancy Schemes

1:1 Protection

Whether you are designing a network router, WAN access, DSLAM, T/E ATM uplink, or multiplexer, the device will probably need to be functioning for almost the entire life of the product, so using a redundant solution will need to be considered. There are several ways to do this. For small port counts, relays have often been used and can be an effective solution. **Figure 1** shows this type of protection scheme. Please notice, line cards were chosen in the design. If there is a problem with the primary card, you can switch to the protection card to replace the primary card without disrupting service from the network for any significant length of time. Both line cards are identical in this protection scheme. This is important when keeping a replacement card inventory. It is necessary to keep the trace lengths that connect Line Card 1 and Line Card 2 as short as possible to prevent reflections in the transmit signal and thus creating a potential for a pulse mask violation. It is recommended to keep the traces lengths no more than 5 inches from the LIU to the BNC connector.

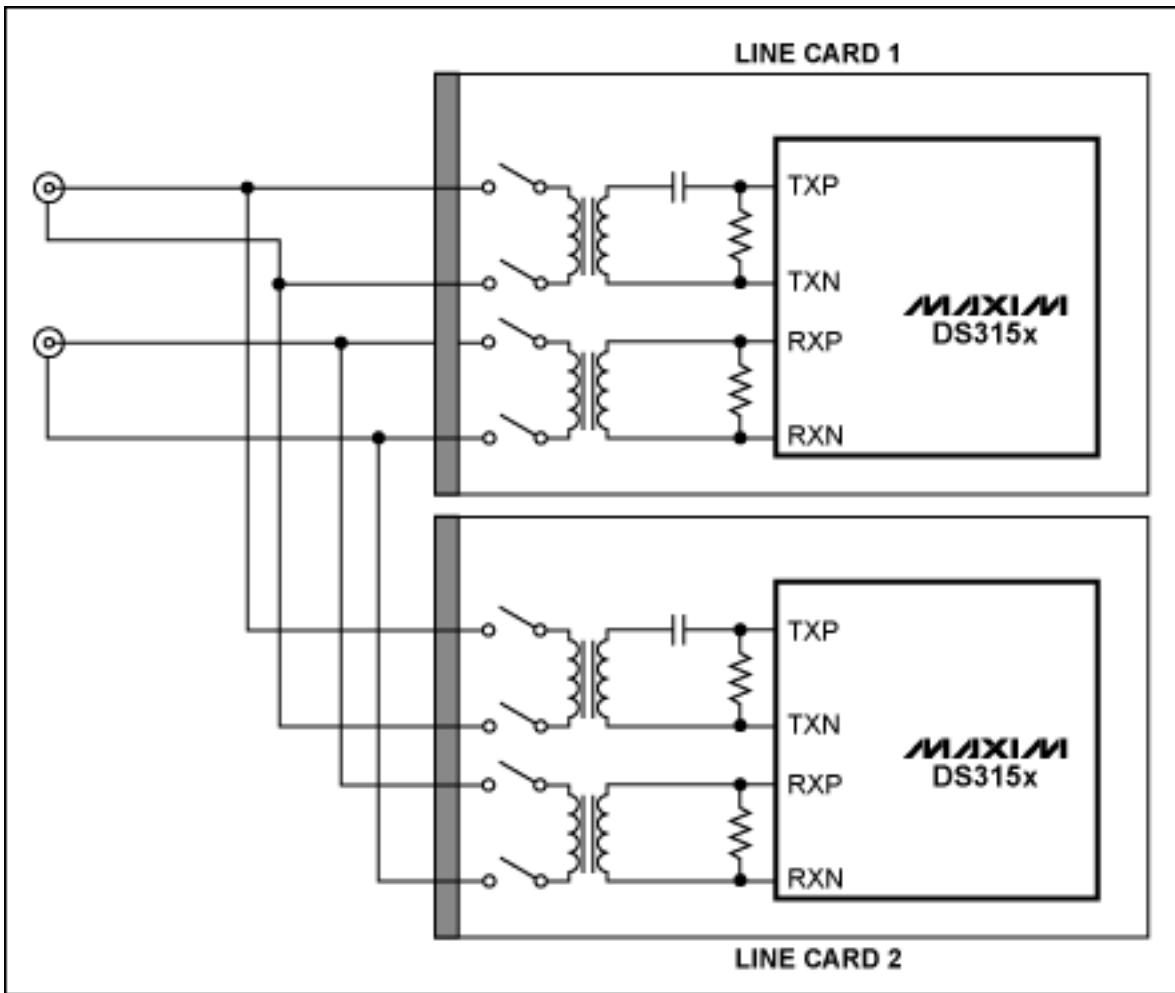

Figure 1.

1:4 Protection

When the number of line cards becomes greater than 2, it becomes much more difficult to efficiently protect the network interface with redundancy. A matrix card may be used to switch out the different line cards to the communication network. Although this method is functional, there is a problem when the matrix card fails. To replace this card, the system needs to be taken offline for either repair or replacement of the card.

Maxim has developed a redundancy scheme that allows the user to swap line cards while still keeping the protection card active. In **Figure 2**, line cards are used for all the active devices, such as the DS315x line interface unit, as well as the relays and local oscillators. In this design, we do not use the matrix card to mux the signals between our primary and protect cards. Instead, we designed a solution using a BALUN network, or Balanced-to-Unbalanced network. This can also be referred to as a power splitter/combiner. A power splitter is a passive device that accepts an input signal and delivers multiple outputs with specific phase and amplitude characteristics. In Figure 2, you can see the power splitter/combiner directly in front of the BNC that is connected to the two separate line cards. One output goes to the primary card for that power splitter while the other is routed to the card below—not to the LIU of the next card. It is routed to what is known as the protect bus. In the event that Line Card N fails, the relay on the protect bus for Line Card N + 1 is closed, and the Protect Card is activated so that data can still be transferred to the T3/E3/STS-1 network. Line Card N that has failed can then be replaced without disrupting service.

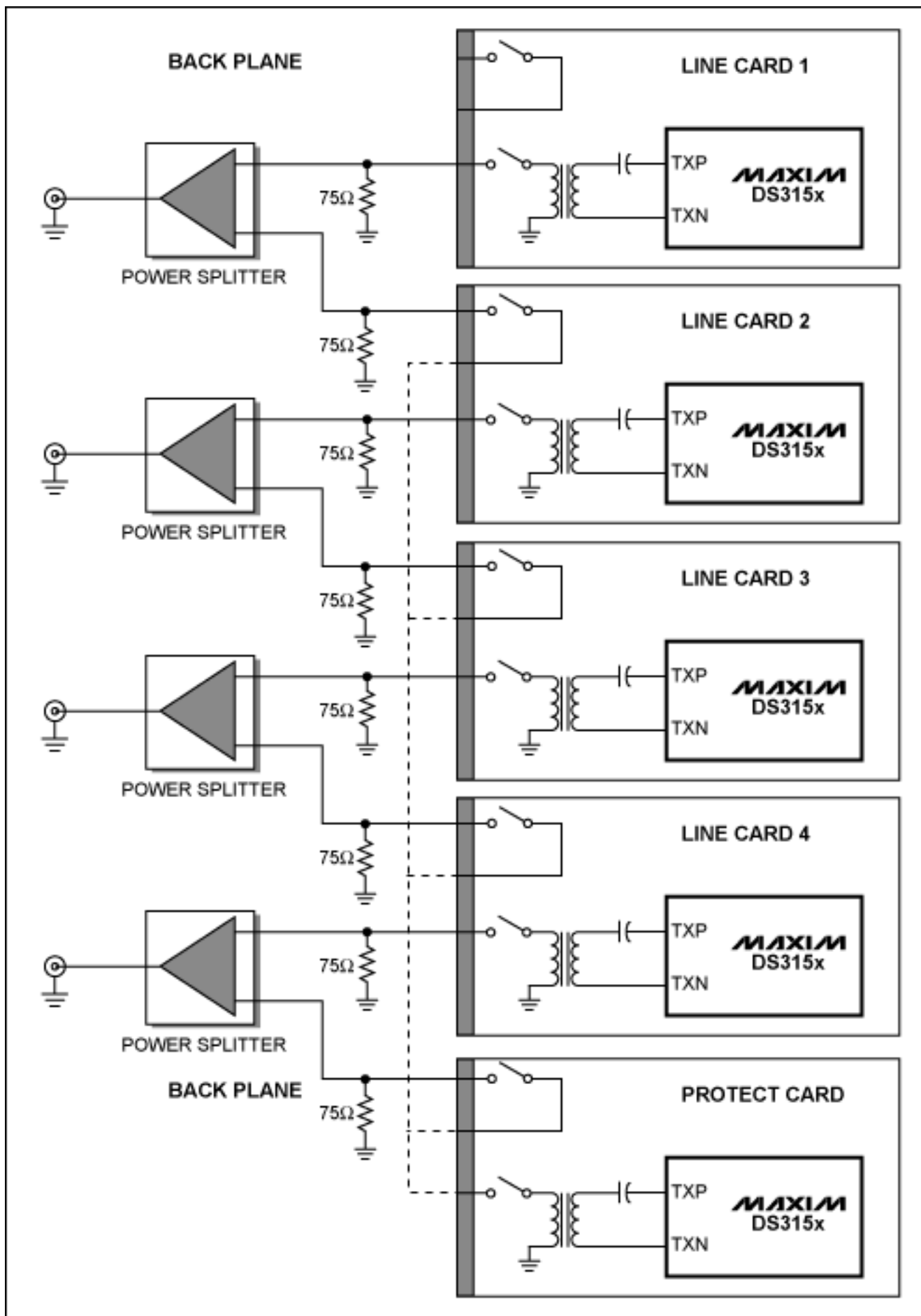

Figure 2.

Power Splitter

With all T3/E3/STS-1 networking applications, the output signals from the power splitter should be of equal amplitude, a 0-degree phase relationship between any two signals, high isolation between each output signal, and a maximum of 3.0dB of insertion loss from the input to the output. Anything greater than 3.0dB may cause problems meeting pulse-mask template, an important requirement in all telecommunication-networking applications.

Figure 3 shows the symbol representation of a common "T" power splitter. Notice that this device is a center-tapped transformer as one input with a resistor connected to the other two ends of the inductor, which serves as the other two outputs or, in some cases, the other two inputs. The resistor across the transformer is key for the functionality of this design. It helps balance the impedance between Port A and Port B, as well as causing the high signal isolation between the two ports from the input in Port C.

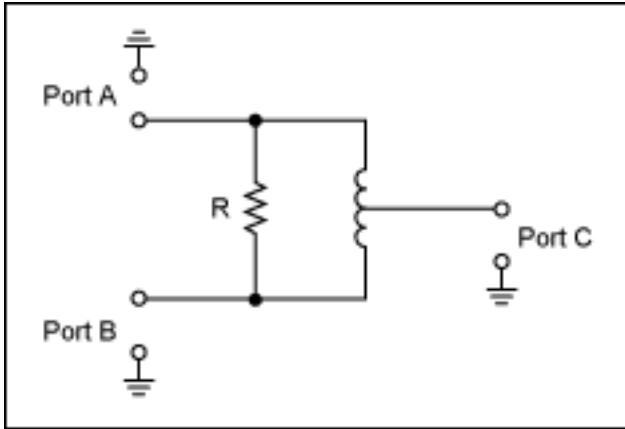

Figure 3.

When the device is used as a power splitter as it is on the Rx or receive side of the LIU, signal isolation is caused by assuming Port A and Port B have exactly the same load. The voltages generated on the ports will have the same amplitude and polarity. Since we have the same voltage on both ports, no current flows through the resistor causing the desired isolation between the two ports. **Figure 4** shows the graphical representation of this circuit. By the symmetry, you can see that I_1 and I_2 are the same. Therefore, the voltage at nodes A and B will be the equal as well.

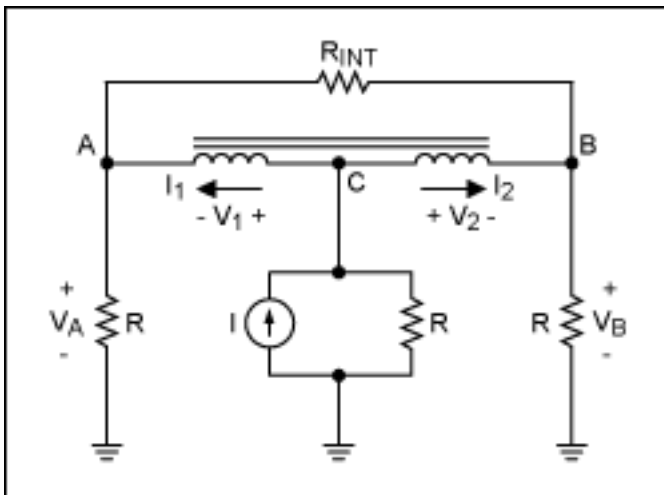

Figure 4.

When you use the device as a power combiner, like it is used on the transmit side of the LIU, there is still high isolation between A and B as there is with the power splitter. A signal applied to Port A causes current to flow through the inductor and creates a 180° phase shift when it reaches Port B. However, there is current flowing through the resistor that is not phase shifted when it reaches Port B. Therefore, if we choose a specific resistance for R_{INT} , we can ensure that the current will be in equal amplitude but opposite in phase to the current from the

inductor. If this is the case, there is no voltage change at Port B, so the high isolation from the two ports is achieved.

For any given T3, E3, or STS-1 network, what would the value of R_{INT} be to cause 100% isolation between Port A and Port B? The power splitter/combiner network is redrawn in **Figure 5**. For this situation, a current is forced at Port B to obtain a specified voltage at Port C. The following equations show how the isolation is obtained with the proper R_{INT} resistor to get 0V at Port A.

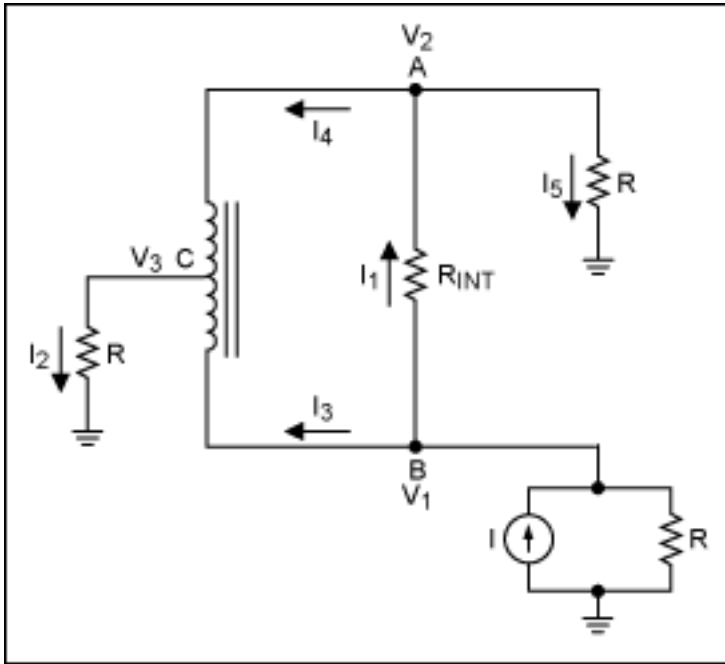

Figure 5.

To simplify the equations, we can assume that V_1 will be 1V, $R = 75\Omega$, and $I_3 = I_4$ due to the fact that the mutual inductance of the transformer is large enough not to cause any leakage current between the two nodes. Therefore, we may derive the following equations.

$$\text{Eq. 1} \quad V_3 = \frac{V_1 + V_2}{2} \quad (V_1 = 1V)$$

$$\text{Eq. 2} \quad I_3 = I_4 = \frac{I_2}{2} \quad (I_2 = I_3 + I_4 \text{ and } I_3 = I_4)$$

$$\text{Eq. 3} \quad I_1 = I_4 + I_5$$

$$\text{Eq. 4} \quad I_5 = \frac{V_2}{R} \quad (R = 75\Omega)$$

$$\text{Eq. 5} \quad I_1 = \frac{V_1 - V_2}{R_{INT}} \quad (V_1 = 1V)$$

$$\text{Eq. 6} \quad I_2 = \frac{V_3}{R} \quad (R = 75\Omega)$$

Solve for R_{INT} in Eq. 5 and replace I_1 with Eq. 3. This result gives Eq. 7.

$$\text{Eq. 7} \quad R_{INT} = \frac{1V - V_2}{I_4 + I_5}$$

Replace I_2 and I_4 with Eq. 2, then Eq. 6 and I_5 with Eq. 4 gives Eq. 8.

$$\text{Eq. 8} \quad R_{\text{INT}} = \frac{1V - V_2}{\frac{V_3}{(75\Omega)} + \frac{V_2}{(75\Omega)}} \cdot \frac{2}{2}$$

Replace V_3 with Eq. 1 to produce Eq. 9.

$$\text{Eq. 9} \quad R_{\text{INT}} = \frac{(75\Omega) \times (4 - 4V_2)}{2 + 5V_2}$$

If we want V_2 to be 0V as stated above, we can solve for R_{INT} to be 150Ω. Any other value for R_{INT} will cause a voltage at V_2 due to the voltage at V_1 . With R_{INT} equal to 150Ω, the desired isolation between the two ports is achieved. Please notice that the voltage at V_3 gets attenuated by a factor of 2 because of Eq. 1. This could cause a problem meeting the Telecom Pulse Mask specs for the networking interface. To overcome the voltage drop at port C (V_3), the DS315x LIU can increase the gain on the transmitter with a test register for each port located at $[n \times (0 \times 10) + (0 \times 8)]$, where n is the port number from 0 to 3.

Figure 6 shows the pulse mask of a DS315x LIU that is connected to the 1 x 4 redundancy-protection scheme, as shown in Figure 3. With the test register enabled, the DS315x LIU can easily generate the voltage required for the E3 pulse mask specification even with the extra load from the power/splitter combiner. Schematics and a BOM listing for this design can be found on the Maxim website at www.maxim-ic.com/telecom.

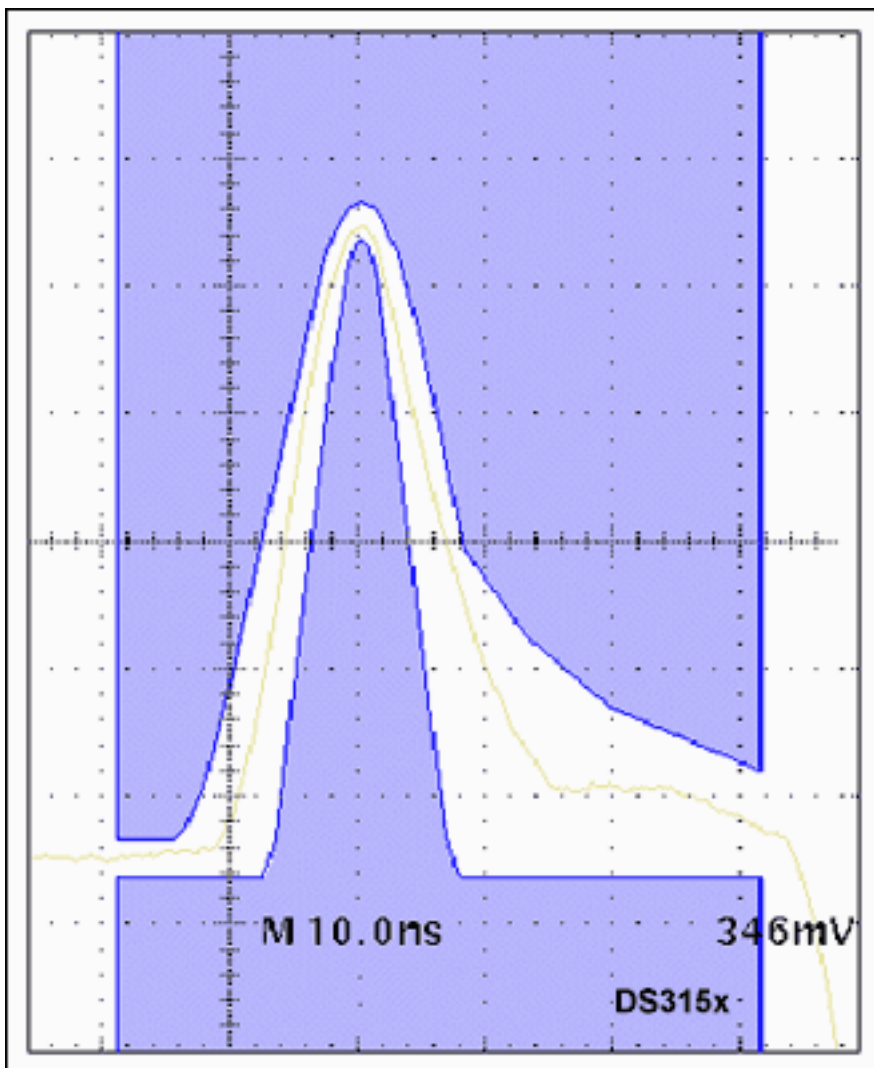

Figure 6.

Conclusion

As the competition increases for IP service providers, the demand will also increase for networking equipment manufacturers to provide solutions that are both highly reliable and cost effective. By using the redundancy scheme with Maxim's DS315x LIU, this objective can be obtained.

Application Note 2696: www.maxim-ic.com/an2696

More Information

For technical support: www.maxim-ic.com/support

For samples: www.maxim-ic.com/samples

Other questions and comments: www.maxim-ic.com/contact

Automatic Updates

Would you like to be automatically notified when new application notes are published in your areas of interest?
[Sign up for EE-Mail.](#)

Related Parts

DS3150: [QuickView](#) -- [Full \(PDF\) Data Sheet](#) -- [Free Samples](#)

DS3151: [QuickView](#) -- [Full \(PDF\) Data Sheet](#) -- [Free Samples](#)

DS3152: [QuickView](#) -- [Full \(PDF\) Data Sheet](#) -- [Free Samples](#)

DS3153: [QuickView](#) -- [Full \(PDF\) Data Sheet](#) -- [Free Samples](#)

DS3154: [QuickView](#) -- [Full \(PDF\) Data Sheet](#) -- [Free Samples](#)

AN2696, AN 2696, APP2696, Appnote2696, Appnote 2696

Copyright © by Maxim Integrated Products

Additional legal notices: www.maxim-ic.com/legal