



Keywords: buck, step-up, boost, step-down, LDO, charge-pump, charge pumps, linear regulators, efficiency, cost, size, noise, ripple, comparison, power supply, portable applications

Aug 01, 2000

APPLICATION NOTE 269

Trading Performance for Cost in Portable Power Supplies

Abstract: A general guide for selecting the optimum power supply architecture in portable applications. A table shows the relative strengths and weaknesses of various architectures when applied to different input-to-output voltage ratios. Each architecture is discussed in further detail in the text.

Higher performance and longer battery life are conflicting expectations that pose a growing challenge for the designers of portable and wireless devices. Price erosion and the need for miniaturization often add to the challenge, forcing a compromise in the solution. Fortunately, the introduction of new power supplies constantly minimizes the trade-off by providing new architectures and better performance.

The parameters most significant in power-supply design are cost, efficiency (battery life), output ripple and noise, and quiescent current. **Table 1** illustrates the trade-off among these parameters for five power-supply architectures and five combinations of V_{IN}/V_{OUT} range. In drawing attention to the strengths and the weaknesses of these architectures, the following discussion also points to some surprising results from the table.

Table 1. Power-Supply Performance vs. Architecture vs. VIN/VOUT Range

	Low Cost	High Efficiency	Low Noise	Low Current
VIN >> VOUT				
LDO Linear	A	D	A	A
Charge Pump Reg.	B	B	C	C
Charge Pump + LDO	C	B	A	D
DC-DC Buck	C	A	C	B
Buck + LDO	D	B	A	C
VIN_{MIN} = VOUT				
LDO Linear	A	B	A	A
DC-DC Buck	C	A	C	B
Buck + LDO	D	C	A	C
Boost + LDO	D	B	B	C
Buck/Boost	D	B	D	C
VIN_{MIN} < VOUT < VIN_{MAX}				
Charge Pump Reg.	B	C	C	C
Charge Pump + LDO	C	D	A	D
Boost + LDO	D	A	B	C
Buck/Boost	D	B	D	C
VIN_{MAX} = VOUT				
Charge Pump Reg.	B	C	C	C
Charge Pump + LDO	C	C	A	D
DC-DC Boost	C	A	D	B
Boost + LDO	D	B	B	C
VIN << VOUT				
Charge Pump Reg.	B	C	C	C
Charge Pump + LDO	C	C	A	D
DC-DC Boost	C	A	D	B
Boost + LDO	D	B	B	C

A = excellent, B = good, C = average, D = poor

Low-Dropout (LDO) Linear Regulators

The LDO's lowest cost, lowest noise, and lowest quiescent current make it a solid choice for many applications. Its external components are minimal: usually a bypass capacitor or two. The newest LDOs offer dramatically improved performance, though of course not all the following are available in the same device: 30 μ Vrms output noise, 60dB PSRR, 6 μ A quiescent current, and 100mV dropout.

Efficiency, though poor when V_{IN} is much larger than V_{OUT} , becomes very high when V_{IN} approaches V_{OUT} . In that case, the LDO benefits are almost impossible to beat. In fact, many circuits converting Li-ion battery voltage to 3V use an LDO, despite having to discard 10% or more of the battery's capacity at the end of discharge. Despite this compromise, LDO circuits for this application offer the longest battery life among low-noise architectures.

Charge Pumps

The basic charge pump offers low cost, requires only a few external capacitors, and is usually approximately 95% efficient. Constant switching action, however, produces output noise and high quiescent current. As another issue, charge pump outputs produce only exact multiples of the input voltage. With, for example, four internal switches and one external flying capacitor, these multiples are limited to +2x, +1/2x, and -1x. Doubling the circuitry makes other multiples available, at the cost of reduced output power or of greater expense and quiescent current. Basic charge pumps seldom connect directly to the battery. Instead, they usually generate secondary voltages from existing regulators.

Charge Pump plus LDO

The charge pump plus LDO architecture avoids the problem of exact voltage multiplication. It also reduces output noise, but at the expense of efficiency. This efficiency loss can be small or large, depending on the relative magnitudes of input and output voltage. As an example, the efficiency for converting a two-cell NiMH battery to 3V output is calculated as follows:

$$Eff. = \frac{3V}{2 \times 2.4V} = 63\%$$

Charge-pump efficiency is not a factor in this expression, because any such efficiency less than 100% causes the charge-pump output to droop, which lowers the input voltage to the LDO and thereby improves the LDO's efficiency.

Charge Pump Regulators

By employing pulse-frequency modulation (PFM) or pulse-width modulation (PWM), the newer charge pump regulators dispense with the need for an LDO. Compared with the charge pump/LDO approach, a regulated charge pump costs less and offers lower quiescent current in the PFM mode, but it has the same efficiency and greater output noise. Some implementations improve efficiency by changing the multiplication factor as needed.

As an example, a conversion from a two-cell alkaline battery to 5V uses +2x multiplication when the batteries are fresh and switches automatically to +3x when the battery voltage falls below 2.5V. In a buck/boost application, another charge pump might start with +1x for buck and switch to +2x for boost. Regulated charge pumps of this sophistication are still relatively rare in the semiconductor industry.

DC-DC Converters

Available in buck, boost, buck/boost, and inverting topologies, DC-DC converters offer high efficiency, high output current, and medium-low quiescent current. On the other hand, they produce output ripple and switching noise. They also are more expensive, thanks to their more complicated control schemes and the need for an external inductor.

In recent years, the push toward submicron chip fabrication has reduced the cost penalties in several ways. First, the lower on-resistance in MOSFETs has, in many applications, eliminated the need for external FETs by enabling higher output power. It's now possible, for example, for a boost converter with 3.6V input and on-chip NFET to produce an output of 2A at 5V. Second, the small die size intended for low-to-medium-power applications allows the use of small and inexpensive packaging. Third, faster switching frequencies (up to 1MHz) have reduced the cost and physical size of external capacitors and inductors. Finally, better control schemes have added valuable features such as soft-start capability, current limiting, and selectable PWM or PFM operation.

DC-DC Buck Converter

In nearly all applications for which V_{IN} is greater than V_{OUT} , the DC-DC buck converter is more efficient than an LDO. This is especially true when V_{IN} is much greater than V_{OUT} , as, for instance, in converting the output of a single Li-ion cell to 1.8V. The DC-DC buck converter exhibits some output ripple and switching noise, but these artifacts are not as severe as in other DC-DC topologies. One notable advance in control schemes is the implementation of duty cycles up to 100%, enabling the circuit to achieve low-dropout performance.

DC-DC Buck Converter with LDO

Combining the DC-DC buck converter with an LDO is useful in applications for which high efficiency and low noise are priorities. This arrangement, however, applies only when V_{IN} is substantially larger than V_{OUT} . If the minimum V_{IN} approaches V_{OUT} , the LDO alone should provide similar efficiency and lower dropout, usually resulting in the same or better battery life for much lower cost.

DC-DC Boost Converter

The most important feature of a DC-DC boost converter is that an LDO cannot perform the same function. The closest competition is the regulated charge pump, which has lower efficiency and lower output power. On the other hand, boost converters have notoriously high output ripple and switching noise. They also require better control schemes, to eliminate oscillation in the output and to reduce efficiency loss due to parasitic resistance in the MOSFET switch and external components.

DC-DC Boost Converter plus LDO

Combining a DC-DC boost converter with an LDO has two advantages: It implements a low-noise boost function (at a slight penalty in efficiency versus the noisy booster without an LDO), and it performs the buck/boost function with surprisingly high efficiency. A typical buck/boost application converts the output of one Li-ion cell to 3.3V. Efficiency is very high, because the battery spends most of its life near 3.6V, allowing the booster to idle and providing the LDO with a near-ideal input voltage. This system also delivers higher efficiency with smaller external components than the traditional SEPIC converter. Because of the favorable characteristics of this arrangement, several single-chip implementations are available for the DC-DC boost converter plus LDO architecture.

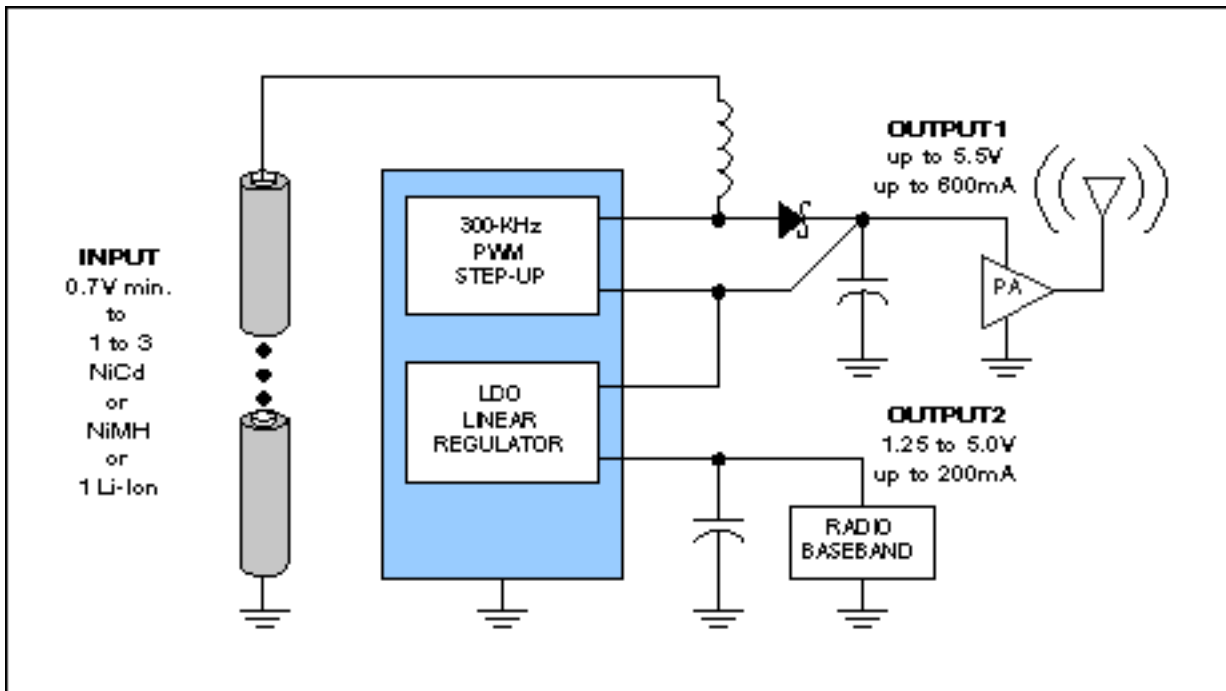

Figure 1. To provide high-efficiency boost and buck/boost outputs on the same chip, the MAX1705 and MAX1706 ICs integrate a PWM step-up DC-DC converter with a low-dropout (LDO) linear regulator. Designed for flexibility, these devices allow operation from a single Li+ cell or from batteries of one, two, or three NiCd, NiMH, or alkaline cells.

DC-DC Buck/Boost H-Bridge Converter

With the potential to provide the highest buck/boost efficiency of all, the DC-DC H-bridge converter deserves further development. It requires only a single inductor, but the H-bridge circuit requires two power-FET switches and two rectifiers. This is twice as many as in a DC-DC buck or boost converter. To date, these extra components and their associated control circuitry have kept the price high. Furthermore, the extra switching loss has limited the efficiency to less than that of the boost-plus-LDO architecture. Nevertheless, further technical developments are likely to improve performance, and this architecture may then become more popular.

A version of this article appeared in *Electronic Products* magazine.

Application Note 269: <http://www.maxim-ic.com/an269>

More Information

For technical questions and support: <http://www.maxim-ic.com/support>

For samples: <http://www.maxim-ic.com/samples>

Other questions and comments: <http://www.maxim-ic.com/contact>

Related Parts

MAX1705: [QuickView](#) -- [Full \(PDF\) Data Sheet](#) -- [Free Samples](#)

AN269, AN 269, APP269, Appnote269, Appnote 269

Copyright © by Maxim Integrated Products

Additional legal notices: <http://www.maxim-ic.com/legal>