

APPLICATION NOTE 266

Split IF Application for Dual-Band Single-Mixer ICs

Abstract: Some dual-band handsets require separate IF frequencies due to IF filtering requirements. When a dual-band LNA/mixer front-end IC with shared mixer IF outputs is used, the split IF paths are generated through the use of switches. This application note show the use of two SPDT switches that choose between the high- or low-band IF SAW filters.

Some dual-band handsets require separate IF frequencies due to IF filtering requirements. When a dual-band LNA/mixer front-end IC with shared mixer IF outputs is used, the split IF paths are generated through the use of switches. **Figure 1** depicts two SPDT switches that choose between the high- or low-band IF SAW filters.

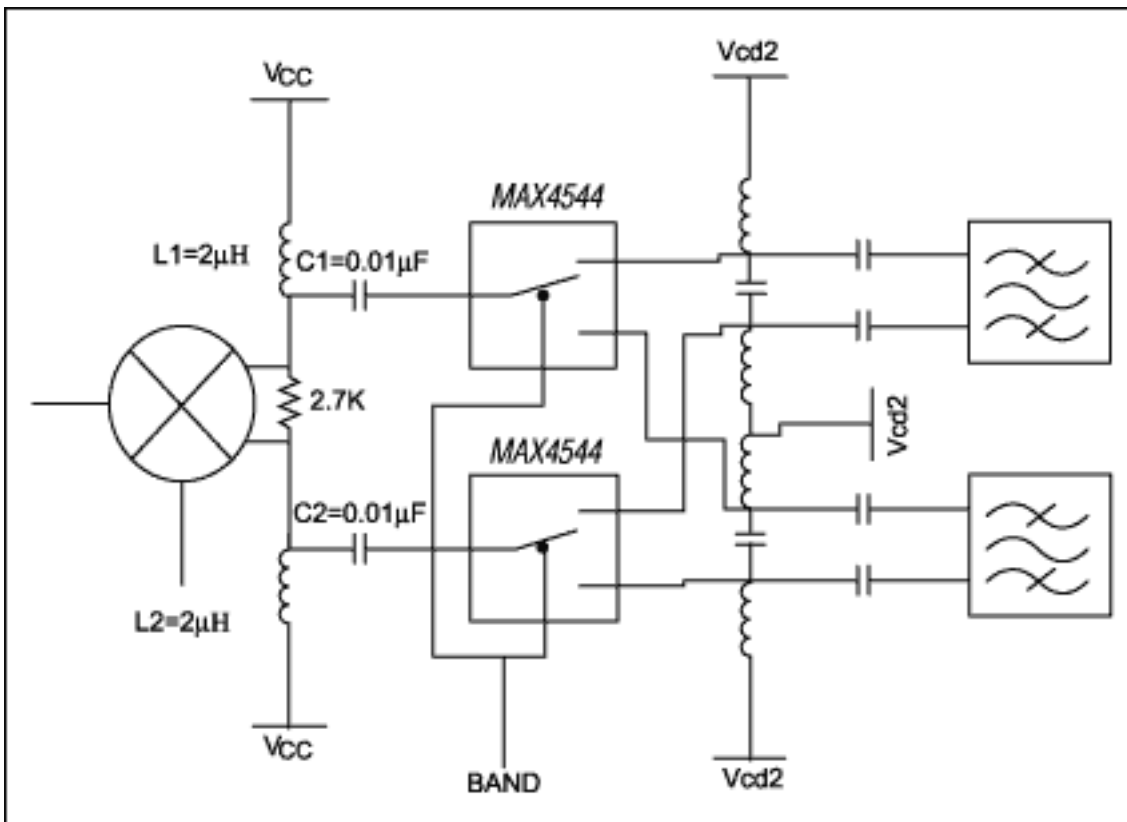

Figure 1. IF switches for dual IF architectures.

The inductors L1 and L2 are chosen large to provide a choke for the mixers. The DC blocking capacitors C1 and C2 prevent current flow to the switch and matching networks, and allow for a DC level at the switch input.

Considerations for the switch include the insertion loss, off-isolation, frequency response, current consumption, package size, and cost. Because IF SAW filters typically are high-impedance devices, the on-resistance of the switch will have minimal impact on the insertion loss (provided it doesn't exceed a few hundred ohms). A typical SPDT switch consumes no more than a few microamps, thus preserving the system's current budget.

The matching networks follow the switch, and they are depicted as a simple LC match that is designed to match the mixer output to the filter input. The shunt inductors can be pulled to Vcc/2 if the DC level needs to be set for maximum dynamic range. If the switch is internally biased, then the inductors can be shunted to GND. In this scenario, DC blocking capacitors will be required between the switch and the matching network.

In applications where the shunt inductors for the two IF frequencies are the same, they can be implemented in place of the chokes L1 and L2, thus eliminating four inductors from the design.

Application Note 266: <http://www.maxim-ic.com/an266>

More Information

For technical questions and support: <http://www.maxim-ic.com/support>

For samples: <http://www.maxim-ic.com/samples>

Other questions and comments: <http://www.maxim-ic.com/contact>

Related Parts

MAX4544: [QuickView](#) -- [Full \(PDF\) Data Sheet](#) -- [Free Samples](#)

AN266, AN 266, APP266, Appnote266, Appnote 266

Copyright © by Maxim Integrated Products

Additional legal notices: <http://www.maxim-ic.com/legal>