

## APPLICATION NOTE 261

## Calibration-Multiplexers Ease System Calibration

*Abstract: IC switches and multiplexers are proliferating, thanks to near-continual progress in lowering the supply voltage, incorporating fault-protected inputs, clamping the output voltage, and reducing the switch resistances. The latest of these advances is the inclusion of precision resistors to allow two-point calibration of gain and offset in precision data-acquisition systems.*

Called calibration multiplexers (cal-muxes), these new devices are exemplified by a low-voltage, 8-channel CMOS multiplexer (MAX4539). It has internal precision resistive dividers that generate accurate voltage ratios, either from an external reference or from its own supply voltage. By eliminating the need for external resistor strings, multiplexers, and logic gates, the MAX4539 provides an accurate and convenient means for calibrating and monitoring A/D converters.

The MAX4539 operates from a single supply of 2.7V to 12V or a dual supply in the range  $\pm 2.7V$  to  $\pm 6V$ . Switch on-resistances measure 100ohm, matched to within 6ohm maximum. They handle rail-to-rail analog signals and exhibit off leakages of only 0.1nA over the industrial temperature range. Package options include a 20-pin SO, a 20-pin DIP, and the small 20-pin SSOP.

The internal resistors are accessed and configured via a versatile digital interface that includes a 3-bit address, enable input, calibration input, and latch input. In turn, these inputs drive an internal, 16-output logic decoder that controls both the main multiplexer and the switches that configure a calibration.

The MAX4539 turns on when ENABLE is high and behaves as a conventional multiplexer unless the CAL input is asserted. With CAL and ENABLE both asserted, the three address inputs (via the logic decoder) select one of the resistor-divider or external-reference outputs. The LATCH function lets the chip capture this state, thereby releasing the address bus.

Two main features set the cal-mux apart. One is the LATCH function, and the other is its capability for calibration and self-monitoring. Four internal resistor dividers give access to four fixed ratios:  $(15/4096)(V_{REFHI} - V_{REFLO})$  and  $(4081/4096)(V_{REFHI} - V_{REFLO})$  (where  $V_{REF}$  is the external reference),  $(5/8)(V^+ - V^-)$ , and  $(1/2)(V^+ - V_{GND})$ . In addition to these quantities, the MAX4539 gives individual access to GND, REFHI, and REFLO. The use of precision internal resistors with excellent thermal tracking results in a calibration procedure with accuracies better than 15 bits ( $0.1/4096$ ) over the industrial temperature range.

Each address gives a different configuration of the multiplexer and calibration switches. Driving the LATCH input high captures a given control state, enabling the device to ignore perturbations on the address lines until LATCH returns low.

The MAX4539 is very useful in multi-input industrial control systems that employ A/D converters (**Figure 1**). By generating reference voltages that are converted by the ADC and recorded by the microcontroller, it can null the two major errors associated with ADC systems (offset error and gain error). **Figure 2** illustrates the operating sequence for such a procedure in a single-supply system.

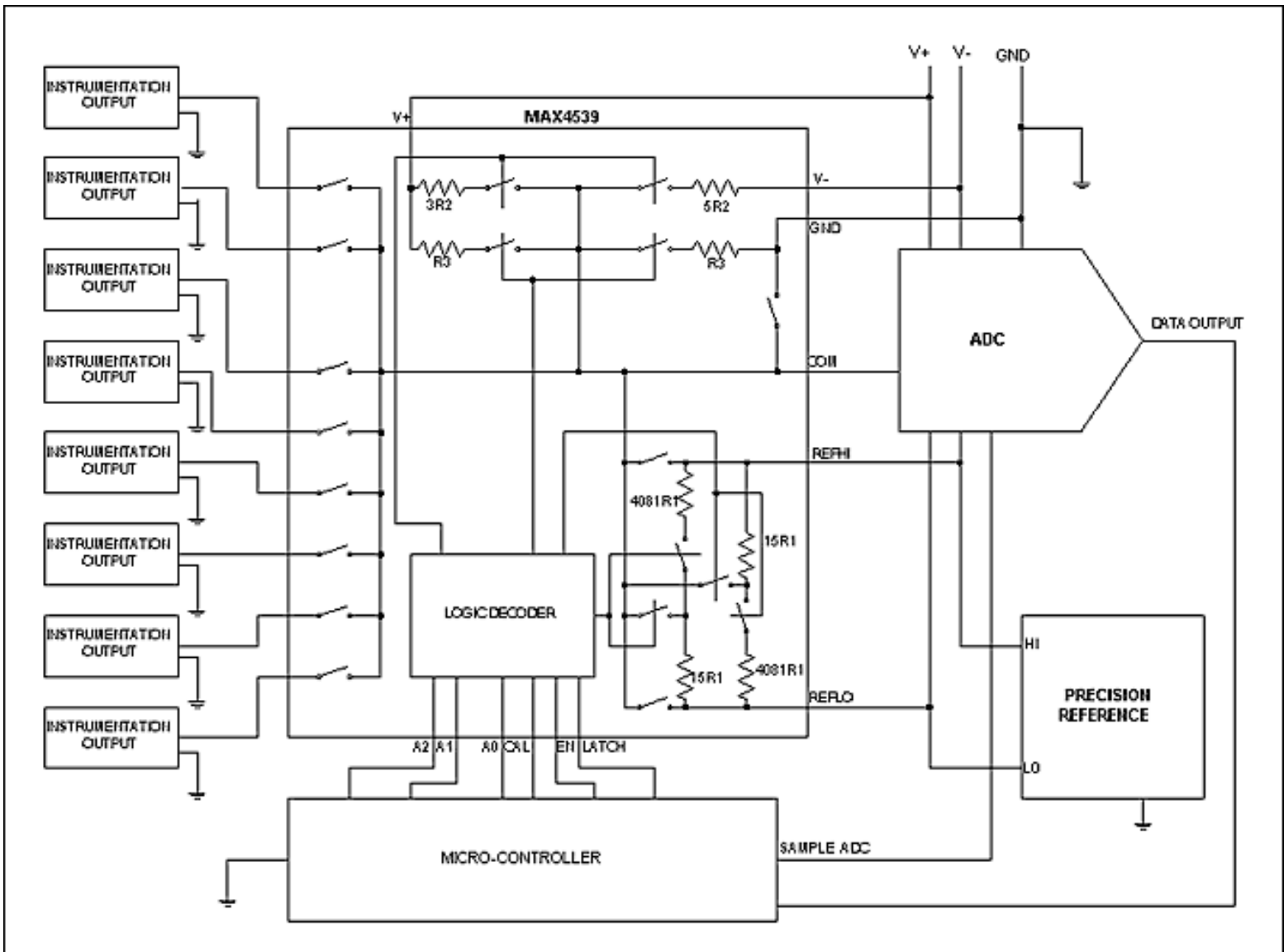

Figure 1. The MAX4539 cal-mux simplifies calibration of a multi-channel industrial control system.

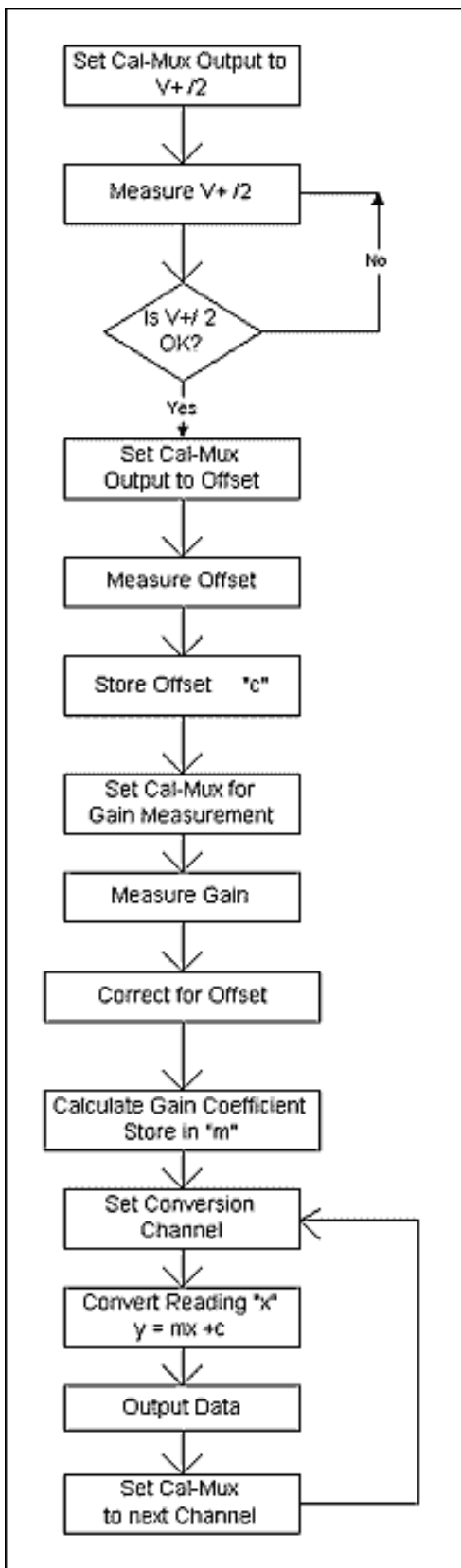

Figure 2. This flow chart details a calibration procedure implemented in the Figure 1 system.

First, the cal-mux applies one-half the supply voltage as a first verification that proper power is applied. The system then measures zero offset and gain error, and forms an equation to correct the subsequent readings. To calibrate for offset error--the input voltage (ideally zero) necessary to produce an all-zero digital output--the cal-mux applies  $(15/4096)(V_{REFHI} - V_{REFLO})$ . Using a 12-bit ADC with 4.096V reference as an example,  $(15/4096)(V_{REFHI} - V_{REFLO})$  equals 15mV and also 15LSBs. The digital output should therefore be 000000001111. To measure offset error, the microcontroller simply records the difference between the ADC's digital output and 000000001111.

Gain error is measured by applying  $(4081/4096)(V_{REFHI} - V_{REFLO})$ . The microcontroller then records the difference between the

ADC's digital output and 11111110000. Knowing the ADC's offset error and gain error, system software constructs calibration factors that adjust the subsequent outputs to produce correct readings.

Finally, the cal-mux monitors the system power supply by generating proportional voltages that are easily converted by the ADC and measured by the microcontroller:  $(1/2)(V^+ - V_{\text{GND}})$  for single-supply systems, and  $(5/8)(V^+ - V^-)$  for dual-supply systems.

---

Application Note 261: <http://www.maxim-ic.com/an261>

#### **More Information**

For technical questions and support: <http://www.maxim-ic.com/support>

For samples: <http://www.maxim-ic.com/samples>

Other questions and comments: <http://www.maxim-ic.com/contact>

#### **Related Parts**

MAX4539: [QuickView](#) -- [Full \(PDF\) Data Sheet](#) -- [Free Samples](#)

AN261, AN 261, APP261, Appnote261, Appnote 261

Copyright © by Maxim Integrated Products

Additional legal notices: <http://www.maxim-ic.com/legal>