

APPLICATION NOTE 256

Two AA Cells Power Step-Down Regulator and 3.3V Boost

Abstract: Stepping down from low voltage inputs like 2 AA cells is challenging. This circuit provides one solution to generate 1.5V at 600mA and also supplies 3.3V at 200mA.

DC-DC conversion is particularly challenging when both the input and output voltages are low. Step-up ICs that operate from less than +1V are available, but step-down ICs that accept input voltages near +2V are not. Thus, providing efficient power for the low-voltage CPU core in a hand-held product can be a problem if the power source is a 2-cell AA battery. This battery output can drop to 1.8V as the battery discharges.

The upper switch-mode DC-DC converter in **Figure 1** (IC1) generates over 600mA at 1.5V, from a 2-AA-cell input that varies from +3.4V to +1.8V. The 3.3V rail that powers this step-down controller is taken from a high-current, synchronous-rectified boost controller (IC3), which is otherwise included to provide power for external logic and the CPU's I/O blocks. Note that IC1 is biased by 3.3V, but power for the 1.5V output comes directly from the battery.

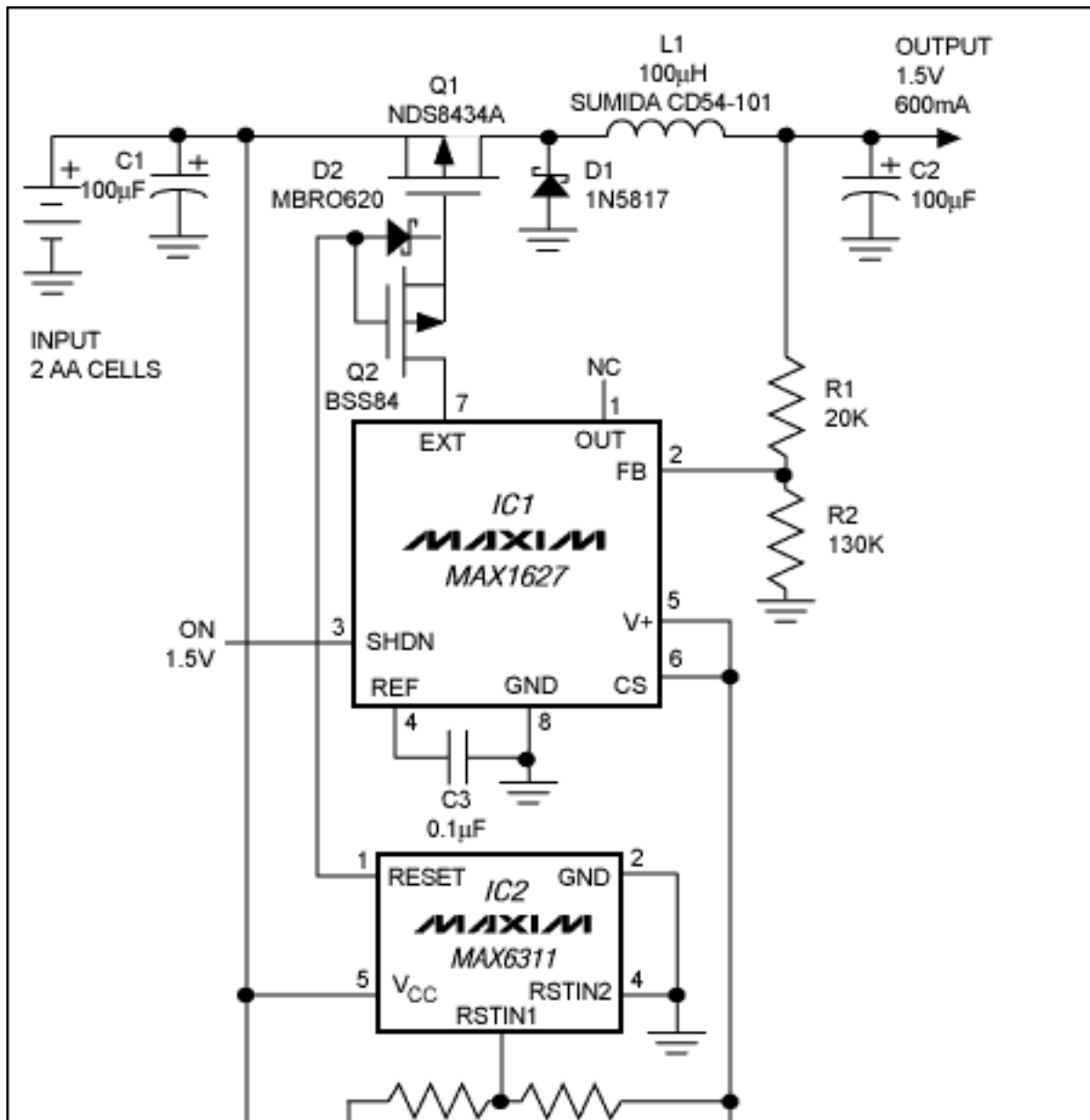

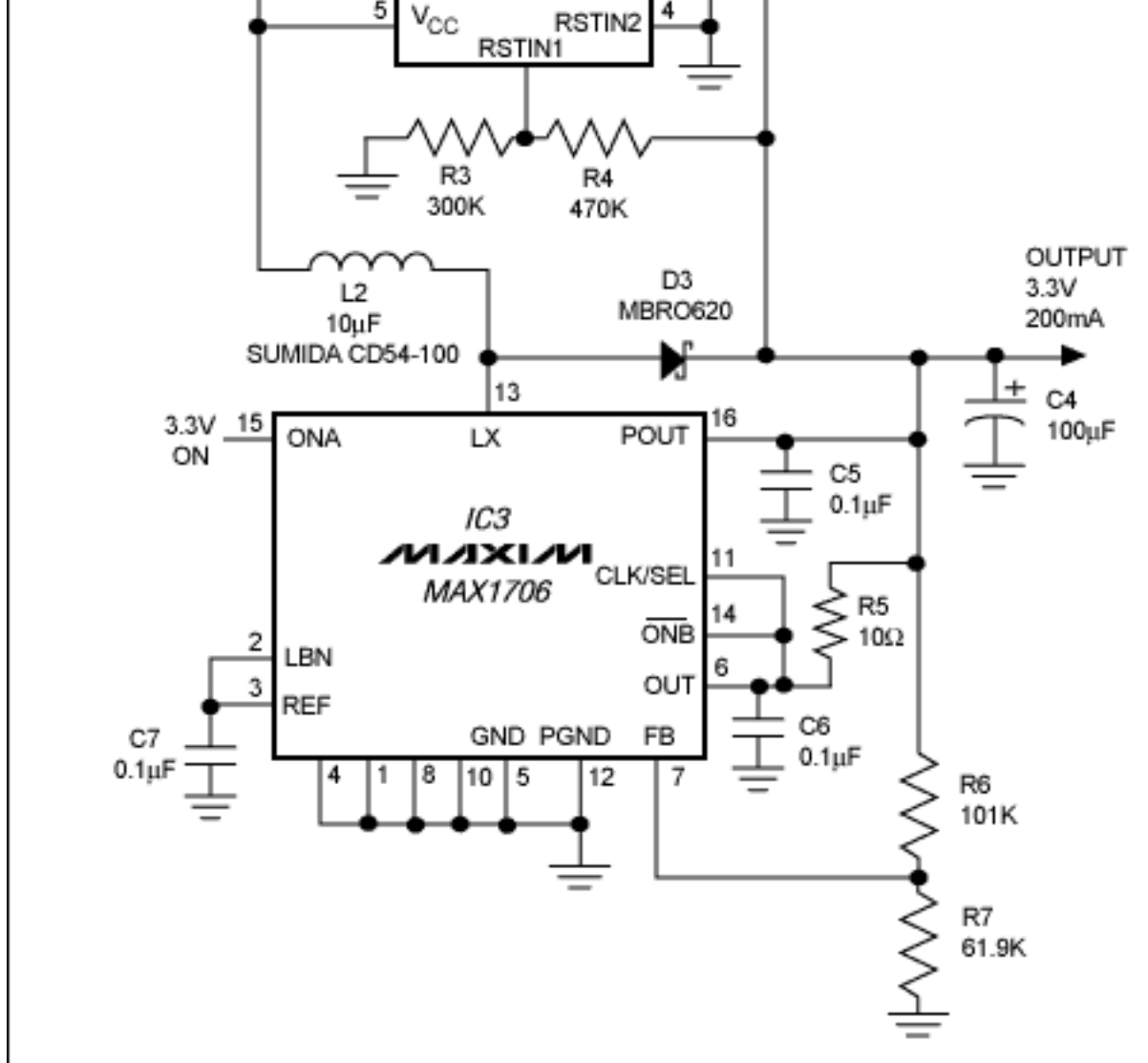

Figure 1. Powered by the 3.3V boost controller IC3, this step-down controller (IC1) generates 1.5V from inputs as low as 1.8V. If the 3.3V rail dips below the allowed minimum, IC2 and Q2 shut down the circuit by turning off Q1.

When the 3.3V rail is too low to properly operate IC1, the switching power MOSFET (Q1) is forced off by Q2, D2, and a SOT23 reset (IC2). Without these components, the conditions at power-up (battery voltage present but 3.3V momentarily absent, pulling the Q1 gate low) may cause the 1.5V output to overshoot to the battery voltage.

The 1.5V output's buck-conversion efficiency (about 85%) is quite good for the circuit's extra-small components: a 3-pin SOT23 power MOSFET (Q1) and 5mm-diameter surface-mount inductors. For the 3.3V output, IC3's on-chip synchronous rectification yields a boost efficiency higher than 90%.

A similar idea appeared in the 1/7/99 issue of EDN.

Application Note 256: <http://www.maxim-ic.com/an256>

More Information

For technical questions and support: <http://www.maxim-ic.com/support>

For samples: <http://www.maxim-ic.com/samples>

Other questions and comments: <http://www.maxim-ic.com/contact>

Related Parts

MAX1627: [QuickView](#) -- [Full \(PDF\) Data Sheet](#) -- [Free Samples](#)

MAX1706: [QuickView](#) -- [Full \(PDF\) Data Sheet](#) -- [Free Samples](#)

MAX6311: [QuickView](#) -- [Full \(PDF\) Data Sheet](#) -- [Free Samples](#)

AN256, AN 256, APP256, Appnote256, Appnote 256

Copyright © by Maxim Integrated Products

Additional legal notices: <http://www.maxim-ic.com/legal>