



Keywords: laser diode, MAX3667, power consumption, power supply requirements, laser transmitter, jitter, optical transmission, SDH/SONET, current requirements, switching capability, laser lead inductances, laser driver, 622Mbps

Dec 03, 1998

APPLICATION NOTE 242

MAX3667: Driving A Laser Diode With the MAX3667 From A Single +3.3V Power Supply

Abstract: As fiber communication systems continue to move into the home, equipment manufacturers are being driven more than ever to reduce power consumption. Reducing the power supply requirements into a single +3.3V supply is one obvious way to significantly improve the overall power dissipation of any system. But finding a fiber optic transmitter that operates properly in a single +3.3V environment, while still meeting the stringent jitter and optical transmission requirements typical of SDH/SONET telecommunications, is a difficult challenge. High current requirements, fast switching capability, and laser diode lead inductance all work against achieving the +3.3V goal. Maxim's new MAX3667 laser driver, part of Maxim's complete +3.3V, 622Mbps fiber communication solutions, overcomes these challenges and provides a unique solution.

As fiber communication systems continue to move into the home, equipment manufacturers are being driven more than ever to reduce power consumption. Reducing the power supply requirements into a single +3.3V supply is one obvious way to significantly improve the overall power dissipation of any system. But finding a laser transmitter that operates properly in a single +3.3V environment, while still meeting the stringent jitter and optical transmission requirements typical of SDH/SONET telecommunications, is a difficult challenge.

High current requirements, fast switching capability, and laser lead inductances all work against achieving the +3.3V goal. Maxim's new MAX3667 laser driver, part of Maxim's complete +3.3V, 622Mbps fiber communication solutions (**Figure 1**), overcomes these challenges and provides a unique solution.

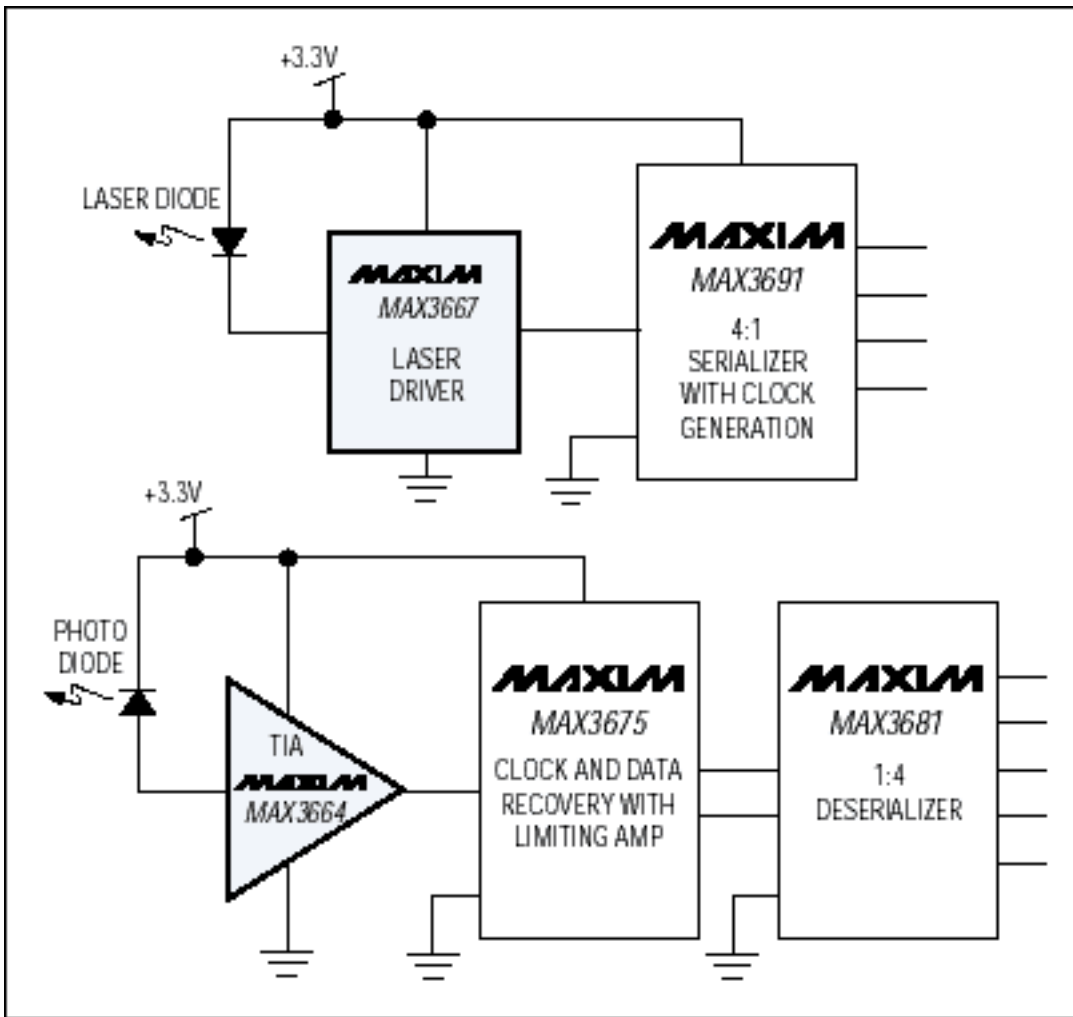

Figure 1. Maxim's +3.3V, 622Mbps chipset.

The operating temperature range for telecommunications covers -40°C to $+85^{\circ}\text{C}$. Over this range, the required threshold current for laser diodes will vary significantly. It is not uncommon for the laser's threshold level to move by more than 40mA between -40°C and $+85^{\circ}\text{C}$ (**Figure 2**).

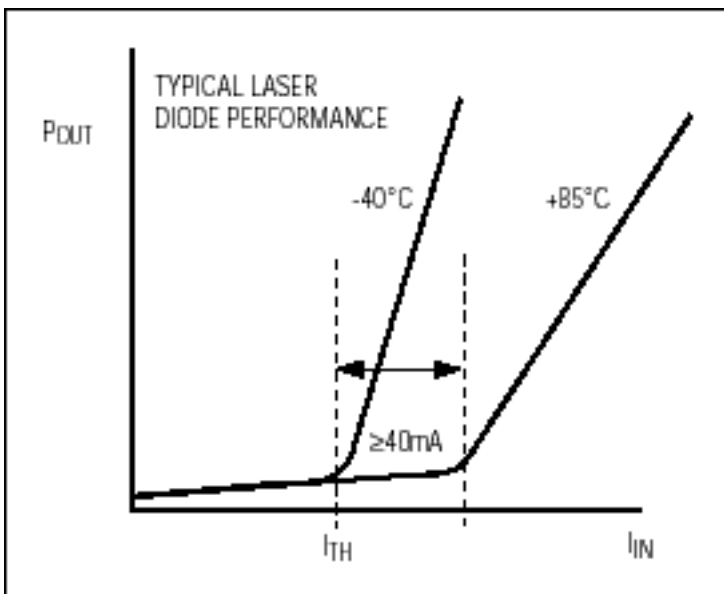

Figure 2. Laser diode threshold vs. temperature.

Typical long-wavelength, Fabry-Perot-style laser diodes require forward bias voltages on the order of 1.2V. This forward bias requirement is a function of the energy gap associated with the laser diode and can be greater than 1.6V. The forward voltage drop, together with a $+3.3\text{V} \pm 5\%$ supply, means as little as 1.5V could be all that

remains for the laser driver output stage. Within this tight constraint, the laser driver must provide both a bias current (I_{BIAS}) to set the laser diode above threshold and a modulation current (I_{MOD}) to transmit the data. Bias current requirements as high as 60mA are typical and, depending on the distance requirements, modulation currents could exceed 60mA. At the same time, the output signal must be fast enough to meet the stringent jitter generation requirements as well as the transmission eye diagram of SDH/SONET.

Figure 3 shows a laser diode and the inductance associated with the package. In this configuration, a total current of $I_{BIAS} + I_{MOD}$ must flow through both the laser diode and the inductance.

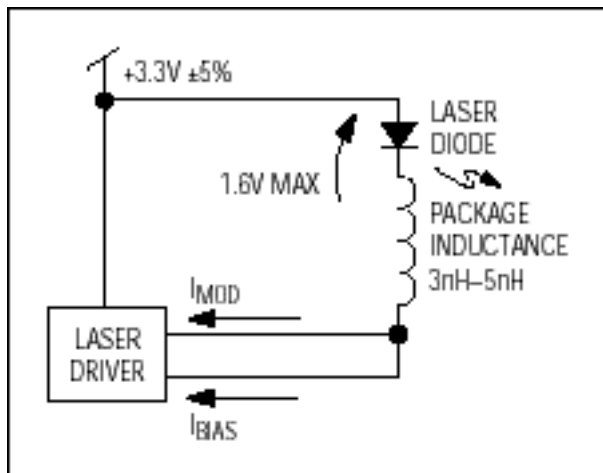

Figure 3. DC-coupled laser.

The total voltage drop at the output of the laser driver is $1.6V + L\Delta i/\Delta t$. For 622Mbps applications, optical edge speeds of less than 600ps (electrical) are typical, resulting in an additional voltage transient across the inductor as high as:

$$V_L = 5nH (60mA) / 600ps = 500mV$$

This results in an output voltage requirement for the laser driver of $+3.1V - 1.6V - 0.5V = 1.0V$.

The traditional bias current output stage is a simple current source capable of operating within such a tight operating voltage. On the other hand, the modulation current output stage is typically a switching differential pair, requiring more than two V_{BE} (base emitter voltage) of headroom and making it impossible to operate with such low output voltage requirements. The MAX3667 incorporates a high-speed current source architecture capable of operating within the reduced headroom (**Figure 4**).

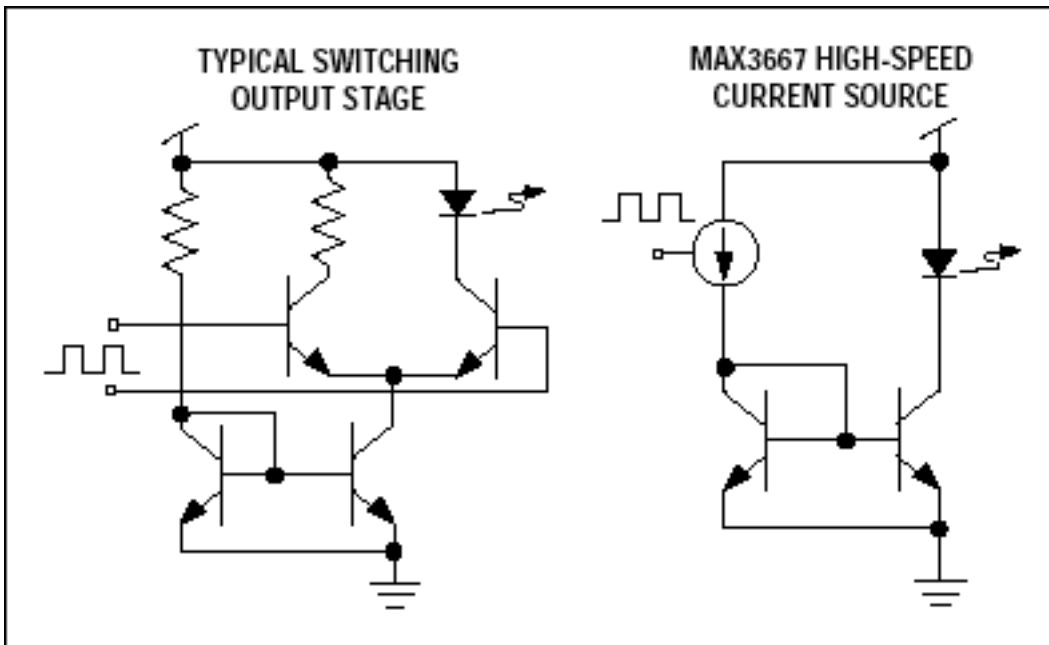

Figure 4. Different laser driver output stages.

By isolating the output stage from the DC voltage drop associated with the laser diode, the I_{MOD} output can operate closer to the supply voltage and thus further relax the headroom constraints (**Figure 5**).

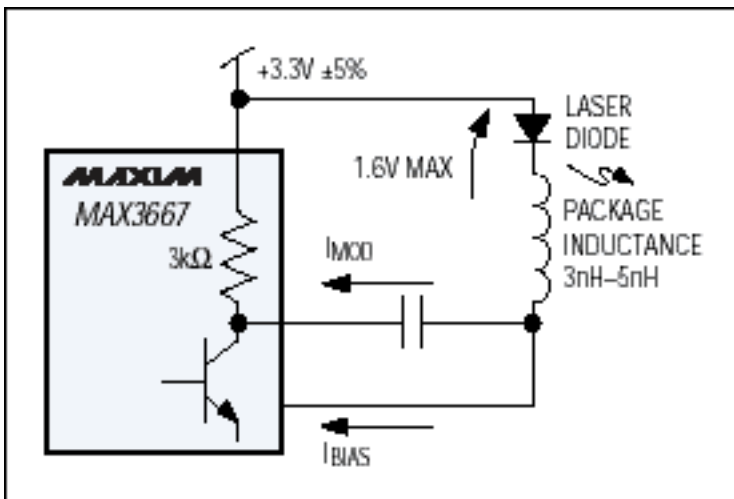

Figure 5. AC-coupled modulation current.

Maxim's MAX3667 laser driver allows AC-coupling of the I_{MOD} output by providing an integrated pull-up resistor for self-biasing and enough current drive capability to overcome the additional loading of such a technique. The total modulation current available at the output of the MAX3667 actually exceeds 100mA_{p-p}. The internal pull-up resistor of 31Ω, as well as the damping and matching resistors expected when interfacing to laser diodes at high speeds, results in a reduction of the total modulation current made available at the laser diode. For typical resistor values, this current is divided down to approximately 60mA_{p-p}.

There are trade-offs to AC-coupling the modulation current. By introducing a capacitor into the signal path, a low-frequency cutoff has been added to the system. SDH/SONET signals consist of non-return-to-zero data streams. Typical expectations for these systems are that they will maintain a 10^{-10} bit error rate with up to 72 consecutive 1s or 0s. This low frequency requirement, together with the time constant associated with the DC-blocking capacitor, can greatly affect the pattern-dependent jitter (PDJ) at the output of the laser diode. It is important that this time constant result in minimum output droop associated with the long consecutive bit streams. Obviously, this problem can easily be solved by using a large capacitor for the coupling capacitor, but this works against the typical design goal of reducing the size of the optical transmitter. By using an ACcoupling capacitor no bigger than 1μF, the MAX3667 can achieve low output droop and low PDJ for consecutive bit streams greater than 100 bits.

The MAX3667 can operate a laser diode from a single +3.3V supply. In addition to providing enough drive capability, it contains a fully integrated APC loop for maintaining the bias current over temperature. The MAX3667 easily meets ITU and Bellcore jitter generation specifications for 622Mbps transmitters, without increasing cost or layout complexity.

Application Note 242: <http://www.maxim-ic.com/an242>

More Information

For technical questions and support: <http://www.maxim-ic.com/support>

For samples: <http://www.maxim-ic.com/samples>

Other questions and comments: <http://www.maxim-ic.com/contact>

Related Parts

MAX3667: [QuickView](#) -- [Full \(PDF\) Data Sheet](#) -- [Free Samples](#)

AN242, AN 242, APP242, Appnote242, Appnote 242

Copyright © by Maxim Integrated Products

Additional legal notices: <http://www.maxim-ic.com/legal>