

APPLICATION NOTE 2416

# DS27xx Fuel Gauge Board Layout Techniques to Minimize Measurement Error

The DS27xx family of Dallas Semiconductor fuel gauge devices is designed to measure with extreme accuracy the current flowing into and out of a battery. However, the level of accuracy can be diminished when using an external sense resistor if the component layout is not carefully considered. This application note describes to the reader several board layout techniques which should be considered when designing a circuit board using a Dallas Semiconductor fuel gauge device with an external sense resistor. It discusses both the sources of possible error and how to diminish their effect through various layout techniques.

## Introduction

Dallas Semiconductor fuel gauges provide an extremely accurate method for measuring and accumulating current flow through an application. The measurement technique accuracy relies on properly measuring the voltage drop across an external sense resistor. As this application note describes, resistor placement and trace routing are very important to achieving accuracy goals.

## Sources of Error

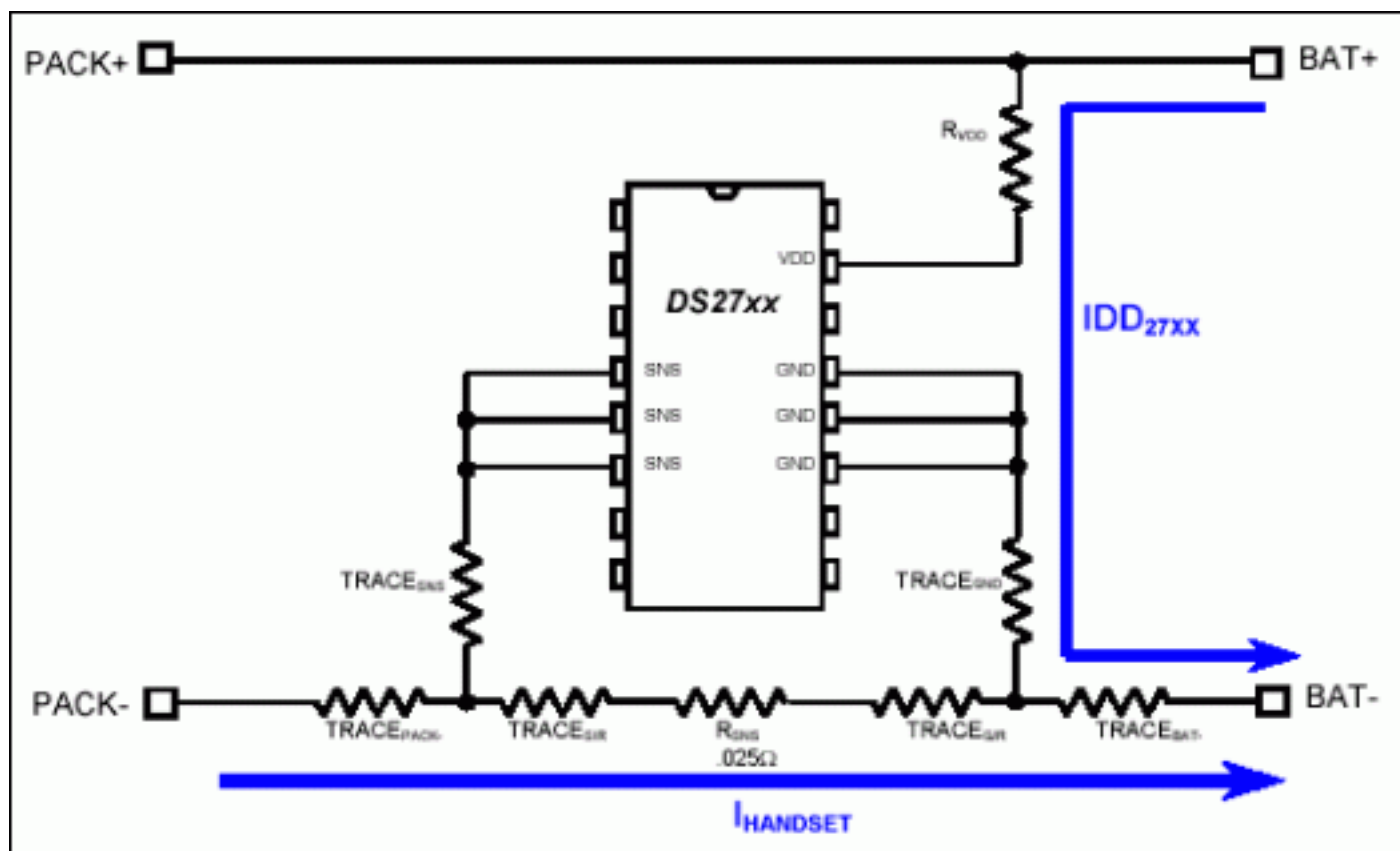

Figure 1. DS27xx measurement system sources of error.

**Figure 1** shows possible sources of measurement error with external sense resistor fuel gauges. Other connections have been left out for simplicity. The fuel gauge accumulates current by measuring the voltage drop between the points where the sense lines, SNS and GND, contact the application current path,  $I_{\text{HANDSET}}$ . Ideally these contact points would be directly at the sense resistor. Any trace resistance between the contact points and the sense resistor, labeled  $\text{TRACE}_{S/R}$  and  $\text{TRACE}_{G/R}$  in the circuit, will affect the gain error of the measurements as follows:

$$\text{GainError} = \frac{(\text{TRACE}_{S/R} + \text{TRACE}_{G/R} + R_{SNS})}{R_{SNS}}$$

Although trace resistance is normally relatively small even compared to the sense resistor, a typical via could have several milliohms of resistance that would create significant error. Any trace resistance outside the measurement points, labeled  $\text{TRACE}_{\text{PACK-}}$  and  $\text{TRACE}_{\text{BAT-}}$  in the circuit, have no effect on current measurement accuracy.

The second possible source of measurement error is caused by a voltage difference from the ground sense point described earlier and the actual GND pins of the device. This voltage drop is created by the operating current of the device,  $\text{IDD}_{27XX}$ , flowing through any trace resistance between the GND pins and the ground sense point, labeled  $\text{TRACE}_{\text{GND}}$  in the circuit. Since this current flow is always in the same direction it will create an offset error in the fuel gauge measurements as follows:

$$\text{OffsetError} = \frac{(\text{TRACE}_{\text{GND}} \cdot \text{IDD}_{27XX})}{R_{SNS}}$$

Measurement offset is the most significant type of error when determining fuel gauge accuracy, so limiting the amount of ground resistance in the circuit is crucial. Resistance of the sense trace,  $\text{TRACE}_{\text{SNS}}$ , is unimportant since there is no current flow through this sense path.

## Circuit Layout

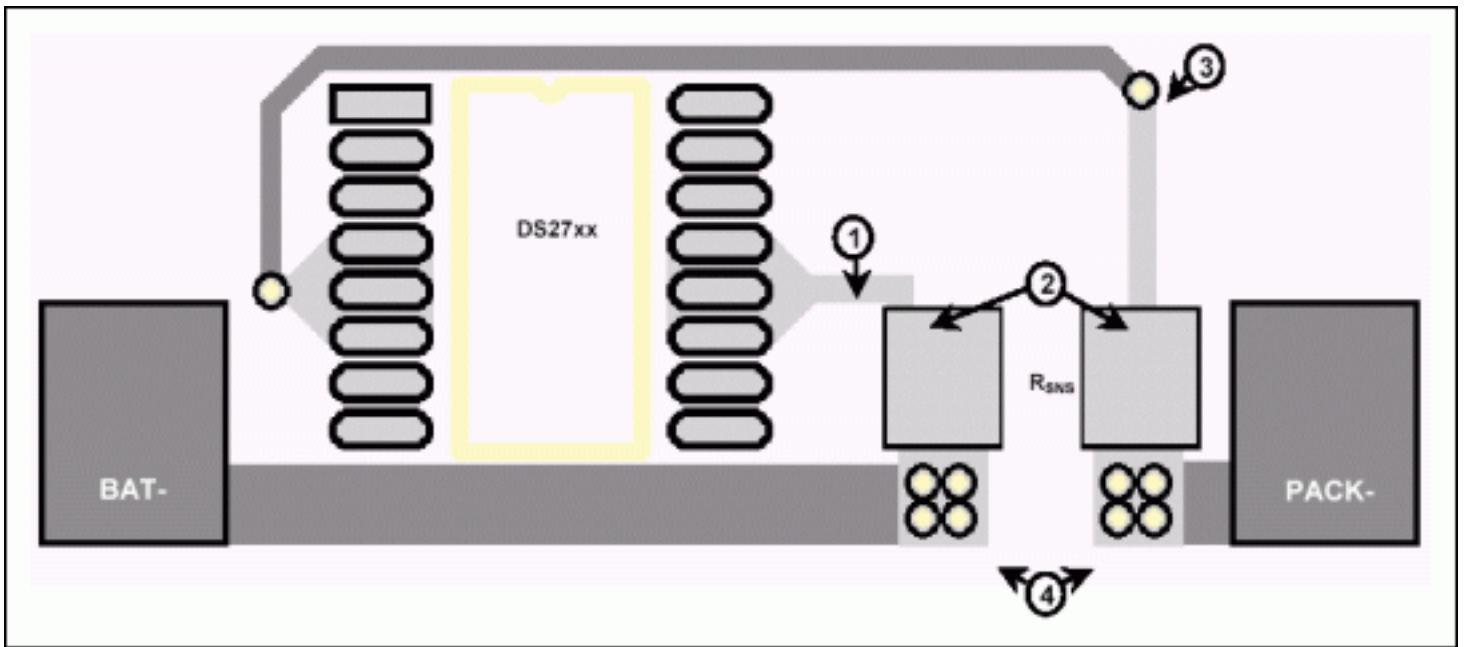

Figure 2. DS27xx circuit layout considerations.

**Figure 2** shows a sample layout of a DS27xx fuel gauge incorporating the design methods described above. Key points of the layout labeled in Figure 2 are described as follows.

- (1) The resistance in the trace from GND pins to the BAT- side of the sense resistor has been minimized by keeping the trace short and eliminating all vias.
- (2) Both sense lines contact the main current path directly at the sense resistor. There is very little board trace shared with the main current path and no shared vias.
- (3) Resistance of the SNS pin connection is unimportant. The trace can be long and can contain vias without affecting measurement accuracy.
- (4) Vias and any other resistances in the main current path are external to where the sense points contact the sense resistor and therefore do not affect measurement accuracy.

## Summary

Board layout is extremely important to maintaining the datasheet accuracy of external sense resistor fuel gauges. Care must be taken to minimize trace resistances that can generate offset or gain errors in the device measurements. These layout methods apply only to external resistor devices. This circuit is self-contained in internal resistor devices and is thus not affected by the sources of error described here.

Application Note 2416: <http://www.maxim-ic.com/an2416>

### More Information

For technical questions and support: <http://www.maxim-ic.com/support>

For samples: <http://www.maxim-ic.com/samples>

Other questions and comments: <http://www.maxim-ic.com/contact>

### Related Parts

DS2760: [QuickView](#) -- [Full \(PDF\) Data Sheet](#) -- [Free Samples](#)

DS2761: [QuickView](#) -- [Full \(PDF\) Data Sheet](#) -- [Free Samples](#)

DS2762: [QuickView](#) -- [Full \(PDF\) Data Sheet](#) -- [Free Samples](#)

DS2770: [QuickView](#) -- [Full \(PDF\) Data Sheet](#) -- [Free Samples](#)

AN2416, AN 2416, APP2416, Appnote2416, Appnote 2416

Copyright © 2005 by Maxim Integrated Products

Additional legal notices: <http://www.maxim-ic.com/legal>