



**Keywords:** MAX5052, pwm controller, synchronous rectification, forward converter, high efficiency, power supply, power supplies, forward converter, input reverse voltage protection, pulse width modulation, controllers

Sep 01, 2003

#### APPLICATION NOTE 2400

## A Compact 36-72V DC Input, 3.3V/10A Output Power Supply

*Abstract: A compact power supply that provides a regulated 3.3V at currents up to 10A using the MAX5052A PWM controller is described here. This power supply operates from -36V to -72V and uses synchronous rectification to achieve efficiencies greater than 88% at 10A. It uses a single transistor forward converter with a reset winding and has a maximum duty cycle of 50%. It has input reverse voltage protection, and will regulate to zero load. The isolation voltage is 1500V and it has over-voltage and over-current protection. It can be turned on and off by the remote on/off pin and it has a thermal shutdown feature which protects the supply from excessive temperatures. The unit has hiccup current limit to limit the RMS current during an output short.*

### General Description

The output of this power supply is an isolated 3.3V/10A output, produced from an input is 36-72V DC. Airflow is required at higher ambient temperatures to get the full rated power.

The topology used is a single transistor forward, with a reset winding on the transformer to reset the core. The maximum duty cycle is less than 50%. The design uses the MAX5052A PWM controller.

### Specifications for power supply

Input -36V to -72V DC  
Output 3.3V  
Full load current 10A  
Minimum load 0A  
Load and Line Regulation  $\pm 1\%$   
Isolation voltage 1500 VDC  
Over-voltage protection  
Over-current protection  
Remote on/off (active high)  
Thermal shutdown  
Input reverse voltage protection  
Efficiency >85% at full load

Some of the features of the power supply are discussed below

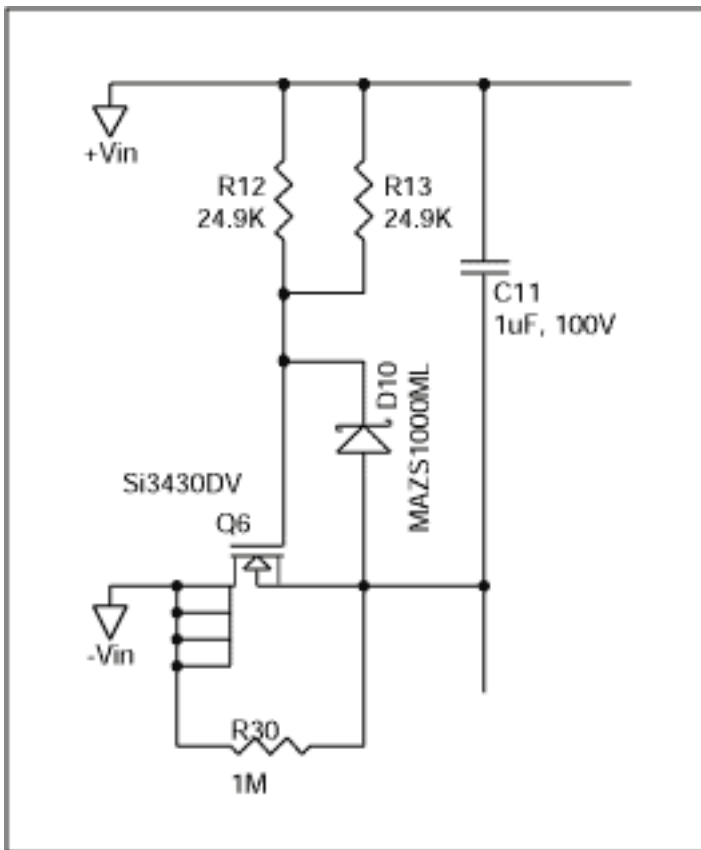

Figure 1. Reverse voltage protection.

The input of the power supply is protected from the application of reverse voltages by the circuit formed by Q6, R12, R13, R30 and D10. When the input voltage is of the correct polarity, then the body diode of Q6 is forward-biased. The zener voltage appearing across D10 fully turns on Q6 and the current now flows through the MOSFET Q6, thus limiting the dissipation. When the voltage is reversed, the MOSFET Q6 is turned off and most of the reverse voltage now appears across the MOSFET Q6 and very little current is drawn from the input.

## Primary control, bias, drive and short circuit protection

The MAX5052A PWM controller has all the necessary control circuitry required for the design of an isolated power supply. The under-voltage lockout disables the drive until the voltage on the UVLO pin 1 goes higher than 1.23V. UVLO pin is enabled at 34V and is disabled on its way down at 32.6V. This guarantees that the power supply is on at 36V dc.

The feedback voltage from the opto-coupler appears on the junction of R14 and R15. Resistor R17, R16 and C14 form the compensation components on the primary. The current sense voltage appears on resistor R21. Resistor R20 and C15 filter out the current spike voltage at turn-on and the resultant voltage is fed to the CS pin on the MAX5052A controller. Since the duty cycle is less than 50% slope compensation is not required. Start-up of the converter is achieved through resistor R4 and C1.

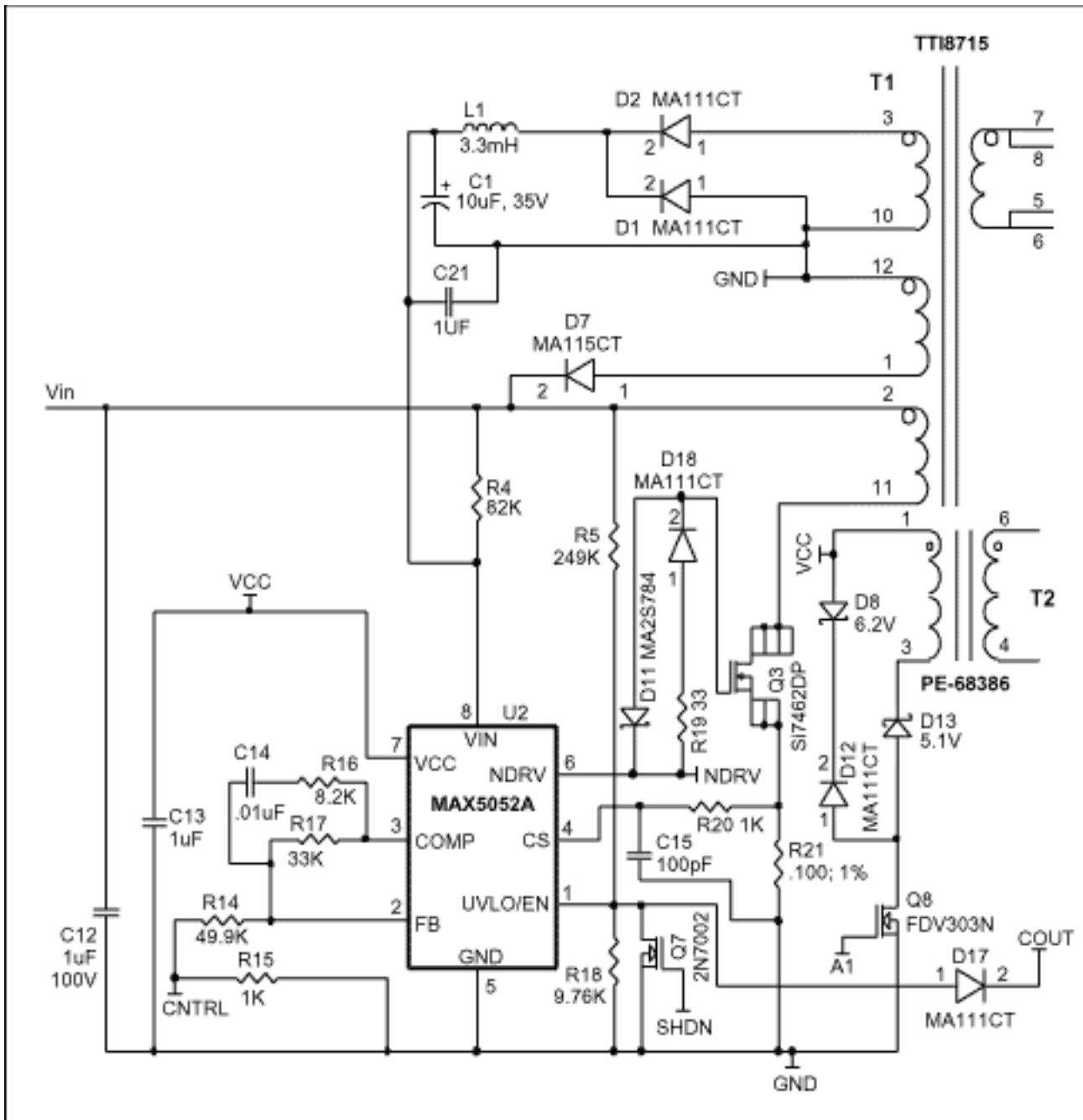

Figure 2.

Capacitor  $C1$  charges up to 21.6V through  $R4$  and when the UVLO pin is enabled, the PWM controller gate drive comes on. The digital soft start increases the pulse width slowly to the desired pulse width. The transformer winding voltage across pins 3 and 10 is rectified and the average rectified voltage will appear across  $C1$ . Inductor  $L1$  is used for averaging purposes and must be sized such that the inductor is continuous at high line. This averaging circuit causes the power supply to go into hiccup mode during short circuit. Since the average output voltage on  $C1$  is equal to the output voltage times the turns ratio of the primary bias winding to the secondary power winding, the voltage on  $C1$  is proportional to the output voltage. Now when the output goes into current limit, the output voltage drops causing the primary bias voltage to drop. As the output goes deeper and deeper into current limit, the bias voltage will drop further until it drops below 9.74 volts, the bootstrap UVLO lower threshold. This will cause the power supply to shut down. The power supply will remain off until the bootstrap capacitor  $C1$  charges up to 21.6V and the cycle will begin all over. This will limit the overall RMS short circuit current on the output. The drive voltage appears on the NDRV pin and this turns on and off the MOSFET  $Q3$ . The reset winding is formed by the primary windings from pins 12 to 1 and it has the same no of turns as the primary power winding from pins 2 to 11 on the transformer.



Q5 is a little bit more difficult to obtain as compared to that of Q1. The gate of Q5 should be turned on after you turn off Q3 or Q1. It is also important that Q5 be turned off before turning on Q3 to avoid a short across the transformer secondary winding.

It is also important that Q5 be kept on during the portion of the interval where the secondary winding voltage is zero to maximize efficiency. This requires that the control signal of Q5 be obtained from the primary and sent across a separate isolation transformer T2.

T2 is a separate gate drive transformer that is used to obtain the drive signal for Q5. The voltage across the transformer secondary winding goes positive when the FET Q8 is turned on. Q8 is driven by the NDRV pin on U2. Since Q8 is a very small FET with a very low gate charge, the voltage across T2 secondary will go positive before the MOSFET Q3 is turned on which has a much higher gate charge than Q8 and a higher gate threshold voltage. This will cause a positive voltage to appear across the IN- pin of the MAX5048B SOT23 driver resulting in turning off MOSFET Q5.

We have thus achieved the turn-off of Q5 just before the turn-on of Q3. When Q3 is turned off by the NDRV pin In- pin on U1 goes low and turns on Q5. We have thus obtained the proper gate drive voltage waveform for Q5. A regulated bias voltage for U1 is obtained by the regulator formed by Q2,D6,R3 and C5. The voltage on C3 will vary from 9 to 18V while the voltage on C5 is regulated approximately at 9.5 volts. This voltage provides the appropriate gate drive voltage for Q5 and also lowers the dissipation in the gate charge turn-on and turn-off circuit for Q5. A 3A 30V schottky diode D4 is connected directly across the drain to source of Q5 so as to lower the reverse recovery in the body diode of Q5 by carrying the majority of the current when the MOSFET Q5 is turned off.

Inductor L2 and capacitors C7, C10 and C4 form the output low pass filter. The ESR of C7 is less than 5mΩ. The high frequency capacitor C9 returns all the high frequency currents caused by the primary to secondary winding capacitances back to the primary and lowers the noise appearing on the output due to these currents.

## **Secondary margining, regulation, OVP and primary remote on/off circuitry**



The primary bias for the dual comparator and reference in U5 is obtained across C23. The resistors R34, R35 and the zener diode D16 provide a voltage of 3.8V for the Vcc pin in U5. This voltage is always present if the input voltage is applied to the input of the supply. Since the dual comparator draws very little current we can use two 42K resistors in parallel to provide the voltage for U5.

The remote on/off pin is connected to C18 and when it is left open, the remote on/off is in the on stage. The output of comparator A is high and the power supply is turned on as long the input voltage is above the under-voltage point and the power supply is not in OVP. When the remote on/off pin is brought below 2.5 volts, the output of the comparator A goes low. This will pull down on UVLO pin of U2 and cause it to turn off the supply. At the same time the OVP latch would be reset because the emitter of the OVP optical coupler U6 would be pulled low.

Thermal shutdown occurs if pin 5 on U8 goes low. U8 is a thermal sensor (MAX6501UKP105) with an open drain output pin on pin 5 that goes low when the temperature exceeds 105 degree C. Once the power supply shuts down due to thermal shutdown or OVP it has to be recycled by cycling input power or by cycling the remote on/off pin.

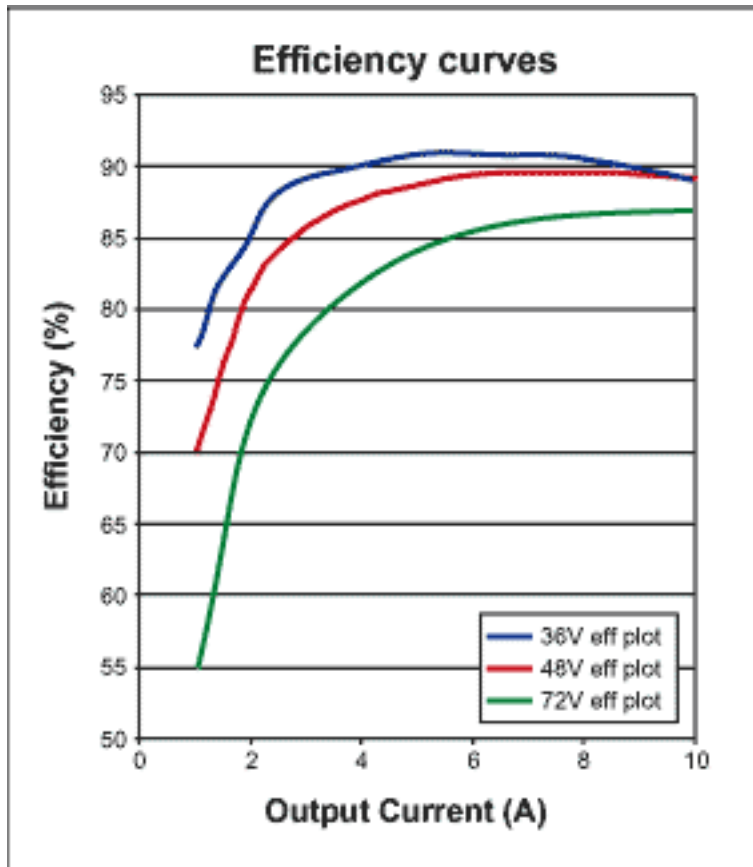
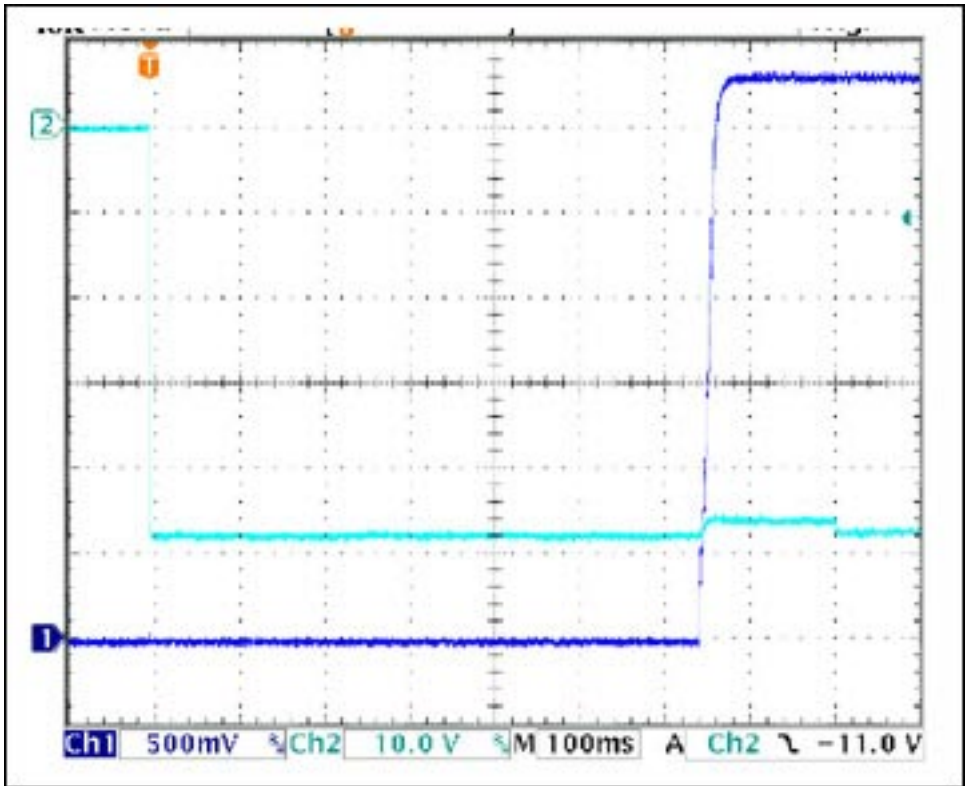

Figure 5. Test data for the 33watt power supply.

## Turn on at -48V and full load

Channel 2 is the input voltage at 10V per division  
Channel 1 is the output voltage at 0.5V per division



### Turn on at -48V and no load

Channel 1 is the output voltage at 0.5V per division

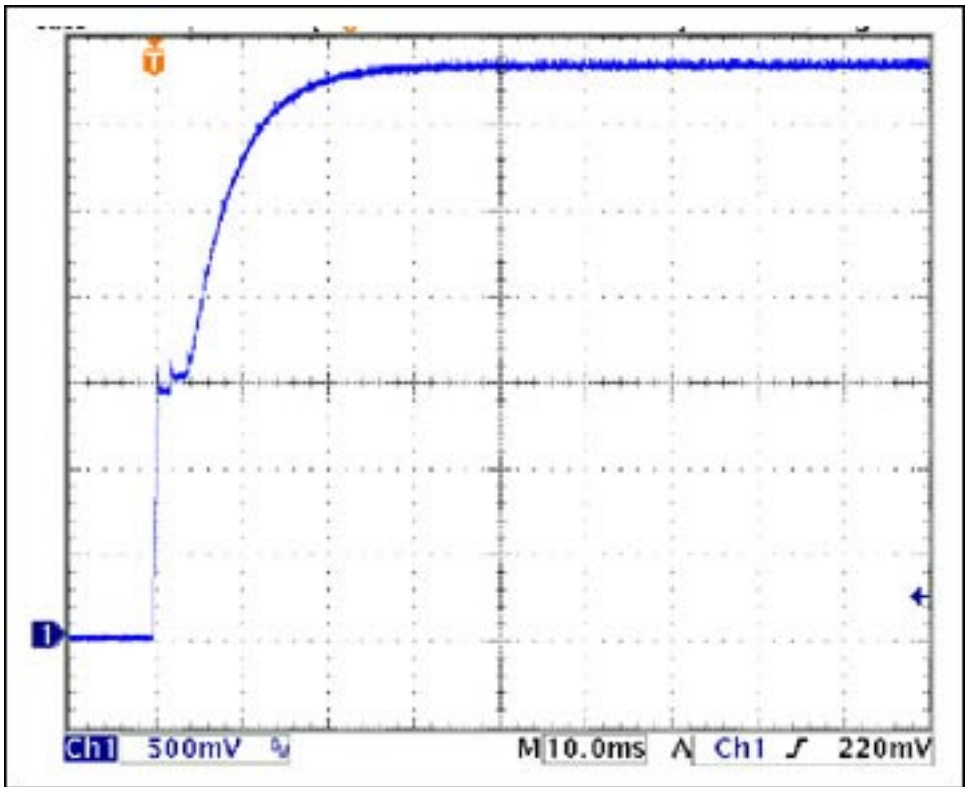

Notice that there is no overshoot on turn-on at no load. This is due to the digital soft start function in the MAX5052A

## Turn on at 72V with the input voltage reversed

Channel 1 is the input voltage at 20V per division  
Channel 2 is the input current at 0.1A per division

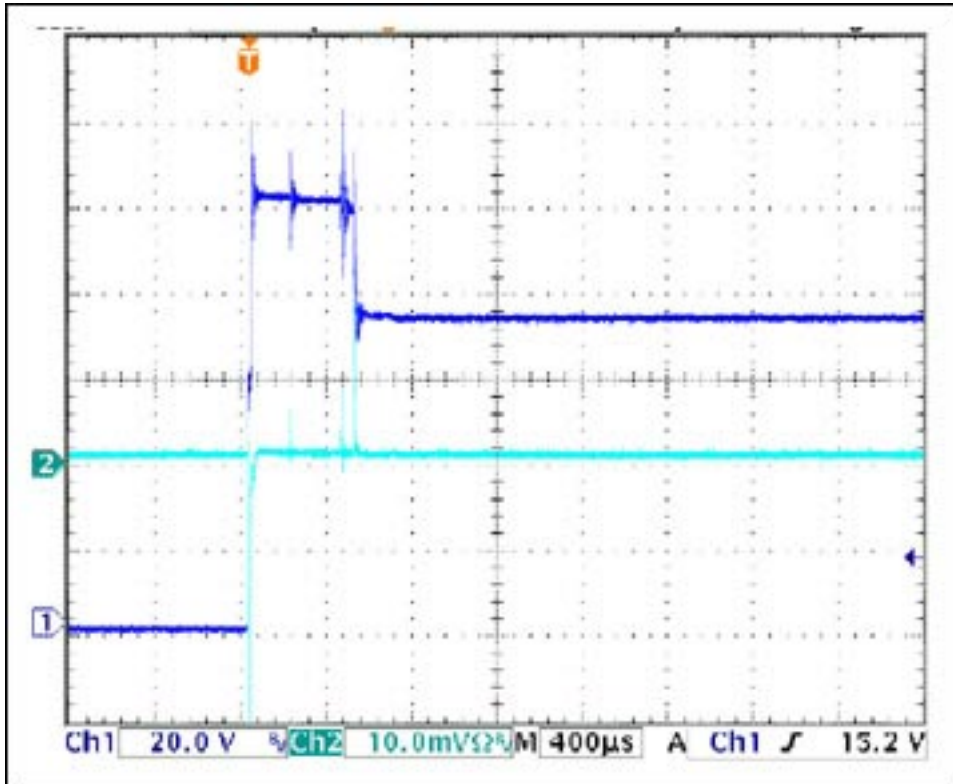

The unit worked fine after the voltage was re-applied in the proper direction

## Transient response from 7.5A to 5A to 7.5A (75% to 50% to 75% of rated load)

Channel 1 is the output voltage at 0.1V per division  
Channel 2 is the output current at 2A per division  
Test performed at 48V input

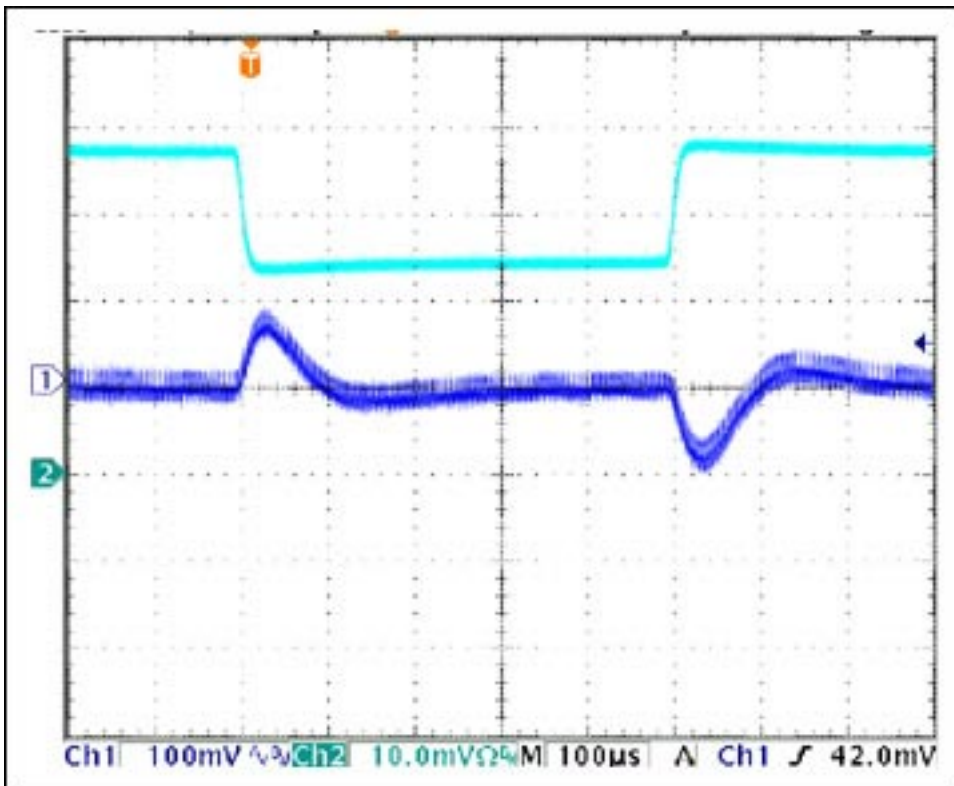

The overshoot for a 25% load increase is 80mv and the under-shoot for a 25% load decrease is 80mv. The recovery time is 100 microseconds.

### Short circuit current at 72V input

Channel 1 is output short circuit current at 10A per division

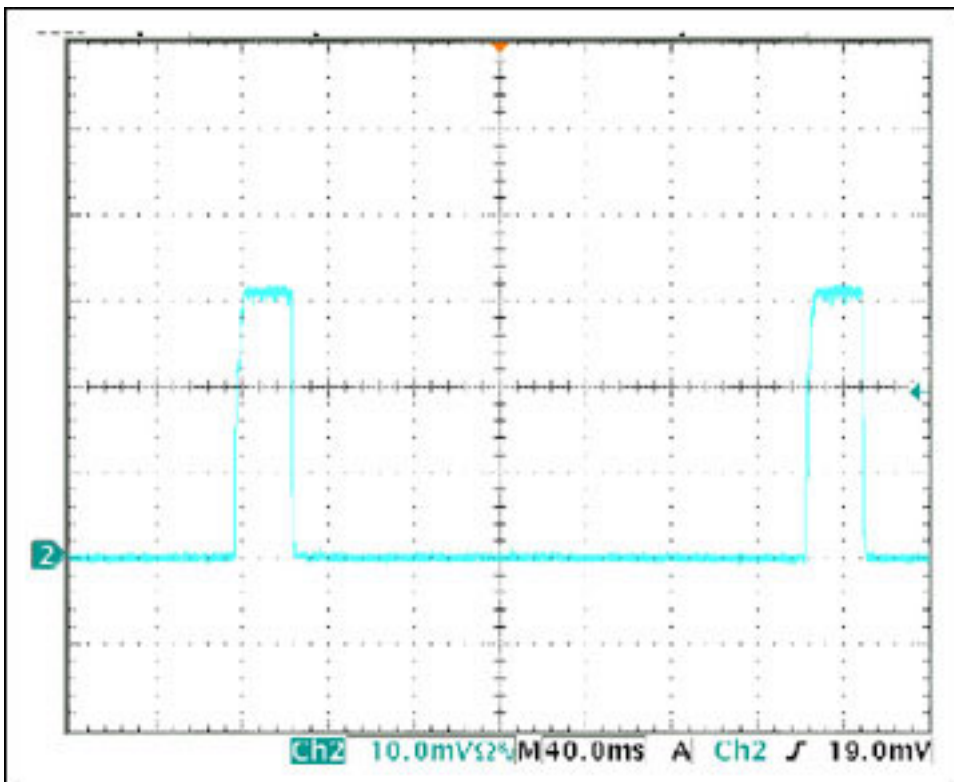

The peak short circuit current at 72V is 30A. The RMS current is 10.8A The unit recovers to full rated load when the short is removed.

## Peak to peak ripple noise at 20 Mhz bandwidth (36V input)

Channel 1 is 20 mv per division

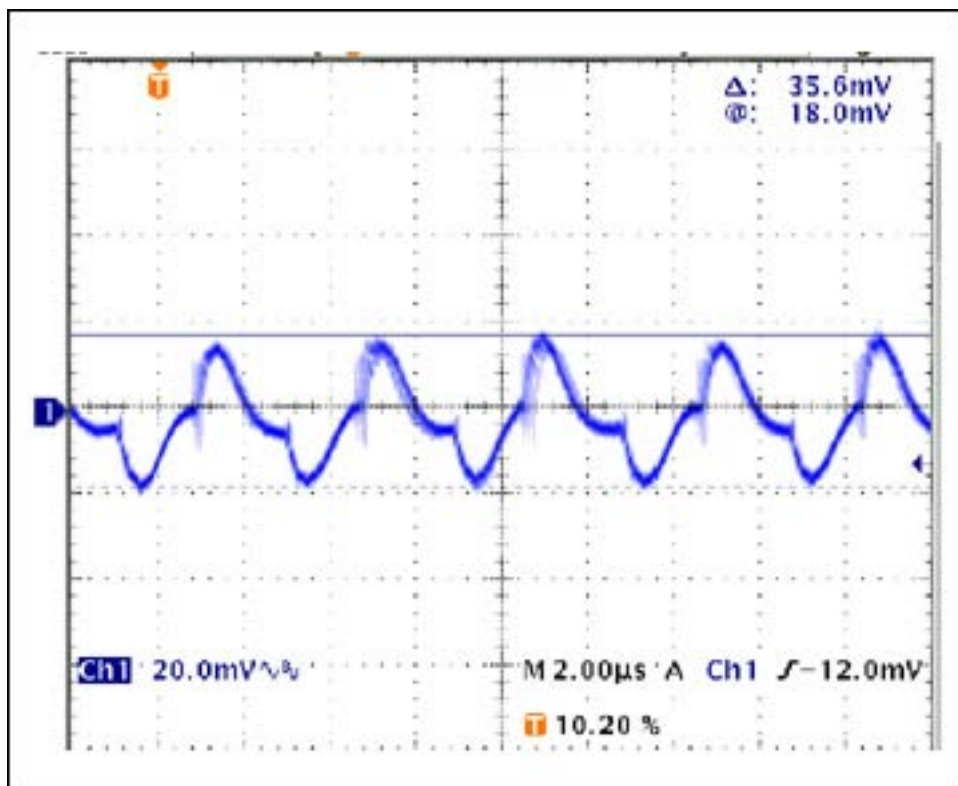

The peak -to- peak ripple at 36V input and full load is 35.6 mv.

## Peak-to-peak ripple at 48V input (20 Mhz bandwidth)

Channel 1 is 20 mv per division

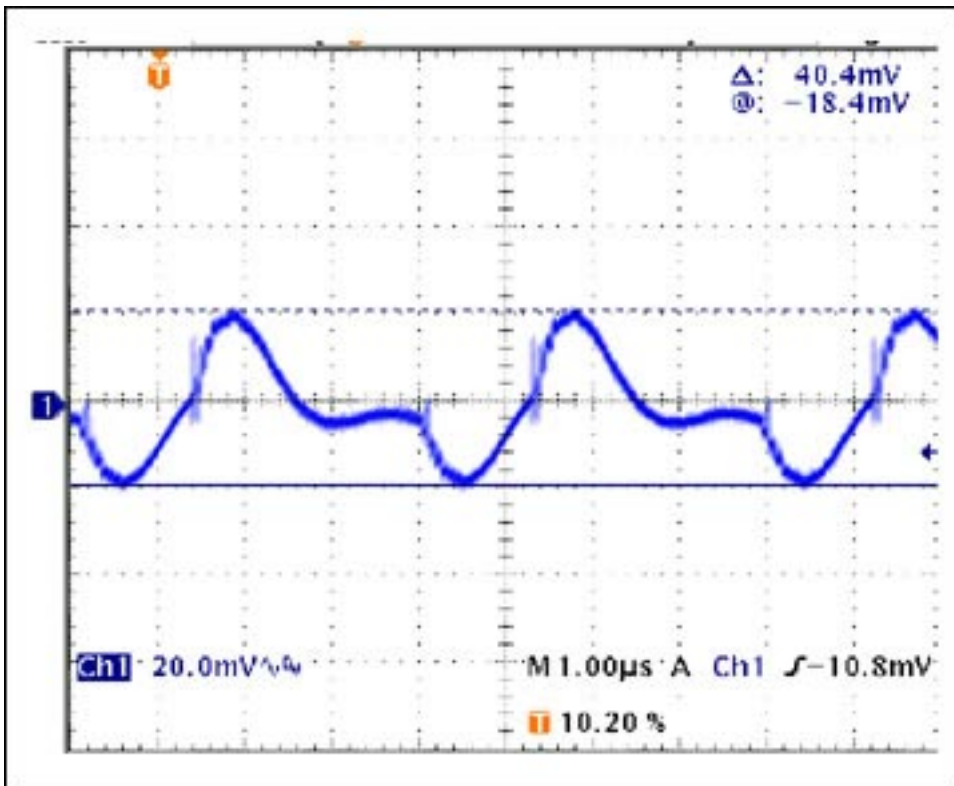

The peak to peak ripple at 48V input and full rated load is 40.4mv.

### Peak-to-peak ripple at 72V input (20 Mhz bandwidth)

Channel 1 is 20 mv per division

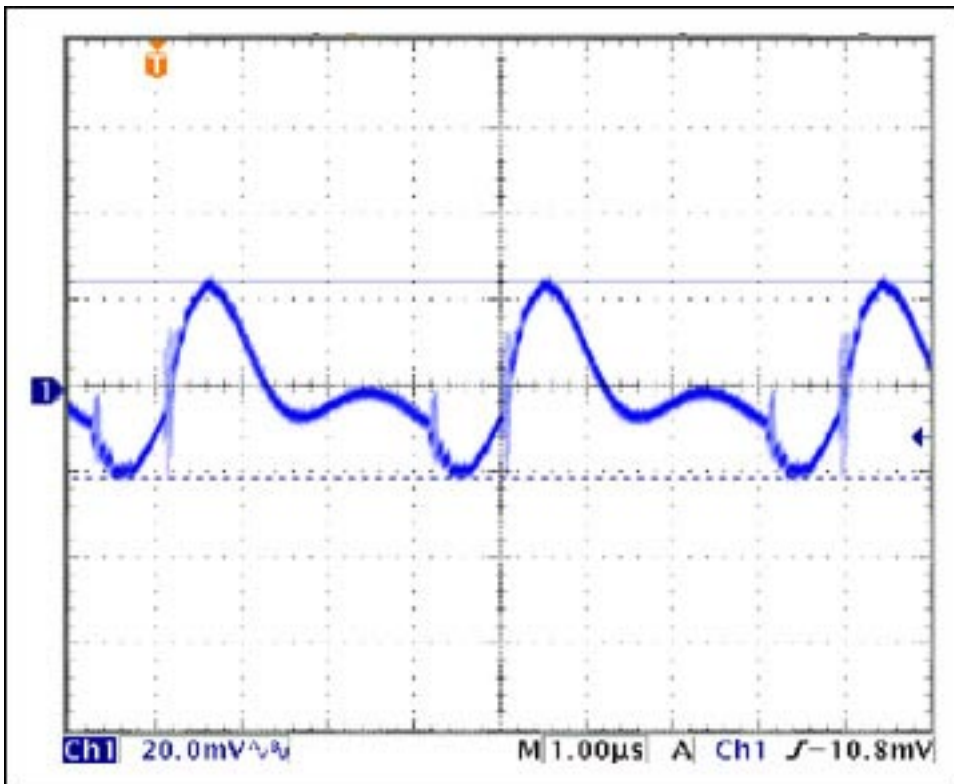

The peak to peak ripple at 72V input and full rated load is 46mv.

Note: The peak to peak ripple was measured with the standard measurement technique used for dc-dc modules.

This involved the adding of a 1uF ceramic capacitor in parallel with a 10uF, 100 mΩ esr tantalum capacitor at the output and the noise was measured directly across the 1uF ceramic capacitor.

The ripple and noise will certainly improve in the production unit because the production unit would use 2oz copper. In the evaluation PCB we used 1oz copper on the board and this caused additional ESR on the output connections to the output capacitors. With the ESR reduced the ripple and noise would improve. Also in a new layout we would place the output capacitors (C7 and C20) directly across the output terminals.

Control loop measurements: Since the unit employs current mode control and uses synchronous rectifiers the output choke is always continuous. The measurement of the control loop revealed the crossover frequency to be 8.912 Khz and the phase margin to be 59 degrees.

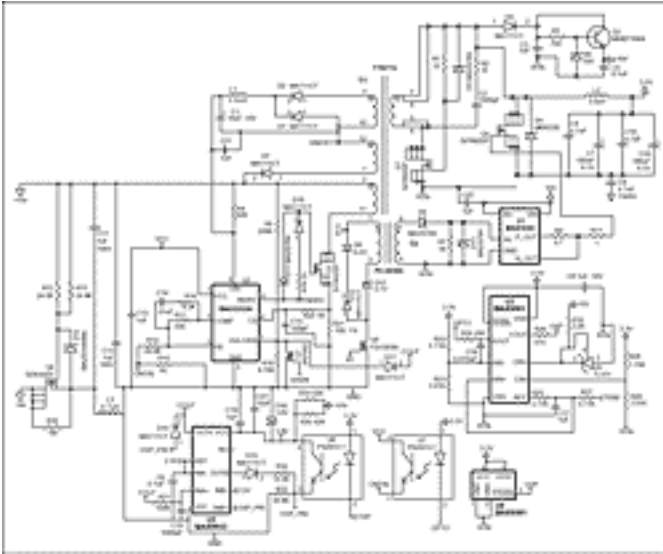

[Larger Image](#)

Figure 14. Power supply schematic.

**Table 1. Component list for power supply.**

Designator	Description	Footprint	Vendor	Vendor part no
C1	Electrolytic capacitor 10uF, 35V	EEVFK1V100UR	PANASONIC	EEVFK1V100UR
C10, C4	Ceramic capacitor 4.7uF, 6.3V, X5R	805	TDK	C2012X5R0J475M
C11, C12	Ceramic capacitor 1uF, 100V, X7R	1812	TDK	C4532X7R2A105M
C13	Ceramic capacitor 1uF, 16V, X7R	805	TDK	C2012X7R1C105M
C14	Ceramic capacitor 0.01uF, 25V, X7R	402	TDK	C1005X7R1E103K
C15	Ceramic capacitor 100pF, 50V, X7R	402		
C16	Ceramic capacitor 0.01uF, 25V, X7R	402	TDK	C1005X7R1E153K
C17	Ceramic capacitor 1uF, 10V, X5R	603	TDK	C1608X5R1A105M
C18	Ceramic capacitor 1000pf, 50V, X7R	402		
C19, C22, C8	Ceramic capacitor 1uF, 10V, X5R	603	TDK	C1608X5R1A105M
C2	Ceramic capacitor 1000pf, 100V, X7R	603		
C21	Ceramic capacitor 0.1uF, 50V, X7R	805		
C23	Ceramic capacitor 10uF, 6.3V, X5R	805	TDK	C2012X5R0J106M

C3, C5	Ceramic capacitor 0.1uF, 25V, X7R	603		
C6	Ceramic capacitor 0.1uf, 10V, X5R	402	TDK	C1005X5R1A104K
C7, C20	Specialty polymer capacitor 180uF, 6.3V	EEFUE0J181XR	PANASONIC	EEFUE0J181XR
C9	Ceramic capacitor 4.7nF, 250VAC	1812	Murata	GA243DR7E2472MW01L
D1, D11, D18, D13	Switching diode 80V, 100ma	SSMINI2P	PANASONIC	MA111CT
D12, D14, D15, D17				
D2, D5				
D10, D6	Zener diode 10V, 150mw	SSMINI2P	PANASONIC	MAZS1000ML
D13	Zener diode 5.1V, 200mW	SOD323	Diodes Inc	BZT52C5V1S
D16	Zener diode 3.7V, 200mw	SOD323	Diodes Inc	BZT52C3V9S
D3, D9	Schottky diode 30V, 100ma	SSMINI2	PANASONIC	MA2S78400L
D4	Schottky diode 30V, 3A	SMA	Diodes Inc	B330A
D7	Silicon epitaxial planar diode 200V, 200ma	Smini2	PANASONIC	MA115CT
D8	Zener diode 6.2V, 200mw	SOD323	Diodes Inc	BZT52C6V2S
L1	Inductor 3.3mH, 24ma	DS1608	Coilcraft	DS1608-335
L2	Inductor 3.0uH, 12.4A		SUMIDA	CDEP1493R0
L3	Inductor 4.7uH	DO1608C	Coilcraft	DO1608-472
Q1, Q5	N channel MOSFET 30V, 25A	Power-PAK SO8	Siliconix	Si7892DP
Q2	General purpose NPN transistor 200ma	SOT23-2		MMBT3904
Q3	N channel MOSFET 200V, 4.1A	Power-PAK SO8	Siliconix	Si7462DP
Q6	N channel MOSFET 100V, 0.17 Ω	SSOT6	Siliconix	Si3430DV
Q7	N channel MOSFET 60V, 240 ma	SOT23-2		2N7002
Q8	N channel MOSFET 25V, 0.68A	SOT23-2	Fairchild Semi	FDV303N
R1	22	402		
R10	2.2K	402		
R11	1	402		
R12, R13	24.9K	1206		
R14, R33	49.9K	402		
R15, R7	1K	402		
R16	8.2K	402		
R17	33K	402		
R18	9.76K	402		
R19	33	402		
R2	10	1206		
R20	1K	402		
R21	.100; 1%	1206		
R22, R25, R27	5.11K	402		
R23, R29	3.01K	402		
R24	200	402		
R26	470	402		

R28	1.75K	402		
R3	750	402		
R30	1M	603		
R31	100K	402		
R32	14.3K	402		
R34, R35	42K	1206		
R4	82K	805		
R5	249K	603		
R9	4.7	402		
T1	Custom transformer	TTI8715	Transpower	TTI8715
T2	Gate drive transformer 1:1	PE-68386	Pulse Engg	PE68386
U1	7.6A, 12ns, SOT23 MOSFET Driver	SOT23-6	MAXIM	MAX5048BAUT-T
U2	Current-Mode PWM Controller	8 uMAX	MAXIM	MAX5042AEUA
U3	Low-Power, High-Speed, Single-Supply Op Amp Comparator Reference ICs	10 uMAX	MAXIM	MAX9001EUB
U4	Adjustable shunt regulator	SOT23-5		TL431IDBVR
U5	Micropower, Single-Supply, UCSP/SOT23 Comparator + Precision Reference ICs	10 uMAX		MAX9053AEUA
U6, U7	4 pin photocoupler		CEL	PS2913-1-M
U8	Low-Cost, +2.7V to +5.5V, Micropower Temperature Switches in SOT23 and TO-220	SOT23-5	MAXIM	MAX6501UKP105

Application Note 2400: <http://www.maxim-ic.com/an2400>

### More Information

For technical questions and support: <http://www.maxim-ic.com/support>

For samples: <http://www.maxim-ic.com/samples>

Other questions and comments: <http://www.maxim-ic.com/contact>

### Related Parts

MAX5048: [QuickView](#) -- [Full \(PDF\) Data Sheet](#) -- [Free Samples](#)

MAX5048: [QuickView](#) -- [Full \(PDF\) Data Sheet](#) -- [Free Samples](#)

MAX5052: [QuickView](#) -- [Full \(PDF\) Data Sheet](#)

MAX5052A: [QuickView](#) -- [Full \(PDF\) Data Sheet](#) -- [Free Samples](#)

MAX6501: [QuickView](#) -- [Full \(PDF\) Data Sheet](#) -- [Free Samples](#)

MAX9001: [QuickView](#) -- [Full \(PDF\) Data Sheet](#) -- [Free Samples](#)

MAX9053: [QuickView](#) -- [Full \(PDF\) Data Sheet](#)

AN2400, AN 2400, APP2400, Appnote2400, Appnote 2400

Copyright © by Maxim Integrated Products

Additional legal notices: <http://www.maxim-ic.com/legal>