

APPLICATION NOTE 239

Regulated LCD-Bias Generator Requires No Inductor

Abstract: This design idea shows how a regulated LCD bias generator requires no inductor. A charge-pump design based on the MAX868 regulated, inverting charge pump replaces a switch-mode design to generate a negative voltage for biasing an LCD. A few components in the feedback path of a negative, inverting charge pump produce an inverter-quadrupler circuit.

A similar idea appeared in the March 9, 1998 issue of *Electronic Design*.

A stringent height limitation on the PC boards for personal digital assistants (PDAs) and palmtop computers compels the use of expensive, low-profile inductors in switch-mode power supplies. As an alternative, however, certain switch-mode circuits can be replaced with one based on a charge pump (Figure 1). This example generates a regulated negative voltage suitable for biasing an LCD.

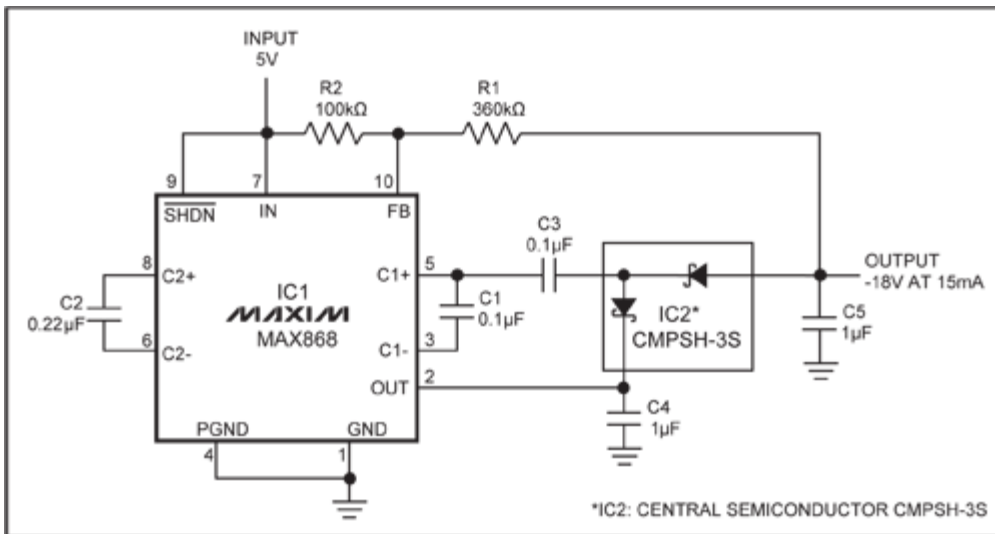

Figure 1. Adding a few inexpensive components in the feedback path of IC1 enables the generation of regulated output voltages nearly as high as $-4V_{IN}$.

IC1 contains a regulated, inverting charge pump that produces output voltages as high as $-2V_{IN}$, in which the supply voltage (V_{IN}) can range from +1.8V to +5.5V. The IC regulates V_{OUT} through pulse-frequency modulation (PFM), with a maximum frequency of 450kHz. The IC's low quiescent current (30μA) provides excellent light-load efficiency without sacrificing full-load capability.

Inserting an external, discrete charge pump (consisting of C3, C4, and the Schottky diodes) in the feedback path of IC1 produces an "inverter-quadrupler" circuit whose regulated output level is set by the ratio of feedback resistors R1 and R2:

$$V_{OUT} = -V_{IN} (R1/R2)$$

Configured as shown, the circuit provides up to 15mA at $V_{OUT} = -18V$, with 76% efficiency and 60mV of output voltage ripple. Lower V_{OUT} allows higher output currents: $V_{OUT} = -15V$ yields 20mA, and $V_{OUT} = -12V$ yields 30mA.

Related Parts

[MAX868 Regulated, Adjustable -2x Inverting Charge Pump -- Free Samples](#)

Automatic Updates

Would you like to be automatically notified when new application notes are published in your areas of interest? [Sign up for EE-Mail™](#).

Application note 239: www.maxim-ic.com/an239

More information

For technical support: www.maxim-ic.com/support

For samples: www.maxim-ic.com/samples

Other questions and comments: www.maxim-ic.com/contact

AN239, AN 239, APP239, Appnote239, Appnote 239

Copyright © by Maxim Integrated Products

Additional legal notices: www.maxim-ic.com/legal