



APPLICATION NOTE 2372

A Comparison between Battery Backed NV SRAMs and NOVRAMS

Abstract: Dallas Semiconductor nonvolatile (NV) SRAMs are backed up with an internal battery. Some other NV memories on the market, such as NOVRAMs, back up the data with internal EEPROM. This application note discusses the differences between battery backed NV SRAMs and NOVRAMs.

NVSRAMs

Dallas Semiconductor NVSRAMs (**Figure 1**) have an internal lithium power source and self-contained control circuitry that constantly monitors V_{CC} for an out-of-tolerance condition. When such a condition occurs, the lithium battery automatically switches on and write protection is unconditionally enabled to prevent data corruption. There is no limit on the number of write cycles that can be executed and no additional support circuitry is required for microprocessor interfacing. Dallas NVSRAMs also reliably store data for up to 10 years, solely on battery power. Data is stored at least 100 years when V_{CC} is powered. DIP-package devices can be used in place of existing static RAMs directly conforming to the popular byte-wide 28- or 32-pin DIP standard. Surface-mount parts are also available.

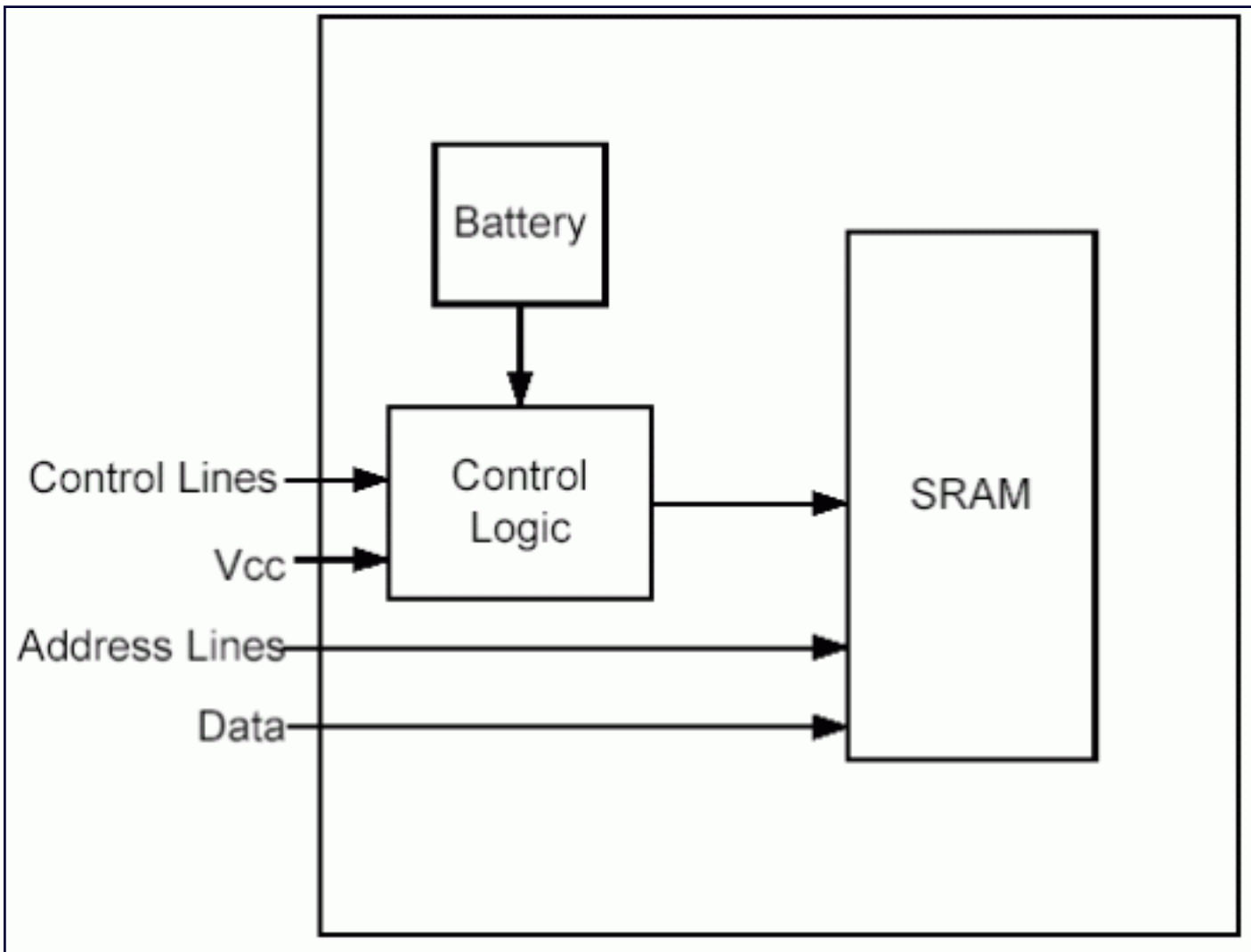

Figure 1. Battery-backed NVSRAM.

NOVRAMs

NOVRAMs (**Figure 2**) do not have an internal battery; instead they have internal EEPROM in which the data is stored. Data is transferred to and from the EEPROM with custom firmware that contains store and retrieve commands. These commands can be automatic or initiated through hardware or software.

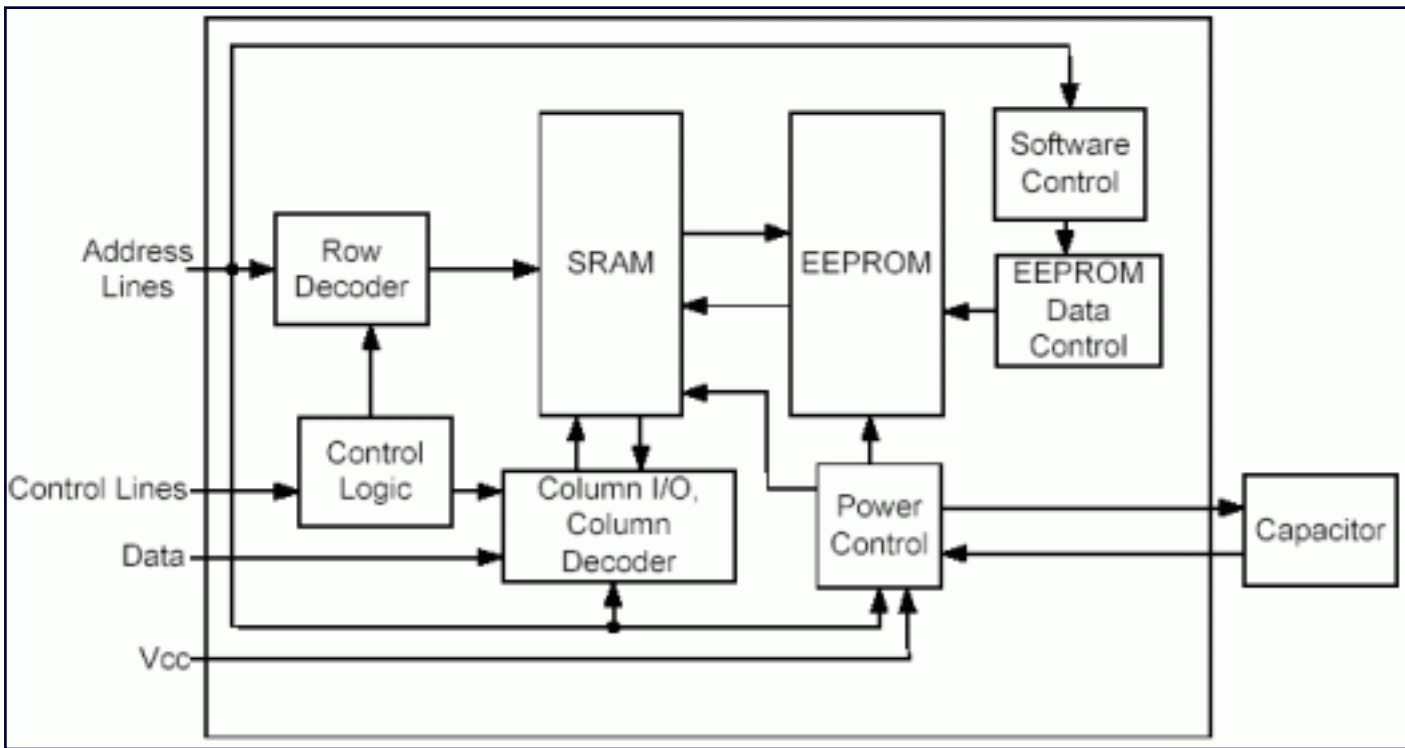

Figure 2. NOVRAMs.

Differences Between NVSRAMs and NOVRAMs

There are many differences between NVSRAMs and NOVRAMs. For simplicity, the differences have been grouped into the following categories: Write Cycles, Time to Store and Retrieve Data, Ease of Use, and Standard Pin-out.

Write Cycles

Battery-backed NVSRAMs can be written an unlimited number of times. When using NOVRAMs, the write cycles are limited. EEPROM can usually be written only 1,000,000 times before it wears out.

Time to Store and Retrieve Data

With a Dallas NVSRAM, the user does not have to be concerned about storing or retrieving data. Data is automatically stored and recalled. The time to store data, on power loss, in a Dallas NVSRAM is 1.5 μ s, compared to 10ms in NOVRAMs. To store or retrieve data in the EEPROM, the user must use a software command or toggle a pin. Multiple address read sequences must be completed to store data. NOVRAMs take 20 μ s and several address read sequences to retrieve the data stored in the EEPROM. NOVRAM cannot be read or written while storing or retrieving data to or from EEPROM.

Ease of Use

Dallas NVSRAMs are more convenient to use since they do not require any additional components. NOVRAMs need an extra capacitor to provide power to the EEPROM. A resistor is also recommended between the chip-enable or write-enable pin and V_{CC} to avoid data corruption.

In addition to extra components, NOVRAMs also require custom firmware to store and recall the data from EEPROM. Dallas NVSRAMs, on the other hand, do not require additional firmware to handle preserving and/or retrieving data.

Standard Pin-Out

All Dallas NVSRAMs are JEDEC compatible. NOVRAMs have extra pins that makes the part incompatible with JEDEC standard SRAM and NVSRAM sockets. The extra pins are for store and recall operations. On some devices a chip-select pin is replaced with a store/recall-enable pin.

Conclusion

The advantages of using NVSRAMs versus NOVRAMs are that NVSRAMs store data quickly, no custom firmware is required, write cycles are unlimited, no additional components are needed, and the pin-outs are JEDEC compatible. For assistance in choosing a Dallas Semiconductor NVSRAM for your application, contact Applications Support at MixedSignal.Apps@dalsemi.com.

Application Note 2372: <http://www.maxim-ic.com/an2372>

More Information

For technical questions and support: <http://www.maxim-ic.com/support>

For samples: <http://www.maxim-ic.com/samples>

Other questions and comments: <http://www.maxim-ic.com/contact>

AN2372, AN 2372, APP2372, Appnote2372, Appnote 2372

Copyright © by Maxim Integrated Products

Additional legal notices: <http://www.maxim-ic.com/legal>