



Keywords: delay lines, silicon timed circuits, delay lines, STCs, DS1040, DS1135L, DS1020, DS1045, DS1033, DS1044, DS1007, DS1000, DS1004, DS1005, DS1100, DS1100L, DS1010, DS1021, DS1013, DS1035, DS1023, DS1135 Dec 10, 2002

APPLICATION NOTE 229

Delay Lines Comparison

Abstract: Maxim manufactures several delay lines. This application note compares each programmable delay line and non-programmable delay line to help customers choose the appropriate device for their application. Since many of the features of these devices cannot easily be categorized into fields in the on-line parametric database, the intent of this application note is to show a side-by-side comparison of members of the delay line family and to eliminate the hassles of sifting through numerous data sheets when trying to select a device.

Programmable Delay Lines Comparison

Maxim's programmable delay lines operate from a 5.0V supply and are available in SO or DIP packages. Programmable delay lines offer the customer the ability to program delays after the device has been installed in the application. Each device is described below and key features are compared in **Table 1**. A functional diagram of a programmable delay line is shown in **Figure 1**.

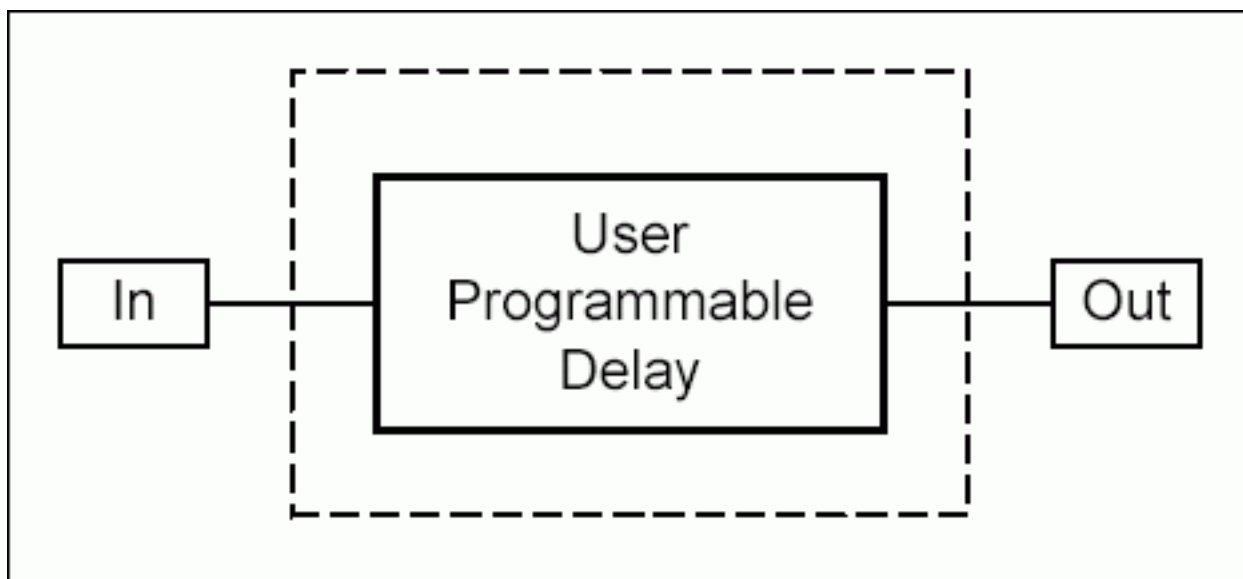

Figure 1. Programmable delay line functional diagram.

DS1020

The DS1020 is an 8-bit delay line. The DS1020 is available in 5 versions (dash numbers) with different step sizes (0.15ns, 0.25ns, 0.5ns, 1ns, and 2ns). Delays are available from 10ns to 520ns and can be programmed using the 3-wire serial interface or the 8-bit parallel interface.

DS1021

The DS1021 is identical to the DS1020 except it is available in only two step sizes (0.25ns and 0.5ns) and it has a minimum V_{CC} power-up time. Delays are available from 10ns to 137.5ns and can be programmed using the 3-

wire serial interface or the 8-bit parallel interface.

DS1023

The DS1023 is similar to the DS1020/1021 with a few added features. This device has the ability to delay signals by up to a full period or more and the signal can also be inverted. The DS1023 can also output a pulse-width modulated signal. The on-chip reference delay creates a step zero delay of 0ns. Delays are available from 0ns to 1275ns with 5 different step sizes (0.25ns, 0.5ns, 1ns, 2ns, and 5ns) and can be programmed using the 3-wire serial interface or the 8-bit parallel interface.

DS1040

The DS1040 is an adjustable one-shot pulse generator. Pulse widths are available from 5ns to 500ns and steps can be programmed from 2.5ns to 100ns, depending on version, using the parallel interface.

DS1045

The DS1045 is a 4-bit dual delay line. This device has two independently programmable outputs. Delays are available from 9ns to 84ns in 3ns, 4ns, or 5ns steps (depending on version) and can be programmed using the parallel interface.

Table 1. Programmable delay lines comparison

	DS1020	DS1021	DS1023	DS1040	DS1045
V _{CC}	5V	5V	5V	5V	5V
Package	16 pin DIP, 16 pin SO	16 pin SO	16 pin DIP, 16 pin SO	8 pin DIP, 8 pin SO	16 pin DIP, 16 pin SO
Step Sizes Available (ns)	0.15, 0.25, 0.5, 1, 2	0.25, 0.5	0.25, 0.5, 1, 2, 5	2.5, 15, 20, 30, 40, 50, 100	3, 4, 5
Number of Program Steps	256	256	256	5	16
Min/Max Delay of Pulse Width (ns)	10/520	10/138	0/1275	5/500	9/84
Enable?	Yes	Yes	Yes	No	Yes
Reference/PWM Output?	No	No	Yes (REF/PWM pin)	No	No
Active Supply Current	30mA	30mA	60mA	75mA	35mA
Number of Outputs	1	1	1	2 (OUT, OUT pins)	2
Programming Interface	3-wire or 8-bit parallel	3-wire or 8-bit parallel	3-wire or 8-bit parallel	3-bit parallel	4-bit parallel

Note: Device specifications have been provided here for device comparison. In the case of discrepancy between this application note and the data sheet, the data sheet supersedes this application note.

Non-Programmable Delay Lines Comparison

Tables 2 and **3** list some of the device specifications for each non-programmable delay line. There are parallel and tapped non-programmable delay lines.

Parallel Delay Lines

The devices listed below are parallel delay lines. Parallel delay lines have multiple, independent delay cells. See **Figure 2** for a functional diagram of a parallel delay line.

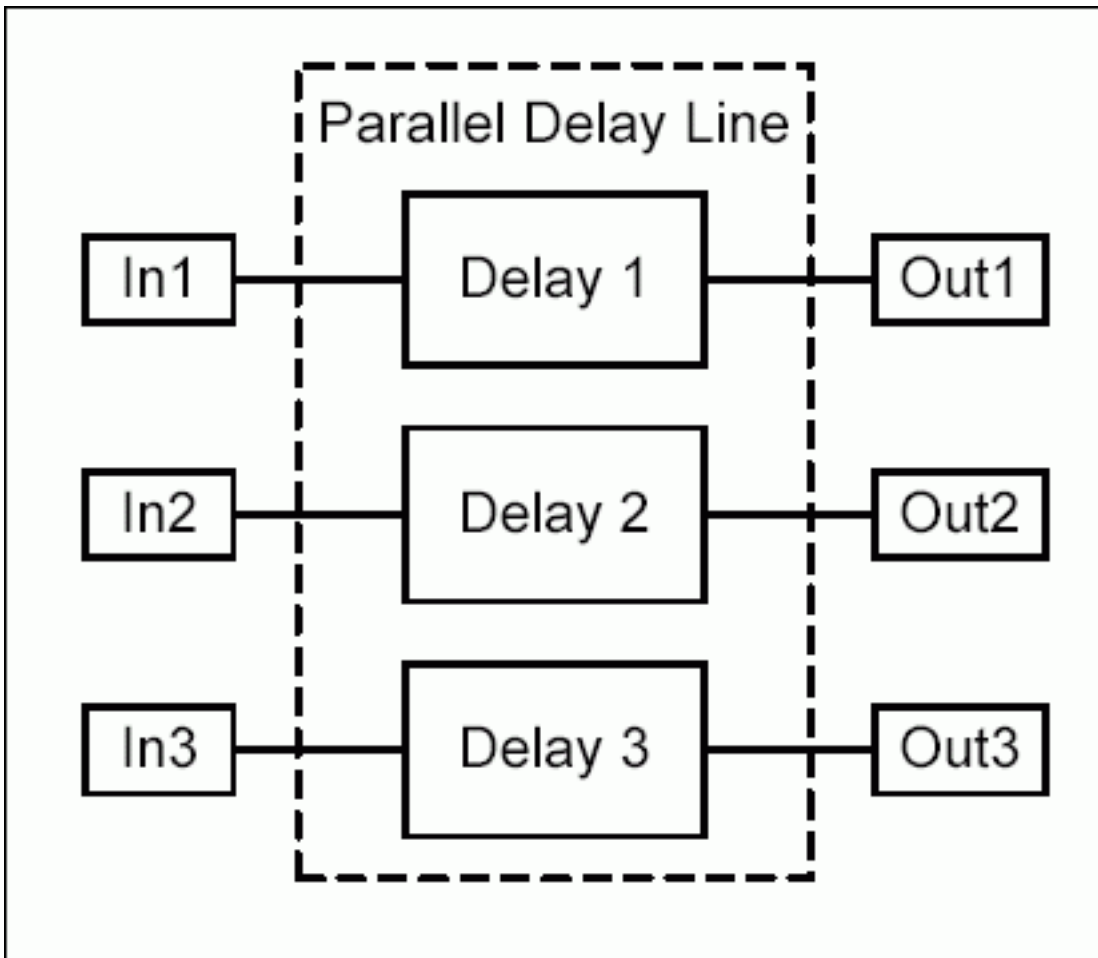

Figure 2. Non-programmable 3-in-1 parallel delay line functional diagram.

DS1013/DS1135/DS1135L

The DS1013, DS1135, and DS1135L are 3-in-1 silicon delay lines. The DS1135 is a 5.0V high-speed version and the recommended replacement for the DS1013 and DS1035. The DS1135L is the 3.3V version of the DS1135 and the recommended replacement for the DS1033. All these devices have leading and trailing edge accuracy. The DS1135/DS1135L have a better nominal delay tolerance than the DS1013. The nominal delay tolerance for the DS1013 is ± 2.0 ns and the nominal delay tolerance for the DS1135/DS1135L is ± 1.0 ns. The DS1013 has 17 versions (dash numbers) available with delays from 10ns to 200ns. The DS1135 has 8 versions with delays from 6ns to 30ns. The DS1135L has 6 versions with delays from 10ns to 30ns.

DS1033/DS1035

The DS1033 is a 3.3V device and the DS1035 is a 5.0V device. Both devices have 3 independent delays with leading- and trailing-edge accuracy. The nominal delay tolerance is ± 1.5 ns. The DS1033 has 7 versions with delays from 8ns to 30ns. The DS1035 has 8 versions with delays ranging from 6ns to 30ns. The DS1135 is the recommended replacement for the DS1035 and the DS1135L is the recommended replacement for the DS1033.

DS1044

The DS1044 has the same tolerance as the DS1035 but it has 4 delays instead of 3 delays. Also, the available delays are slightly different. The DS1044 has 10 versions available with delays from 5ns to 25ns. The nominal delay tolerance is ± 1.5 ns.

DS1007

The DS1007 has 7 delays. The first 4 delays (1 to 4) can be set between 3ns and 10ns and have leading edge accuracy only. The last 3 delays (5 to 7) can be set between 9ns and 40ns and have leading and trailing edge accuracy. The nominal delay tolerance is ± 2.0 ns.

Table 2. Non-programmable parallel delay lines comparison

	DS1013	DS1033	DS1035	DS1135	DS1135L	DS1044	DS1007
V _{CC}	5V	3.3V	5V	5V	3.3V	5V	5V
Package	14 pin DIP, 16 pin SO, 8 pin DIP	8 pin DIP, 8 pin SO	8 pin DIP, 8 pin SO	8 pin DIP, 8 pin SO, 8 pin μ SOP	8 pin SO, 8 pin μ SOP	14 pin DIP, 14 pin SO	16 pin DIP, 16 pin SO
Number of Independent Delays	3	3	3	3	3	4	7
Total Delays Available (ns)	10 to 200	8 to 30	6 to 30	6 to 30	10 to 30	5 to 25	3 to 10, 9 to 40
Nominal Tolerance	± 2.0 ns	± 1.5 ns	± 1.5 ns	± 1.0 ns	± 1.0 ns	± 1.5 ns	± 2.0 ns

Note: Device specifications have been provided here for device comparison. In the case of discrepancy between this application note and the data sheet, the data sheet supersedes this application note.

Tapped Delay Lines

The devices listed below are tapped delay lines with leading and trailing edge accuracy. Tapped delay lines have multiple delay cells in series. A tapped delay is useful when an application requires a delay line with one input and multiple delayed outputs such as for multiphased clocks. See **Figure 3** for a tapped delay line functional diagram.

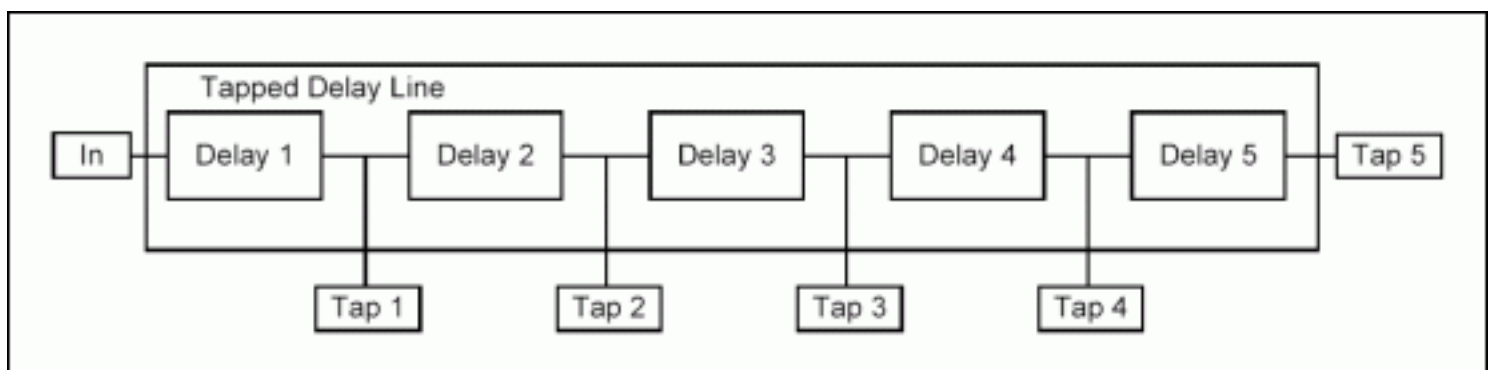

Figure 3. Non-programmable 5-tap delay line functional diagram.

DS1000

The DS1000 is obsolete but has been replaced with the pin-to-pin compatible DS1100. See the DS1100/DS1110L section below.

DS1004

The DS1004 is a 5-tap delay line. Delays range from 5ns to 25ns. The step size varies from 2ns to 5ns depending on the version of the device. The input-to-tap nominal delay tolerance is ± 1.5 ns. The DS1004 also has a tap-to-tap nominal tolerance of ± 0.75 ns.

DS1005

The DS1005 is also a 5-tap delay line but with larger delays and step sizes than the DS1004. Delays range from 12ns to 250ns. The step size varies from 12ns to 50ns depending on the version of the device. The input-to-tap nominal delay tolerance is ± 2 ns.

DS1100/DS1100L

The DS1100 and DS1100L are 5-tap delay lines. The DS1100 and DS1100L are improved, drop-in replacements for the DS1000 in 5V and 3.3V versions, respectively. Delays range from 4ns to 500ns. The step size varies from 4ns to 100ns depending on the version of the device. The input-to-tap nominal delay tolerance is ± 2 ns.

DS1010

The DS1010 is a 10-tap delay line. Delays range from 5ns to 500ns. The step size varies from 5ns to 50ns depending on the version of the device. The input-to-tap nominal delay tolerance is ± 2 ns.

DS1110/DS1110L

The DS1110 and DS1110L are 10-tap delay lines. The DS1110 and DS1110L are improved, drop-in replacements for the DS1010 in 5V and 3.3V versions, respectively. Delays range from 5ns to 500ns for the DS1110 and the step size varies from 5ns to 50ns depending on the version of the device. Delays range from 10ns to 500ns for the DS1110L and the step size varies from 10ns to 50ns depending on the version of the device. The input-to-tap nominal delay tolerance is ± 2 ns for the DS1110/DS1110L.

Table 3. Non-programmable tapped delay lines comparison

	DS1004	DS1005	DS1100	DS1100L	DS1010	DS1110	DS1110L
V _{CC}	5V	5V	5V	3.3V	5V	5V	3.3V
Package	8 pin DIP, 8 pin SO	14 pin DIP, 16 pin SO, 8 pin DIP	8 pin DIP, 8 pin SO, 8 pin μ SOP	8 pin DIP, 8 pin SO, 8 pin μ SOP	14 pin DIP, 16 pin SO	14 pin DIP, 16 pin SO, 14 pin TSSOP	14 pin TSSOP
Number of Taps	5	5	5	5	10	10	10
Delat to First Tap (ns)	5	12 to 50	4 to 60	4 to 60	5 to 100	5 to 50	5 to 50
Tap Increment (Step size) (ns)	2, 3, 4, or 5	12 to 50	4 to 100	4 to 100	5 to 100	5 to 50	5 to 50
Total Delays Available (ns)	5 to 25	12 to 250	4 to 500	4 to 500	5 to 500	5 to 500	5 to 500
Nominal Tolerance	± 1.5 ns	± 2 ns	± 5 ns	± 5 ns	± 5 ns	± 5 ns	± 5 ns

Note: Device specifications have been provided here for device comparison. In the case of discrepancy between this application note and the data sheet, the data sheet supersedes this application note.

Conclusion

This application note compares Maxim's delay lines to assist customers in choosing the appropriate device for their application. This comparison will prevent customers from sifting through multiple data sheets and the on-line parameter database. For further information contact Applications Support at MixedSignal.Apps@dalsemi.com.

Application Notes for delay lines can be found at http://www.maxim-ic.com/appnotes10.cfm/ac_pk/10.

Ordering Information

Application Note 229: <http://www.maxim-ic.com/an229>

More Information

For technical questions and support: <http://www.maxim-ic.com/support>

For samples: <http://www.maxim-ic.com/samples>

Other questions and comments: <http://www.maxim-ic.com/contact>

Related Parts

DS1004: [QuickView](#) -- [Full \(PDF\) Data Sheet](#) -- [Free Samples](#)

DS1005: [QuickView](#) -- [Full \(PDF\) Data Sheet](#) -- [Free Samples](#)

DS1007: [QuickView](#) -- [Full \(PDF\) Data Sheet](#) -- [Free Samples](#)

DS1010: [QuickView](#) -- [Full \(PDF\) Data Sheet](#) -- [Free Samples](#)

DS1013: [QuickView](#) -- [Full \(PDF\) Data Sheet](#) -- [Free Samples](#)

DS1020: [QuickView](#) -- [Full \(PDF\) Data Sheet](#) -- [Free Samples](#)

DS1021: [QuickView](#) -- [Full \(PDF\) Data Sheet](#)

DS1023: [QuickView](#) -- [Full \(PDF\) Data Sheet](#)

DS1033: [QuickView](#) -- [Full \(PDF\) Data Sheet](#) -- [Free Samples](#)
DS1035: [QuickView](#) -- [Full \(PDF\) Data Sheet](#)
DS1040: [QuickView](#) -- [Full \(PDF\) Data Sheet](#) -- [Free Samples](#)
DS1044: [QuickView](#) -- [Full \(PDF\) Data Sheet](#)
DS1045: [QuickView](#) -- [Full \(PDF\) Data Sheet](#) -- [Free Samples](#)
DS1100: [QuickView](#) -- [Full \(PDF\) Data Sheet](#) -- [Free Samples](#)
DS1100L: [QuickView](#) -- [Full \(PDF\) Data Sheet](#) -- [Free Samples](#)
DS1135: [QuickView](#) -- [Full \(PDF\) Data Sheet](#) -- [Free Samples](#)
DS1135L: [QuickView](#) -- [Full \(PDF\) Data Sheet](#) -- [Free Samples](#)

AN229, AN 229, APP229, Appnote229, Appnote 229

Copyright © by Maxim Integrated Products

Additional legal notices: <http://www.maxim-ic.com/legal>